

THE MANGA GUIDE™ TO

COMICS
INSIDE!

REGRESSION ANALYSIS

SHIN TAKAHASHI
IROHA INOUE
TREND-PRO CO., LTD.

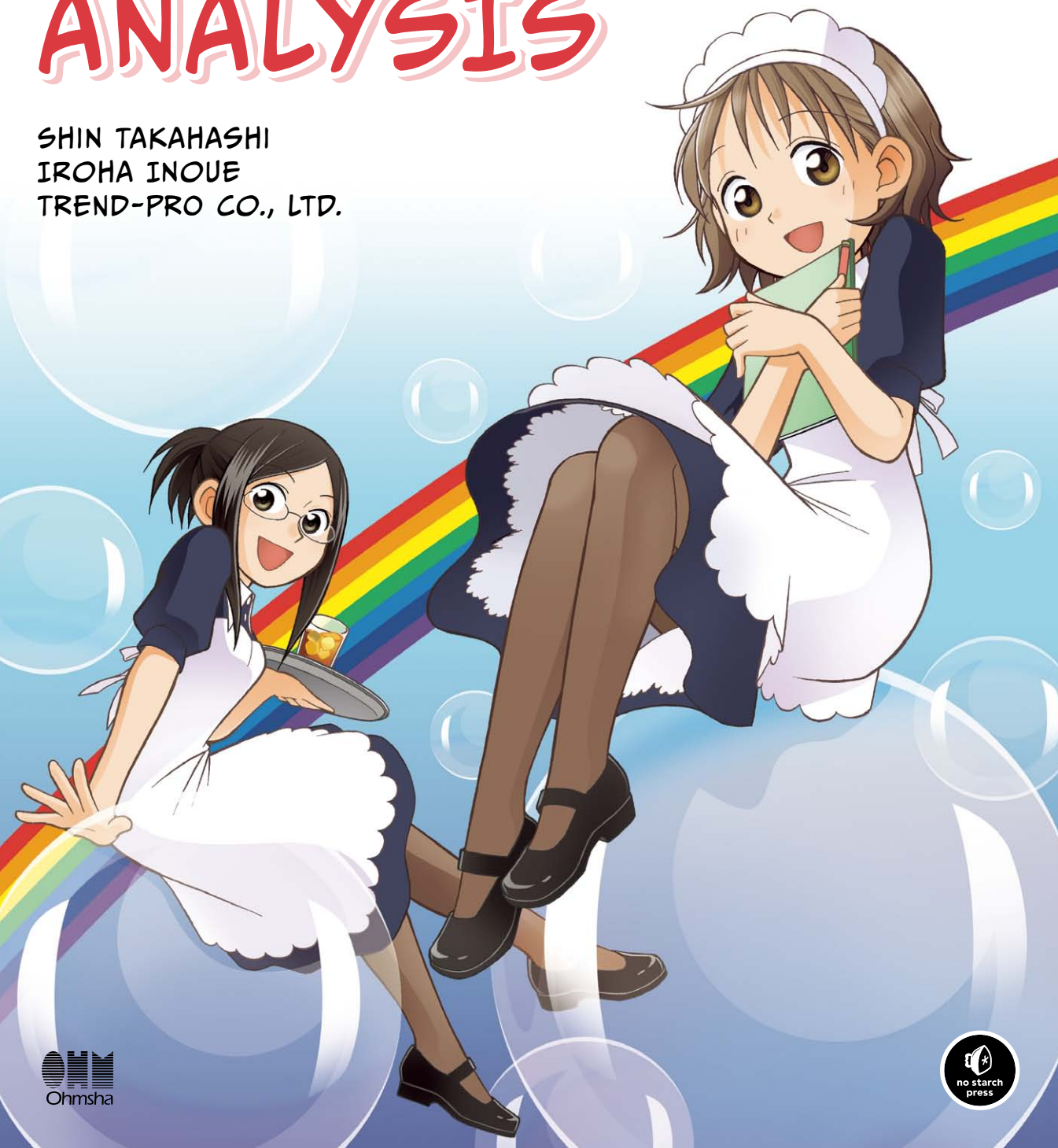

PRAISE FOR THE MANGA GUIDE SERIES

“Highly recommended.”

—CHOICE MAGAZINE ON *THE MANGA GUIDE TO DATABASES*

“Stimulus for the next generation of scientists.”

—SCIENTIFIC COMPUTING ON *THE MANGA GUIDE TO MOLECULAR BIOLOGY*

“A great fit of form and subject. Recommended.”

—OTAKU USA MAGAZINE ON *THE MANGA GUIDE TO PHYSICS*

“The art is charming and the humor engaging. A fun and fairly painless lesson on what many consider to be a less-than-thrilling subject.”

—SCHOOL LIBRARY JOURNAL ON *THE MANGA GUIDE TO STATISTICS*

“This is really what a good math text should be like. Unlike the majority of books on subjects like statistics, it doesn’t just present the material as a dry series of pointless-seeming formulas. It presents statistics as something *fun*, and something enlightening.”

—GOOD MATH, BAD MATH ON *THE MANGA GUIDE TO STATISTICS*

“I found the cartoon approach of this book so compelling and its story so endearing that I recommend that every teacher of introductory physics, in both high school and college, consider using it.”

—AMERICAN JOURNAL OF PHYSICS ON *THE MANGA GUIDE TO PHYSICS*

“The series is consistently good. A great way to introduce kids to the wonder and vastness of the cosmos.”

—DISCOVERY.COM ON *THE MANGA GUIDE TO THE UNIVERSE*

“A single tortured cry will escape the lips of every thirty-something biochem major who sees *The Manga Guide to Molecular Biology*: ‘Why, oh why couldn’t this have been written when I was in college?’”

—THE SAN FRANCISCO EXAMINER

“Scientifically solid . . . entertainingly bizarre.”

—CHAD ORZEL, AUTHOR OF *HOW TO TEACH PHYSICS TO YOUR DOG*,
ON *THE MANGA GUIDE TO RELATIVITY*

“A lot of fun to read. The interactions between the characters are lighthearted, and the whole setting has a sort of quirkiness about it that makes you keep reading just for the joy of it.”

—HACK A DAY ON *THE MANGA GUIDE TO ELECTRICITY*



"*The Manga Guide to Databases* was the most enjoyable tech book I've ever read."

—RIKKI KITE, LINUX PRO MAGAZINE

"The *Manga Guides* definitely have a place on my bookshelf."

—SMITHSONIAN'S "SURPRISING SCIENCE"

"For parents trying to give their kids an edge or just for kids with a curiosity about their electronics, *The Manga Guide to Electricity* should definitely be on their bookshelves."

—SACRAMENTO BOOK REVIEW

"This is a solid book and I wish there were more like it in the IT world."

—SLASHDOT ON *THE MANGA GUIDE TO DATABASES*

"*The Manga Guide to Electricity* makes accessible a very intimidating subject, letting the reader have fun while still delivering the goods."

—GEEKDAD BLOG, WIRED.COM

"If you want to introduce a subject that kids wouldn't normally be very interested in, give it an amusing storyline and wrap it in cartoons."

—MAKE ON *THE MANGA GUIDE TO STATISTICS*

"A clever blend that makes relativity easier to think about—even if you're no Einstein."

—STARDATE, UNIVERSITY OF TEXAS, ON *THE MANGA GUIDE TO RELATIVITY*

"This book does exactly what it is supposed to: offer a fun, interesting way to learn calculus concepts that would otherwise be extremely bland to memorize."

—DAILY TECH ON *THE MANGA GUIDE TO CALCULUS*

"The art is fantastic, and the teaching method is both fun and educational."

—ACTIVE ANIME ON *THE MANGA GUIDE TO PHYSICS*

"An awfully fun, highly educational read."

—FRAZZLEDDAD ON *THE MANGA GUIDE TO PHYSICS*

"Makes it possible for a 10-year-old to develop a decent working knowledge of a subject that sends most college students running for the hills."

—SKEPTICBLOG ON *THE MANGA GUIDE TO MOLECULAR BIOLOGY*

"This book is by far the best book I have read on the subject. I think this book absolutely rocks and recommend it to anyone working with or just interested in databases."

—GEEK AT LARGE ON *THE MANGA GUIDE TO DATABASES*

"The book purposefully departs from a traditional physics textbook and it does it very well."

—DR. MARINA MILNER-BOLOTIN, RYERSON UNIVERSITY ON *THE MANGA GUIDE TO PHYSICS*

"Kids would be, I think, much more likely to actually pick this up and find out if they are interested in statistics as opposed to a regular textbook."

—GEEK BOOK ON *THE MANGA GUIDE TO STATISTICS*

THE MANGA GUIDE™ TO REGRESSION ANALYSIS

CROISSANT

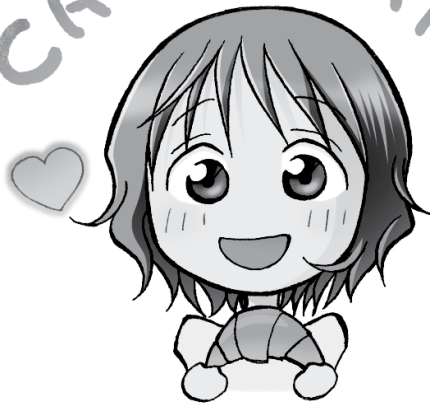

THE MANGA GUIDE™ TO
**REGRESSION
ANALYSIS**

SHIN TAKAHASHI,
IROHA INOUE, AND
TREND-PRO CO., LTD.



THE MANGA GUIDE TO REGRESSION ANALYSIS.

Copyright © 2016 by Shin Takahashi and TREND-PRO Co., Ltd.

The Manga Guide to Regression Analysis is a translation of the Japanese original, *Manga de wakaru tōkei-gaku kaiki bunseki-hen*, published by Ohmsha, Ltd. of Tokyo, Japan, © 2005 by Shin Takahashi and TREND-PRO Co., Ltd.

This English edition is co-published by No Starch Press, Inc. and Ohmsha, Ltd.

All rights reserved. No part of this work may be reproduced or transmitted in any form or by any means, electronic or mechanical, including photocopying, recording, or by any information storage or retrieval system, without the prior written permission of the copyright owner and the publisher.

First printing

20 19 18 17 16 1 2 3 4 5 6 7 8 9

ISBN-10: 1-59327-728-8

ISBN-13: 978-1-59327-728-4

Publisher: William Pollock

Author: Shin Takahashi

Illustrator: Iroha Inoue

Producer: TREND-PRO Co., Ltd.

Production Editor: Serena Yang

Developmental Editors: Liz Chadwick and Tyler Ortman

Technical Reviewers: James Church, Dan Furnas, and Alex Reinhart

Compositor: Susan Glinert Stevens

Copyeditor: Paula L. Fleming

Proofreader: Alison Law

Indexer: BIM Creatives, LLC.

For information on distribution, translations, or bulk sales, please contact No Starch Press, Inc. directly:
No Starch Press, Inc.

245 8th Street, San Francisco, CA 94103

phone: 415.863.9900; info@nostarch.com; <http://www.nostarch.com/>

Library of Congress Cataloging-in-Publication Data

Names: Takahashi, Shin. | Inoue, Iroha. | Trend-pro Co.

Title: The manga guide to regression analysis / by Shin Takahashi, Iroha Inoue, and Trend-Pro Co., Ltd.

Other titles: Manga de wakaru tōkeigaku. Kaiki bunsekihen. English

Description: San Francisco : No Starch Press, [2016] | Includes index.

Identifiers: LCCN 2016000594 (print) | LCCN 2016003356 (ebook) | ISBN 9781593277284 | ISBN 1593277288 | ISBN 9781593277529 (epub) | ISBN 9781593277536 (mobi)

Subjects: LCSH: Regression analysis. | Graphic novels.

Classification: LCC QA278.2 .T34713 2016 (print) | LCC QA278.2 (ebook) | DDC 519.5/36--dc23

LC record available at <http://lccn.loc.gov/2016000594>

No Starch Press and the No Starch Press logo are registered trademarks of No Starch Press, Inc. Other product and company names mentioned herein may be the trademarks of their respective owners. Rather than use a trademark symbol with every occurrence of a trademarked name, we are using the names only in an editorial fashion and to the benefit of the trademark owner, with no intention of infringement of the trademark.

The information in this book is distributed on an “As Is” basis, without warranty. While every precaution has been taken in the preparation of this work, neither the author nor No Starch Press, Inc. shall have any liability to any person or entity with respect to any loss or damage caused or alleged to be caused directly or indirectly by the information contained in it.

All characters in this publication are fictitious, and any resemblance to real persons, living or dead, is purely coincidental.

CONTENTS

PREFACE	xi
---------------	----

PROLOGUE

MORE TEA?	1
-----------------	---

1

A REFRESHING GLASS OF MATH	11
----------------------------------	----

Building a Foundation	12
-----------------------------	----

Inverse Functions	14
-------------------------	----

Exponents and Logarithms	19
--------------------------------	----

Rules for Exponents and Logarithms	21
--	----

Differential Calculus	24
-----------------------------	----

Matrices	37
----------------	----

Adding Matrices	39
-----------------------	----

Multiplying Matrices	40
----------------------------	----

The Rules of Matrix Multiplication	43
--	----

Identity and Inverse Matrices	44
-------------------------------------	----

Statistical Data Types	46
------------------------------	----

Hypothesis Testing	48
--------------------------	----

Measuring Variation	49
---------------------------	----

Sum of Squared Deviations	50
---------------------------------	----

Variance	50
----------------	----

Standard Deviation	51
--------------------------	----

Probability Density Functions	52
-------------------------------------	----

Normal Distributions	53
----------------------------	----

Chi-Squared Distributions	54
---------------------------------	----

Probability Density Distribution Tables	55
---	----

F Distributions	57
-----------------------	----

2

SIMPLE REGRESSION ANALYSIS	61
----------------------------------	----

First Steps	62
-------------------	----

Plotting the Data	64
-------------------------	----

The Regression Equation	66
-------------------------------	----

General Regression Analysis Procedure	68
---	----

Step 1: Draw a scatter plot of the independent variable versus the dependent variable. If the dots line up, the variables may be correlated	69
---	----

Step 2: Calculate the regression equation	71
---	----

Step 3: Calculate the correlation coefficient (R) and assess our population and assumptions	78
--	----

Samples and Populations	82
-------------------------------	----

Assumptions of Normality	85
Step 4: Conduct the analysis of variance	87
Step 5: Calculate the confidence intervals	91
Step 6: Make a prediction!	95
Which Steps Are Necessary?	100
Standardized Residual	100
Interpolation and Extrapolation	102
Autocorrelation	102
Nonlinear Regression	103
Transforming Nonlinear Equations into Linear Equations	104

3

MULTIPLE REGRESSION ANALYSIS	107
Predicting with Many Variables	108
The Multiple Regression Equation	112
Multiple Regression Analysis Procedure	112
Step 1: Draw a scatter plot of each predictor variable and the outcome variable to see if they appear to be related	113
Step 2: Calculate the multiple regression equation	115
Step 3: Examine the accuracy of the multiple regression equation	119
The Trouble with R^2	122
Adjusted R^2	124
Hypothesis Testing with Multiple Regression	127
Step 4: Conduct the Analysis of Variance (ANOVA) Test	128
Finding S_{11} and S_{22}	132
Step 5: Calculate confidence intervals for the population	133
Step 6: Make a prediction!	136
Choosing the Best Combination of Predictor Variables	138
Assessing Populations with Multiple Regression Analysis	142
Standardized Residuals	143
Mahalanobis Distance	144
Step 1	144
Step 2	145
Step 3	146
Using Categorical Data in Multiple Regression Analysis	147
Multicollinearity	149
Determining the Relative Influence of Predictor Variables on the Outcome Variable	149

4

LOGISTIC REGRESSION ANALYSIS	153
The Final Lesson	154
The Maximum Likelihood Method	160
Finding the Maximum Likelihood Using the Likelihood Function	163
Choosing Predictor Variables	164

Logistic Regression Analysis in Action!	168
Logistic Regression Analysis Procedure	168
Step 1: Draw a scatter plot of the predictor variables and the outcome variable to see whether they appear to be related	169
Step 2: Calculate the logistic regression equation.	170
Step 3: Assess the accuracy of the equation	173
Step 4: Conduct the hypothesis tests.	178
Step 5: Predict whether the Norns Special will sell	182
Logistic Regression Analysis in the Real World	190
Logit, Odds Ratio, and Relative Risk	190
Logit.	190
Odds Ratio	191
Adjusted Odds Ratio	192
Hypothesis Testing with Odds	194
Confidence Interval for an Odds Ratio	194
Relative Risk	195
APPENDIX	
REGRESSION CALCULATIONS WITH EXCEL	197
Euler's Number	198
Powers	200
Natural Logarithms	200
Matrix Multiplication	201
Matrix Inversion.	202
Calculating a Chi-Squared Statistic from a p-Value	204
Calculating a p-Value from a Chi-Squared Statistic	205
Calculating an F Statistic from a p-Value	206
Calculating a p-Value from an F Statistic	208
Partial Regression Coefficient of a Multiple Regression Analysis	209
Regression Coefficient of a Logistic Regression Equation	210
INDEX	213

PREFACE

This book is an introduction to regression analysis, covering simple, multiple, and logistic regression analysis.

Simple and multiple regression analysis are statistical methods for predicting values; for example, you can use simple regression analysis to predict the number of iced tea orders based on the day's high temperature or use multiple regression analysis to predict monthly sales of a shop based on its size and distance from the nearest train station.

Logistic regression analysis is a method for predicting probability, such as the probability of selling a particular cake based on a certain day of the week.

The intended readers of this book are statistics and math students who've found it difficult to grasp regression analysis, or anyone wanting to get started with statistical predictions and probabilities. You'll need some basic statistical knowledge before you start. *The Manga Guide to Statistics* (No Starch Press, 2008) is an excellent primer to prepare you for the work in this book.

This book consists of four chapters:

- Chapter 1: A Refreshing Glass of Math
- Chapter 2: Simple Regression Analysis
- Chapter 3: Multiple Regression Analysis
- Chapter 4: Logistic Regression Analysis

Each chapter has a manga section and a slightly more technical text section. You can get a basic overview from the manga, and some more useful details and definitions from the text sections.

I'd like to mention a few words about Chapter 1. Although many readers may have already learned the topics in this chapter, like differentiation and matrix operations, Chapter 1 reviews these topics in context of regression analysis, which will be useful for the lessons that follow. If Chapter 1 is merely a refresher for you, that's great. If you've never studied those topics or it's been a long time since you have, it's worth putting in a bit of effort to make sure you understand Chapter 1 first.

In this book, the math for the calculations is covered in detail. If you're good at math, you should be able to follow along and make sense of the calculations. If you're not so good at math, you can just get an overview of the procedure and use the step-by-step instructions to find the actual answers. You don't need to force yourself to understand the math part right now. Keep yourself relaxed. However, do take a look at the procedure of the calculations.

We've rounded some of the figures in this book to make them easier to read, which means that some of the values may be inconsistent with the values you will get by calculating them yourself, though not by much. We ask for your understanding.

I would like to thank my publisher, Ohmsha, for giving me the opportunity to write this book. I would also like to thank TREND-PRO, Co., Ltd. for turning my manuscript into this manga, the scenario writer re_akino, and the illustrator Iroha Inoue. Last but not least, I would like to thank Dr. Sakaori Fumitake of College of Social Relations, Rikkyo University. He provided with me invaluable advice, much more than he had given me when I was preparing my previous book. I'd like to express my deep appreciation.

Shin Takahashi

September 2005

PROLOGUE
MORE TEA?

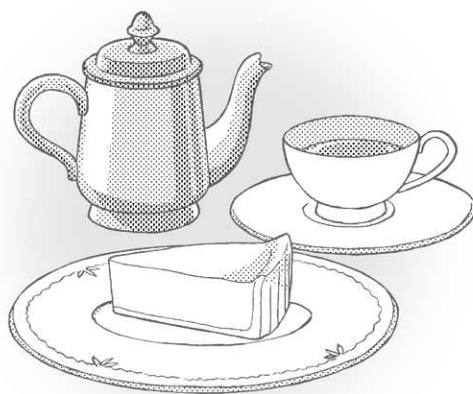

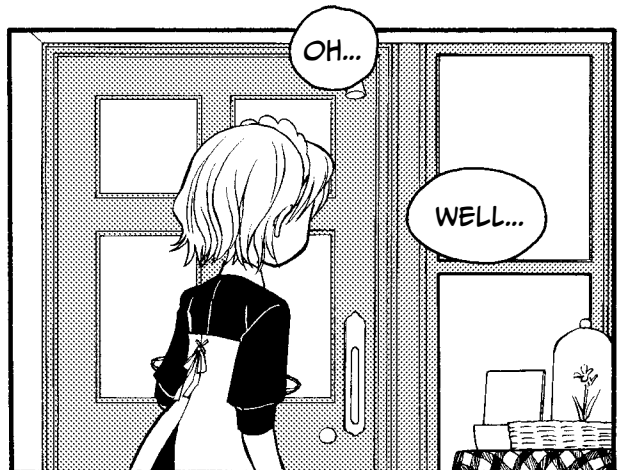
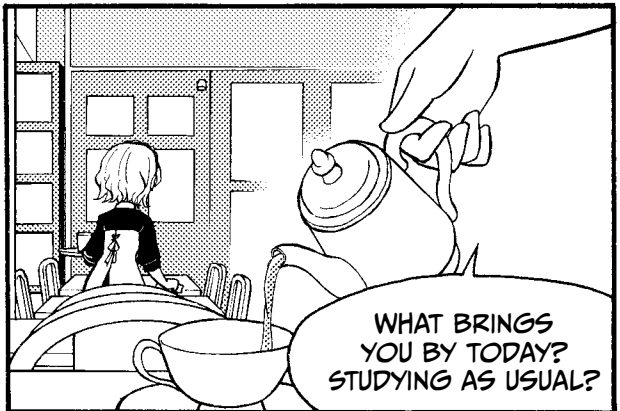

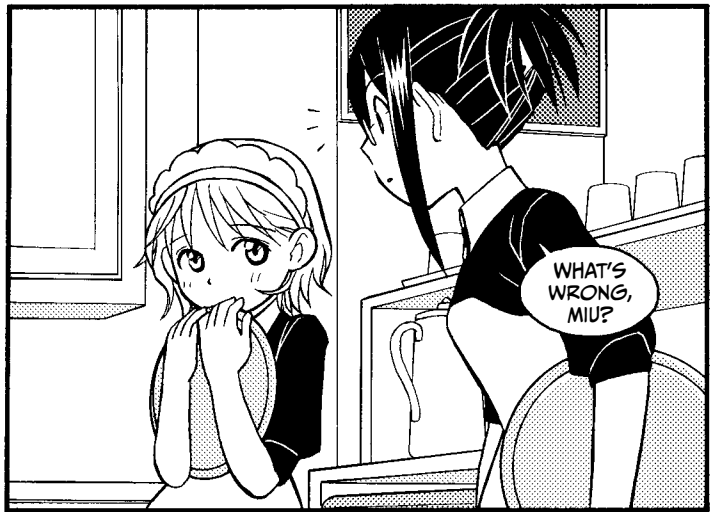
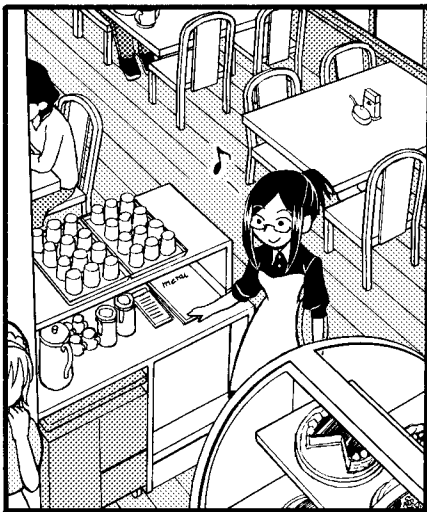
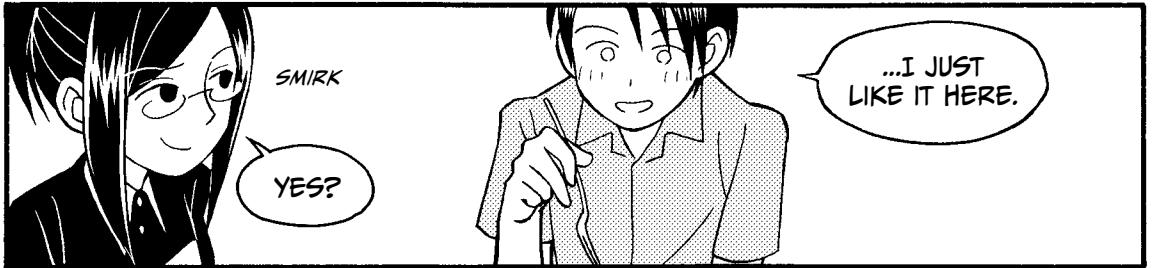
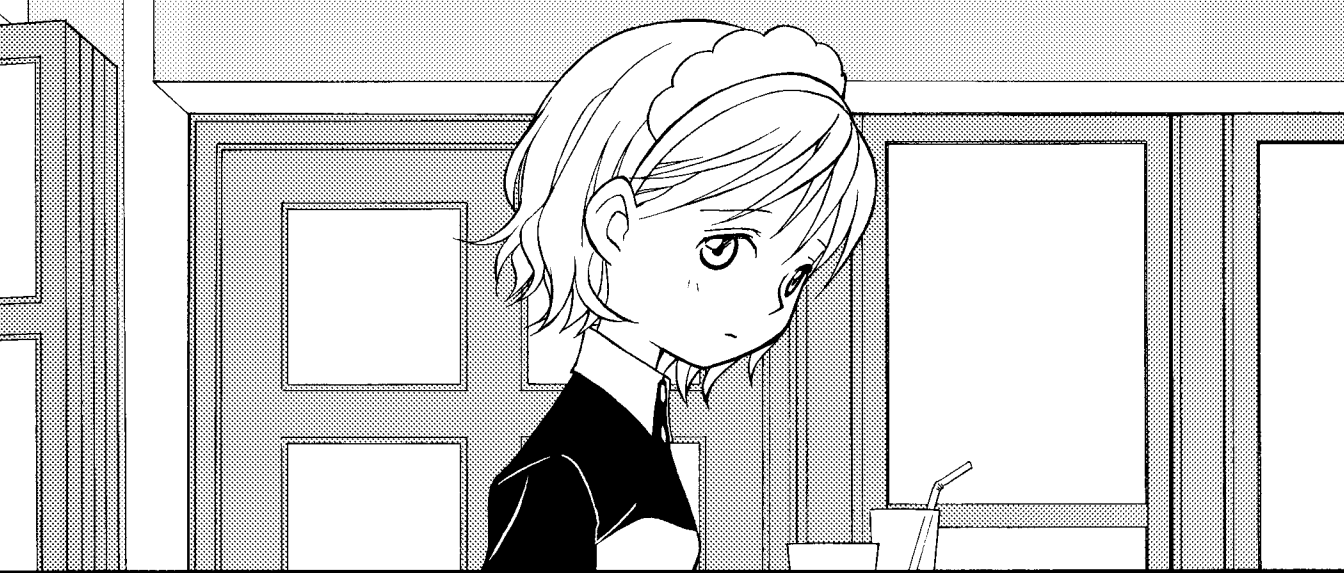

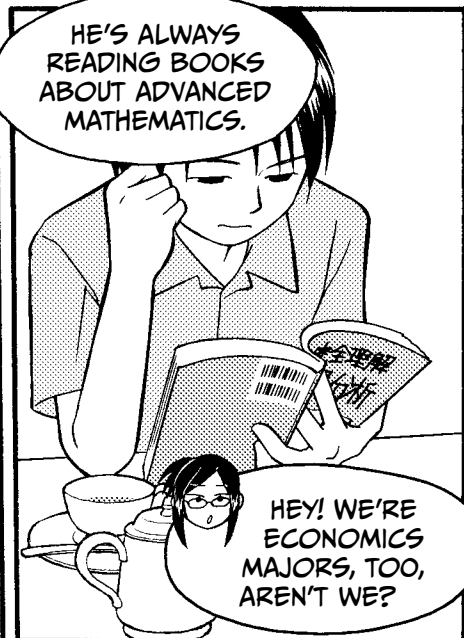
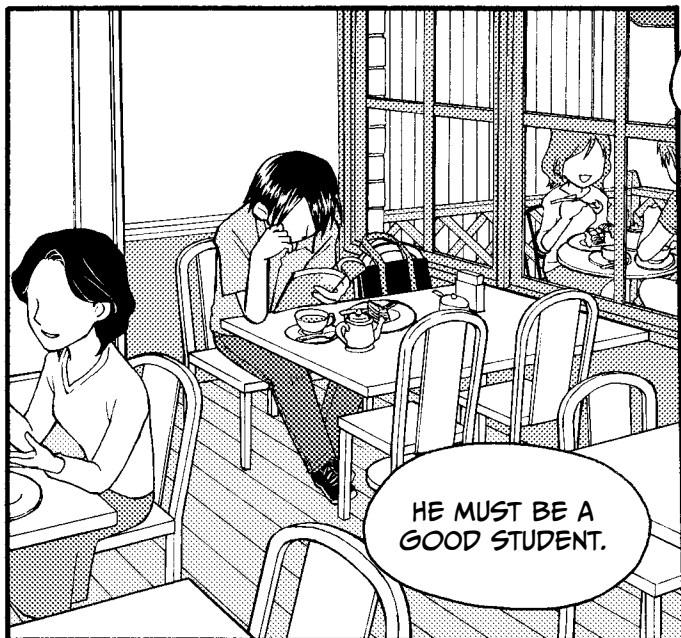
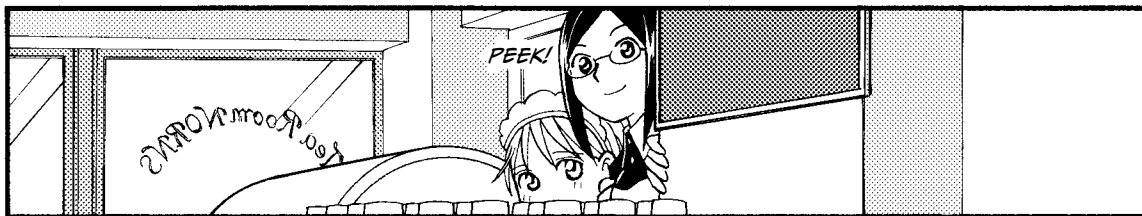
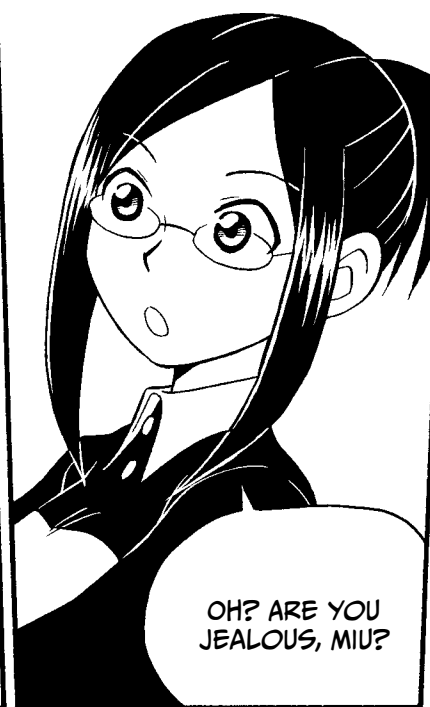
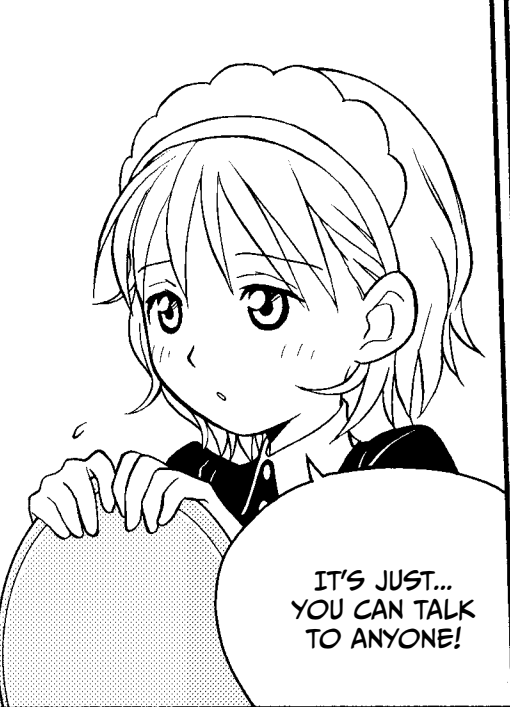

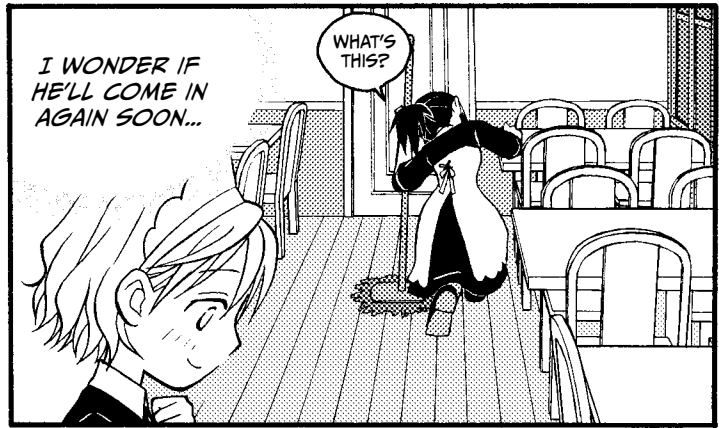
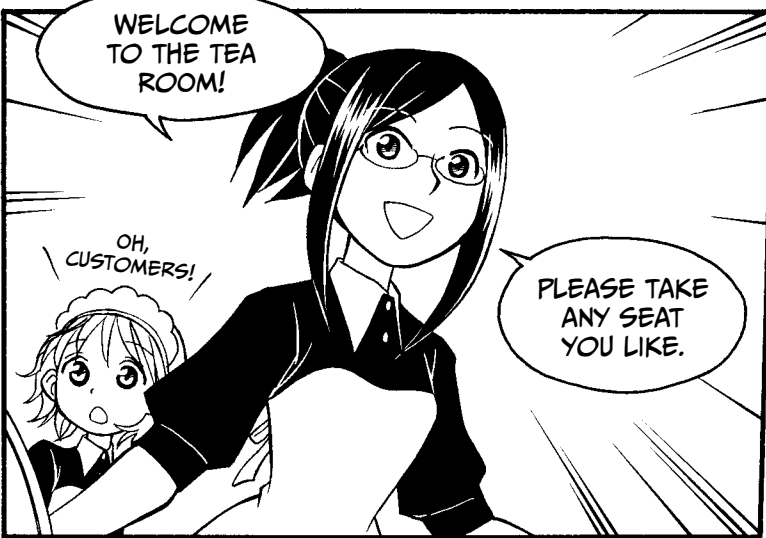
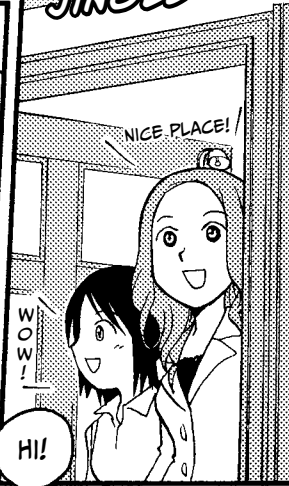
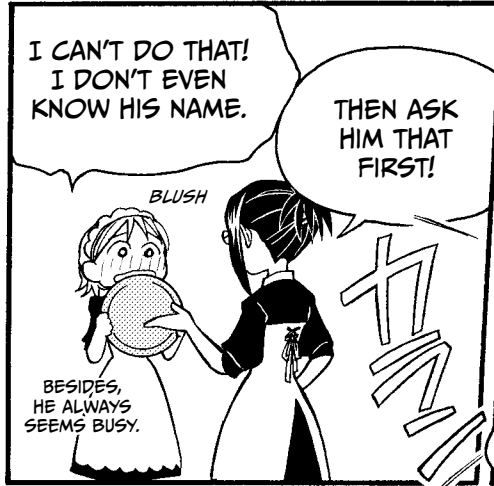
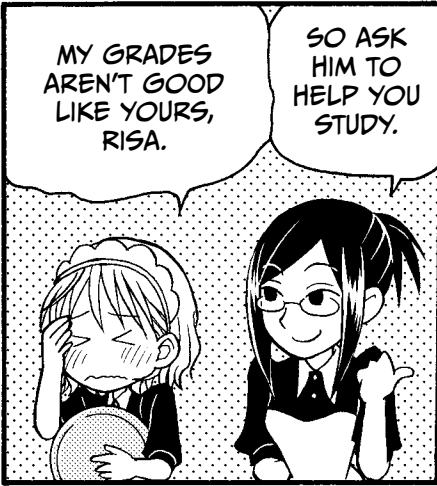

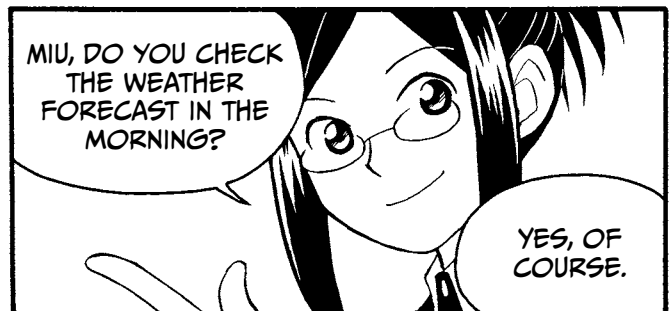
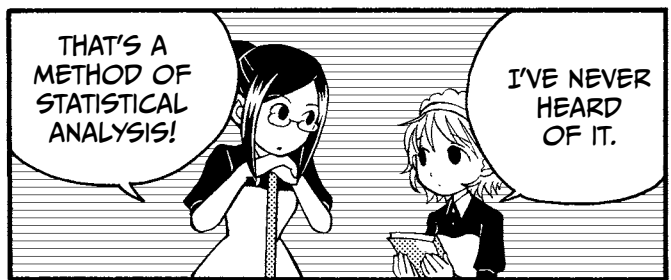
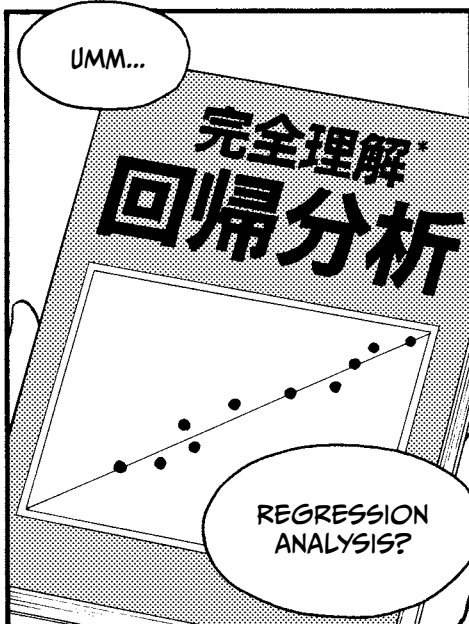
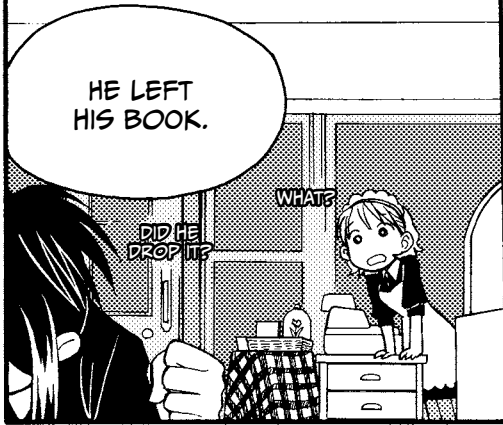

* INTRODUCTION TO REGRESSION ANALYSIS

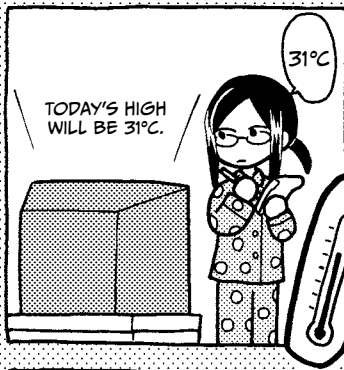

SUPPOSE WE WERE KEEPING A RECORD OF THE HIGH TEMPERATURE AND THE NUMBER OF ORDERS OF ICED TEA AT OUR SHOP EVERY DAY.

HIGH OF 31°C...

8/22	29	77
8/23	28	62
8/24	34	93
8/25	31	84
8/26	25	59
8/27	29	64
8/28	32	80
8/29	31	?

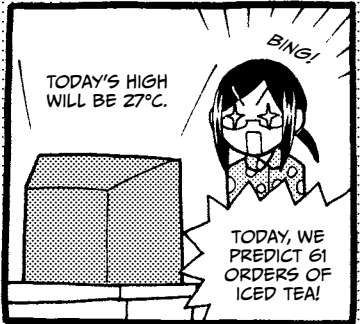

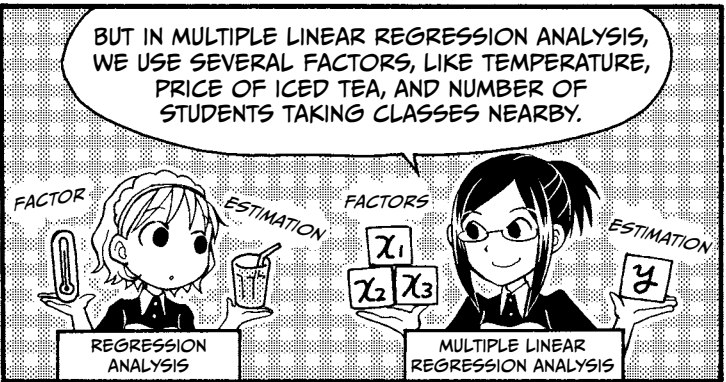
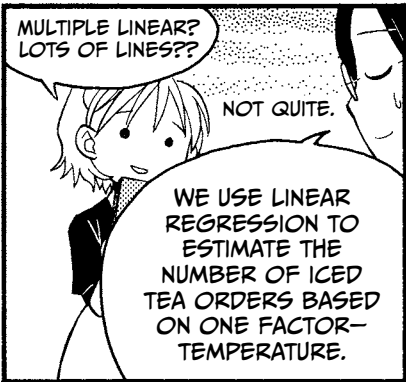
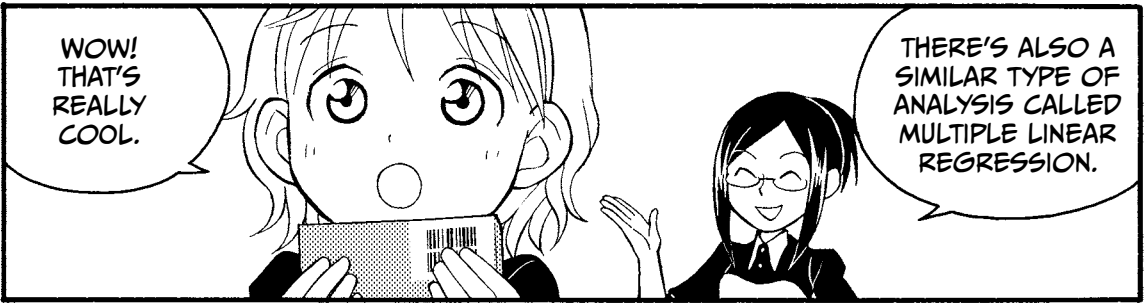

USING LINEAR REGRESSION ANALYSIS, YOU CAN ESTIMATE THE NUMBER OF ORDERS OF ICED TEA BASED ON THE HIGH TEMPERATURE!



LET'S LOOK AT AN EXAMPLE OF MULTIPLE LINEAR REGRESSION ANALYSIS.

MR. GUYMAN IS THE CEO OF A CHAIN STORE. IN ADDITION TO TRACKING SALES, HE ALSO KEEPS THE FOLLOWING RECORDS FOR EACH OF HIS STORES:

- DISTANCE TO THE NEAREST COMPETING STORE
- NUMBER OF HOUSES WITHIN A MILE OF THE STORE
- ADVERTISING EXPENDITURE

Store	Distance to nearest competing store (m)	Houses within a mile of the store	Advertising expenditure (yen)	Sales (yen)
A 	○○○	○○○	○○○	○○○
B 	△△△	△△△	△△△	△△△
C 	□□□	□□□	□□□	□□□
	⋮	⋮	⋮	⋮

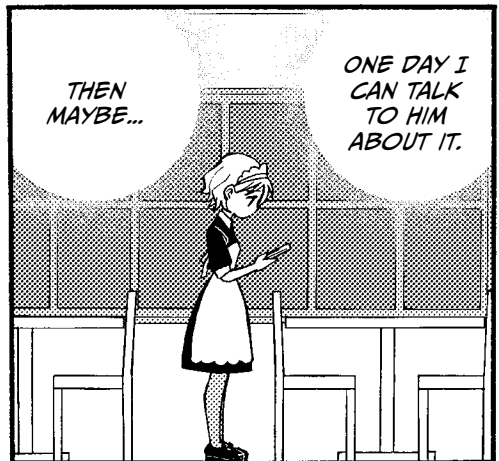
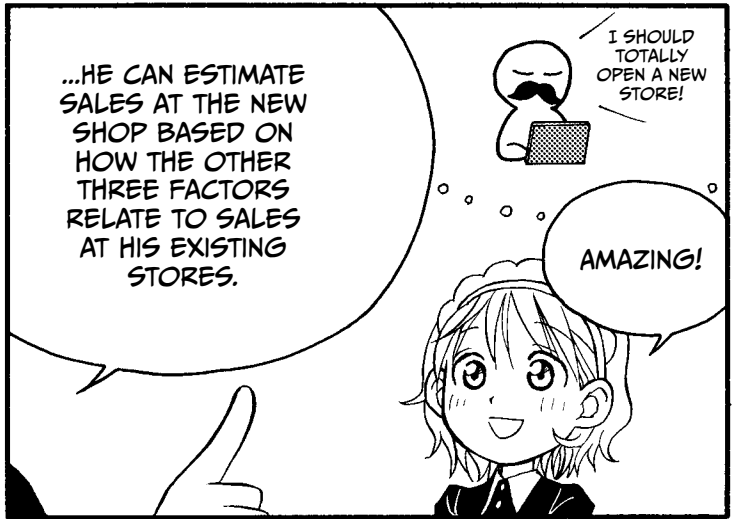

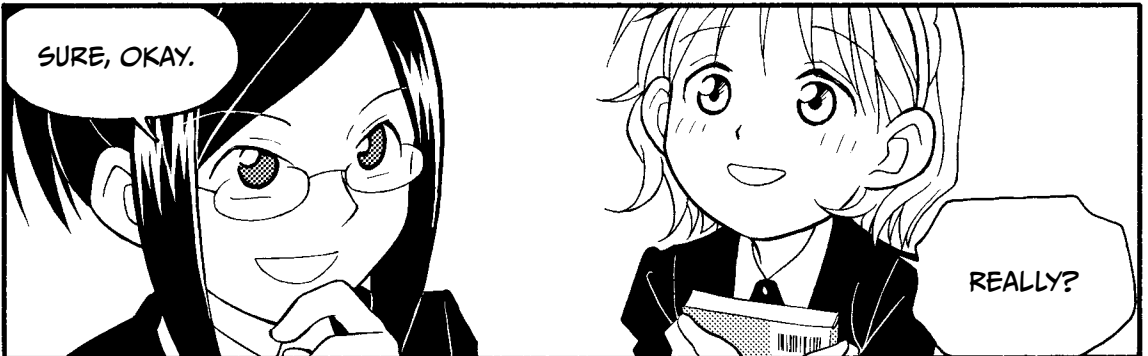
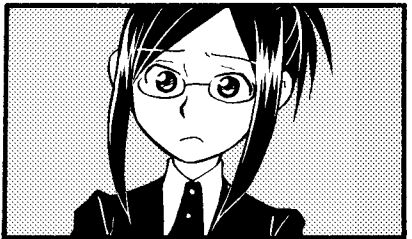
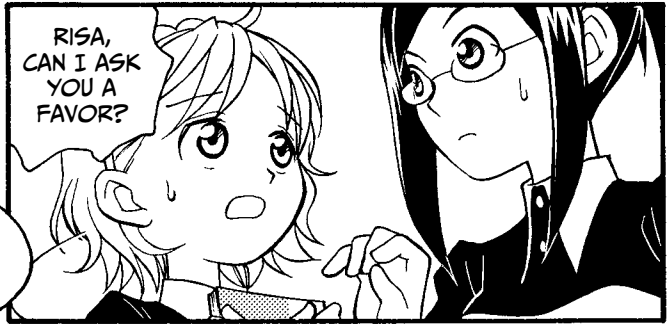

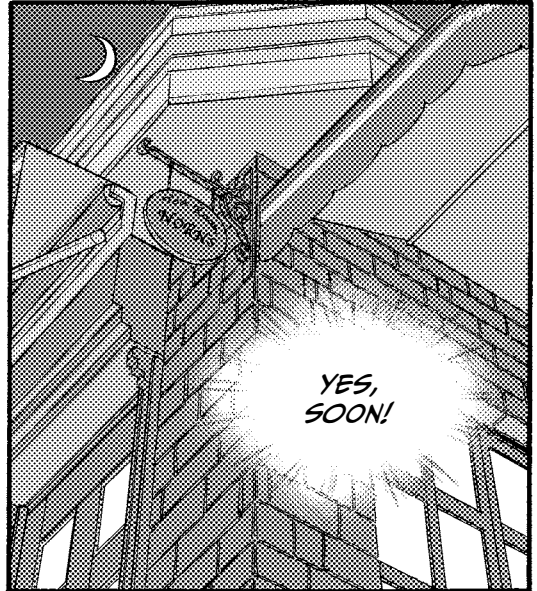
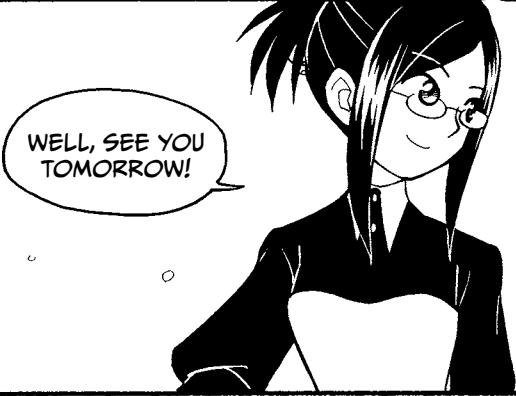
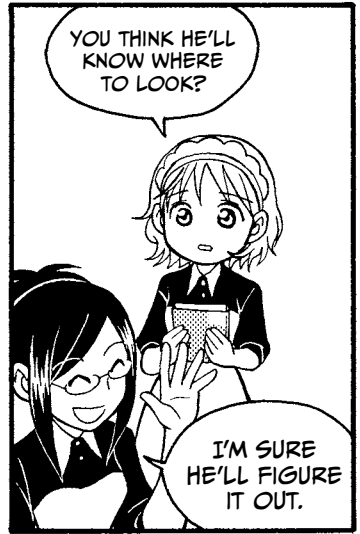
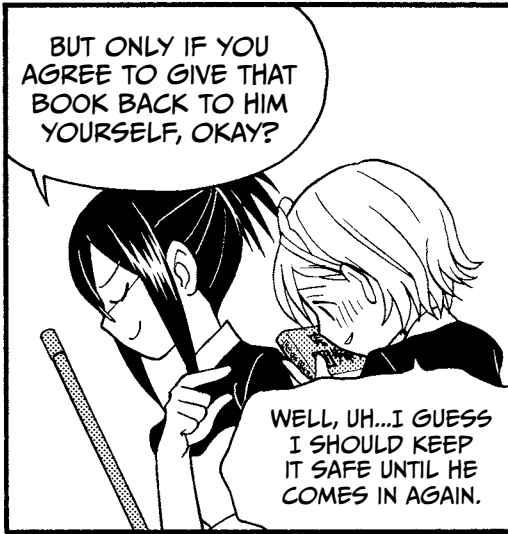

1

A REFRESHING
GLASS OF MATH

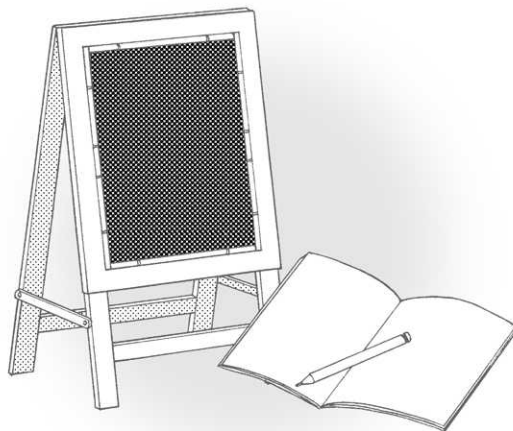

BUILDING A FOUNDATION



PHEW!

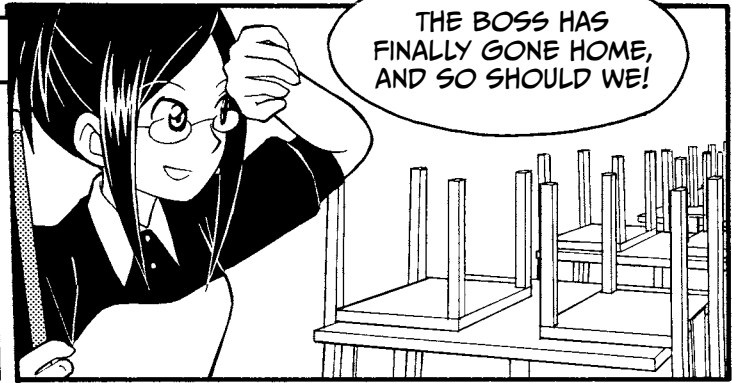

THE BOSS HAS FINALLY GONE HOME, AND SO SHOULD WE!

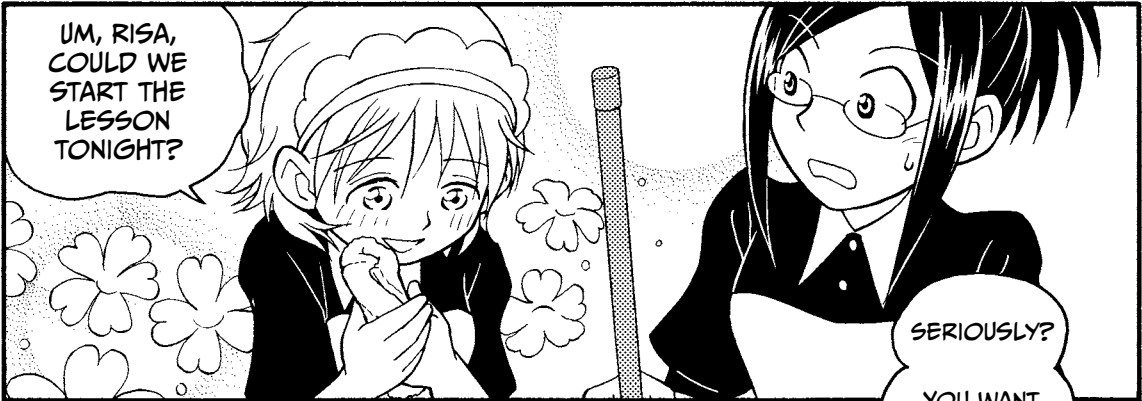

UM, RISA, COULD WE START THE LESSON TONIGHT?

SERIOUSLY?
YOU WANT TO START NOW?!

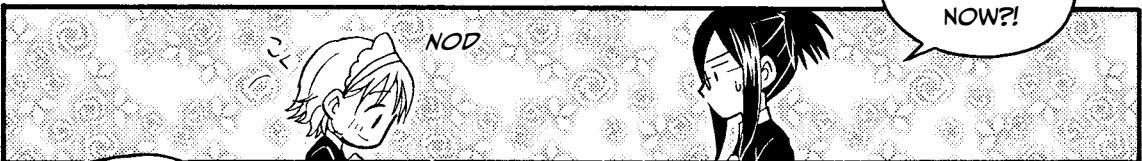

NOD



I'VE NEVER SEEN YOU SO EXCITED TO LEARN! USUALLY YOU NAP IN CLASS.

YEAH, IT'S JUST... I...

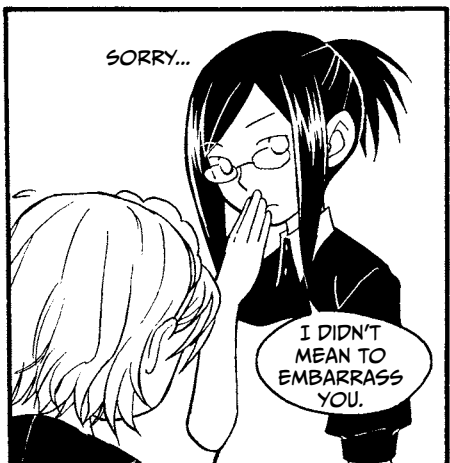

SORRY...

I DIDN'T MEAN TO EMBARRASS YOU.

INVERSE FUNCTIONS

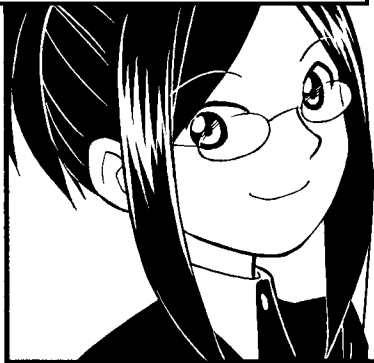

$$y = 2x + 1$$

FIRST, I'LL EXPLAIN INVERSE FUNCTIONS USING THE LINEAR FUNCTION $y = 2x + 1$ AS AN EXAMPLE.

WHEN x IS ZERO, WHAT IS THE VALUE OF y ?

$$\begin{aligned} y &= 2x + 1 \\ &= 2 \times 0 + 1 \\ &= 0 + 1 \\ &= 1 \end{aligned}$$

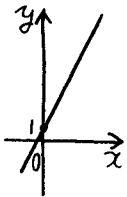

IT'S 1.

HOW ABOUT WHEN x IS 3?

$$\begin{aligned} y &= 2x + 1 \\ &= 2 \times 3 + 1 \\ &= 6 + 1 \\ &= 7 \end{aligned}$$

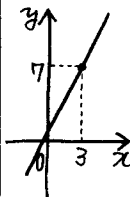

IT'S 7.

THE VALUE OF y *DEPENDS* ON THE VALUE OF x .

SO WE CALL y THE *OUTCOME*, OR *DEPENDENT VARIABLE*, AND x THE *PREDICTOR*, OR *INDEPENDENT VARIABLE*.

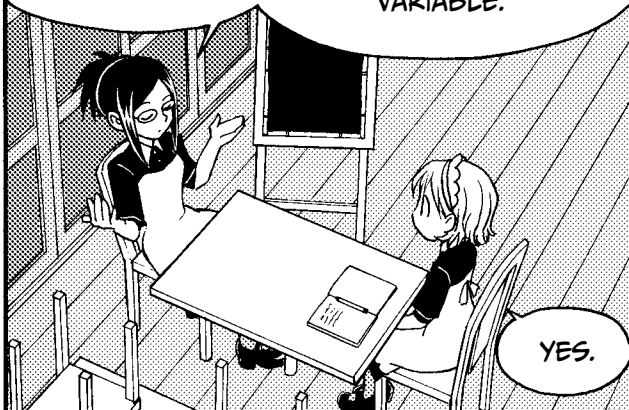

YOU COULD SAY THAT x IS THE BOSS OF y .

I'M THIRSTY!

YOUR DRINK, SIR.

WHAT'S 2 CUBED?

8.

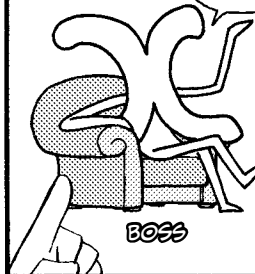

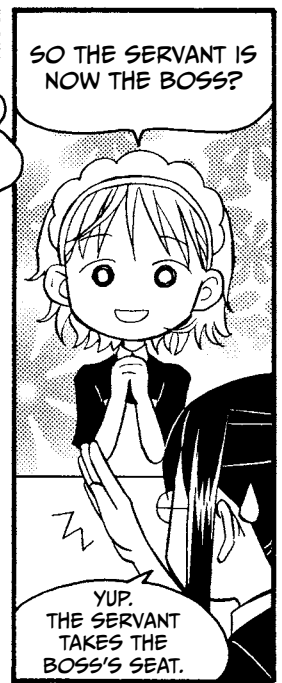
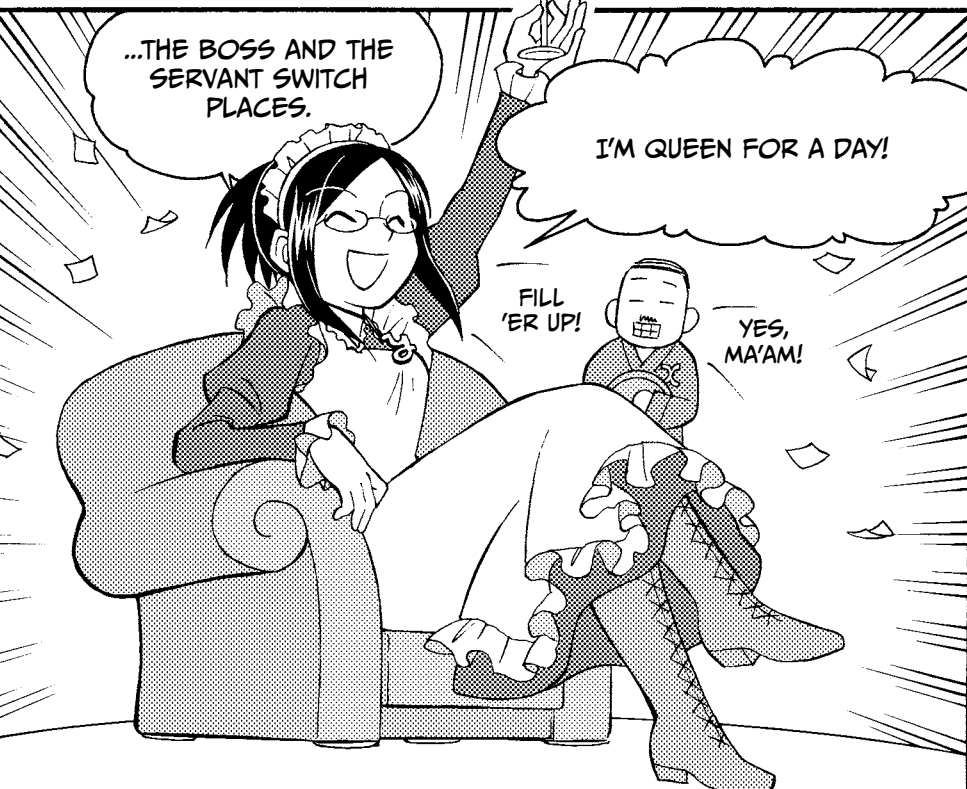
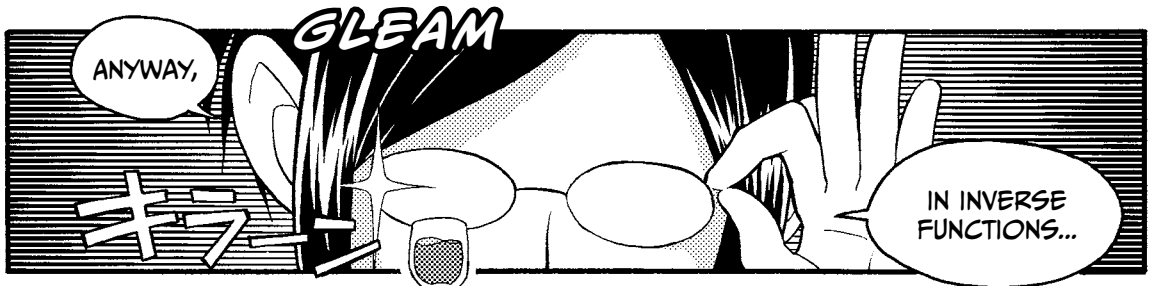
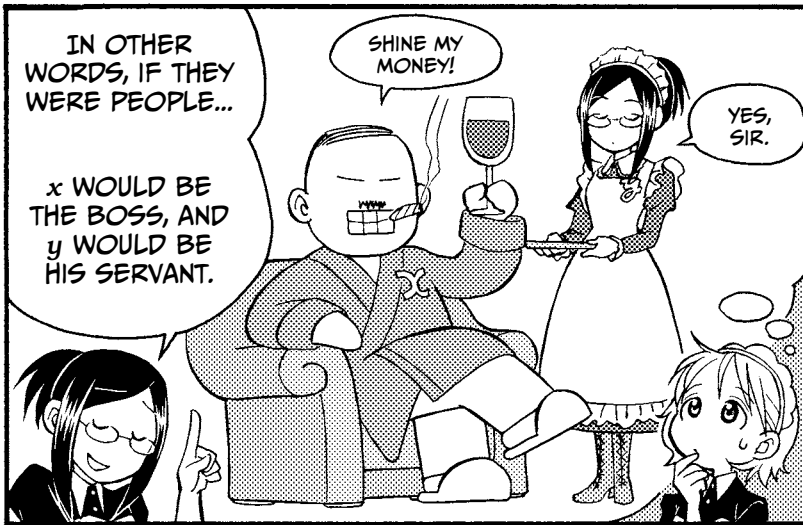

SO FOR THE EXAMPLE
 $y = 2x + 1$, THE INVERSE
FUNCTION IS...

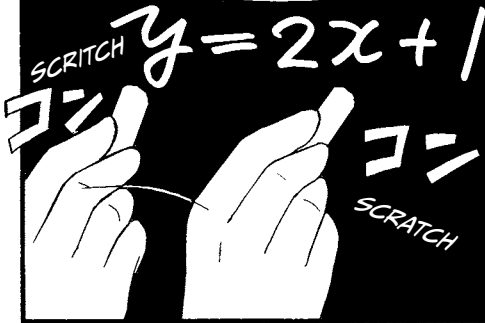

$$y = 2x + 1$$

↓ ↓

$$x = 2y + 1$$

...ONE IN WHICH
y AND x HAVE
SWITCHED SEATS.

HOWEVER,

WE WANT y ALL
BY ITSELF, SO...

$$x = 2y + 1$$

↓ TRANSPOSE

$$2y = x - 1$$

$$y = \frac{1}{2}x - \frac{1}{2}$$

WE
REORGANIZE
THE FUNCTION
LIKE THIS.

YOU TRANSPOSED
IT AND DIVIDED BY
2, SO NOW y IS
ALONE.

THAT'S RIGHT. TO
EXPLAIN WHY THIS IS
USEFUL, LET'S DRAW
A GRAPH.

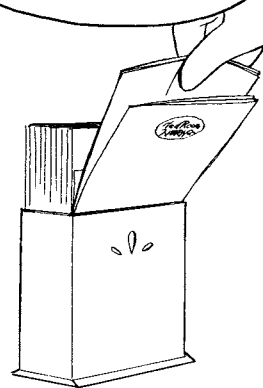

MIU, CAN YOU GRAB A MARKER?



$y = 2x + 1$
↓
 $x = 2y + 1$
↓ TRANSPOSE
 $2y = x - 1$
 $y = \frac{x - 1}{2}$

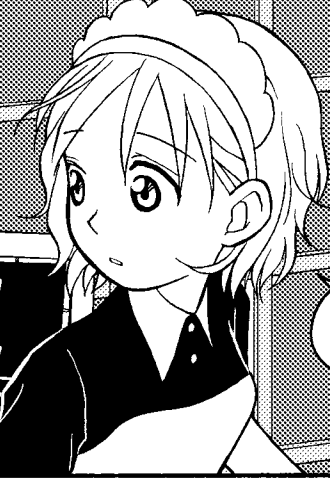

OKAY, HOLD ON.

DRAW A GRAPH FOR $y = 2x + 1$.



DRAWING NEATLY ON A NAPKIN IS HARD!

UM, LET'S SEE.

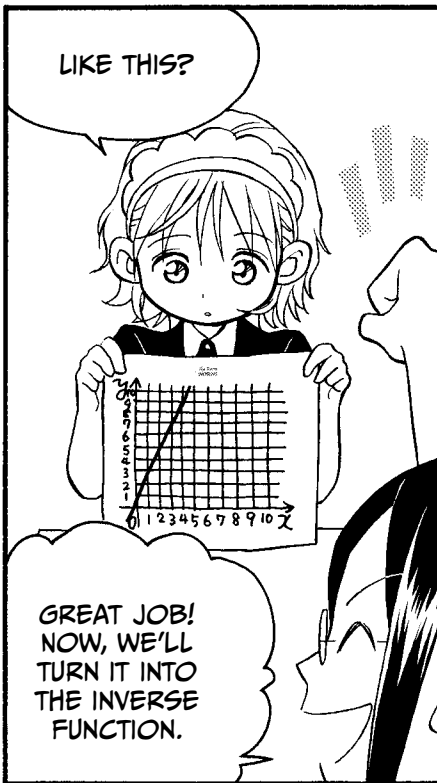

LIKE THIS?

GREAT JOB! NOW, WE'LL TURN IT INTO THE INVERSE FUNCTION.

WRITE y ON THE x AXIS AND x ON THE y AXIS.



DONE!

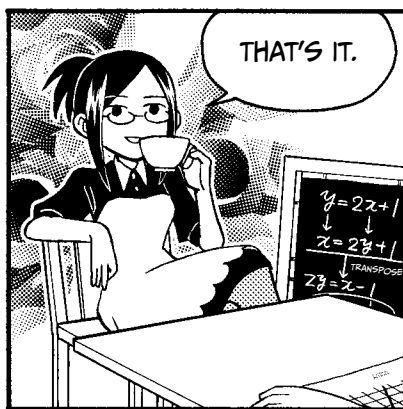
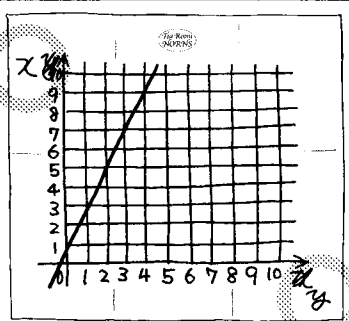

THAT'S IT.

$y = 2x + 1$
↓
 $x = 2y + 1$
↓ TRANSPOSE
 $2y = x - 1$

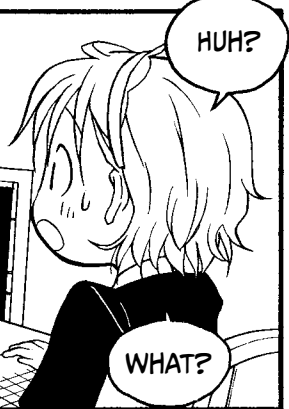

HUH?

WHAT?

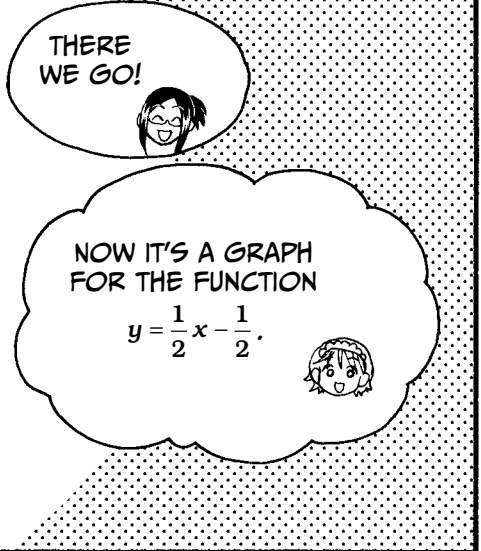
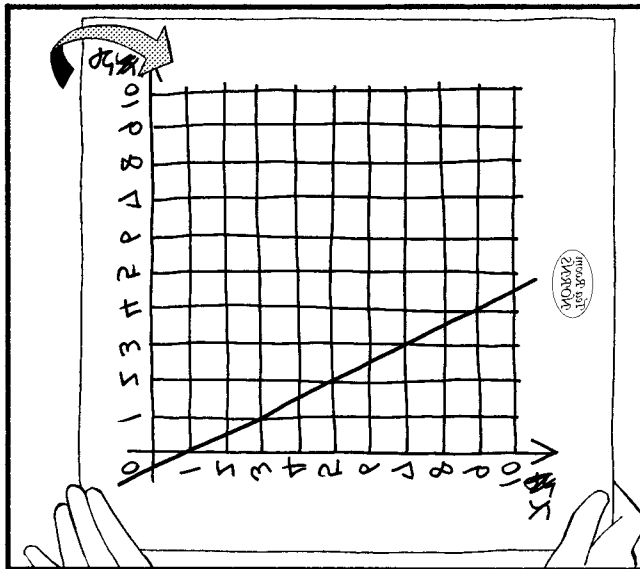
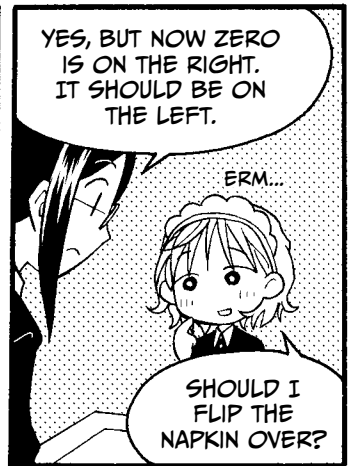
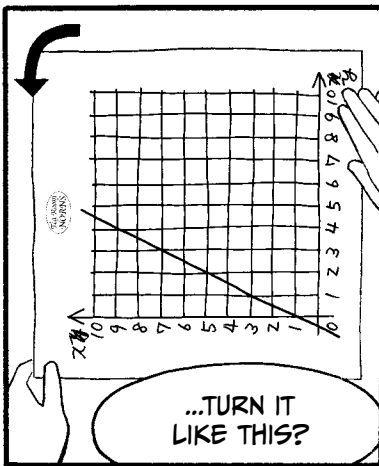
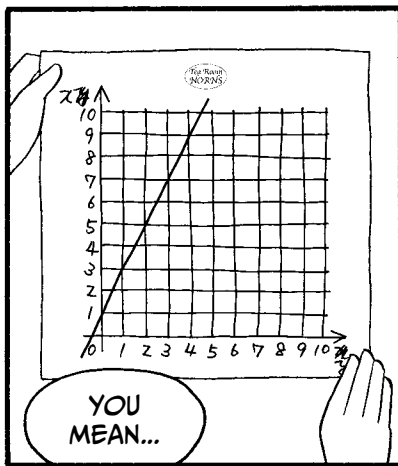
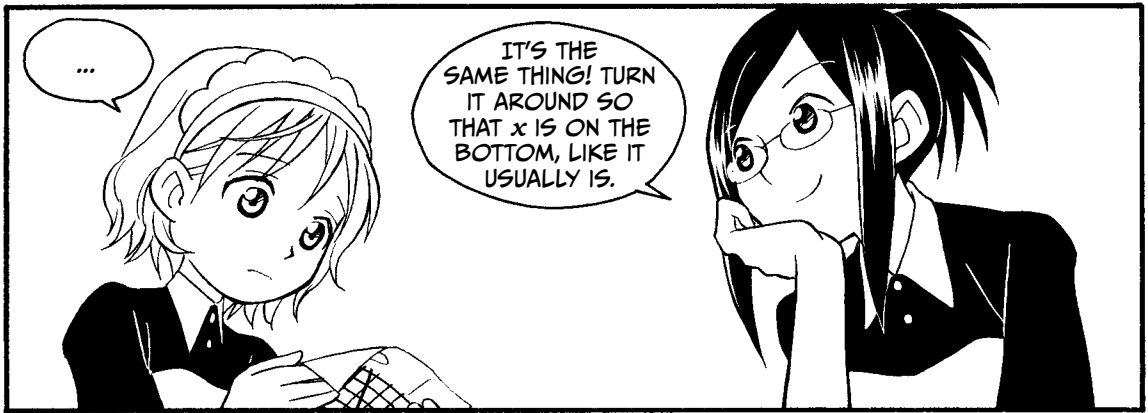

EXPONENTS AND LOGARITHMS

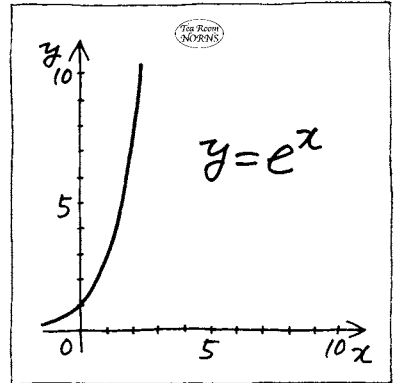
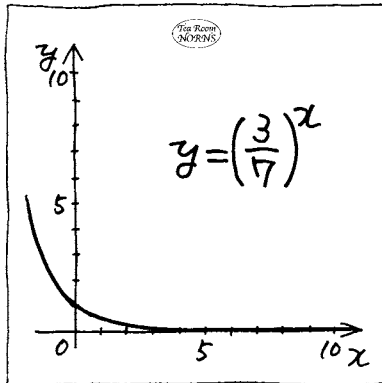
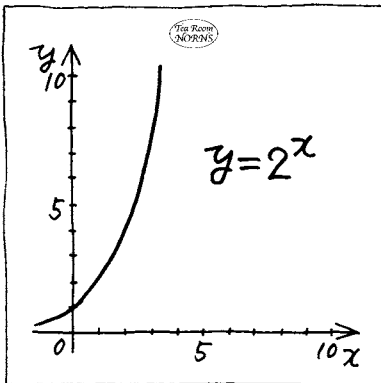

OKAY...

ON TO THE NEXT LESSON. THESE ARE CALLED EXPONENTIAL FUNCTIONS.

THEY ALL CROSS THE POINT (0,1) BECAUSE ANY NUMBER TO THE ZERO POWER IS 1.

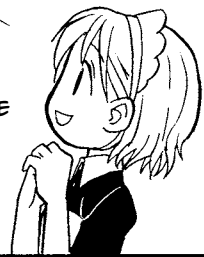

RIGHT! NOW, HAVE YOU SEEN THIS e BEFORE?

$y = e^x$

THIS e IS THE BASE OF THE NATURAL LOGARITHM AND HAS A VALUE OF 2.7182.

IT'S CALLED EULER'S NUMBER.

I'VE HEARD OF IT.

$\log_e y = x$ IS THE INVERSE OF THE EXPONENTIAL EQUATION $y = e^x$.

AH! MORE INVERSE FUNCTIONS!

FLIP!

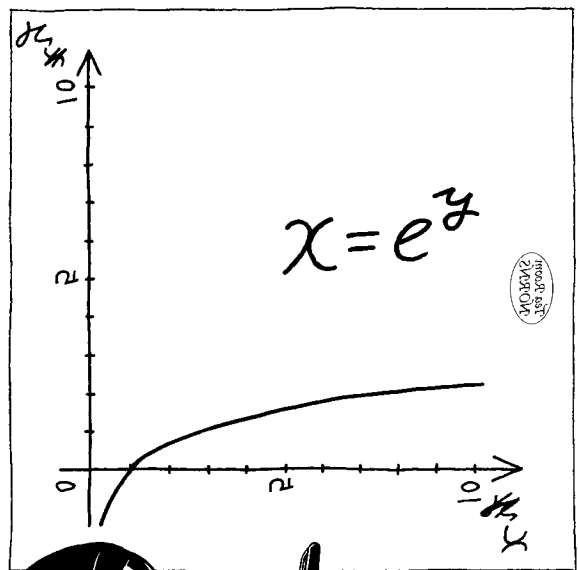
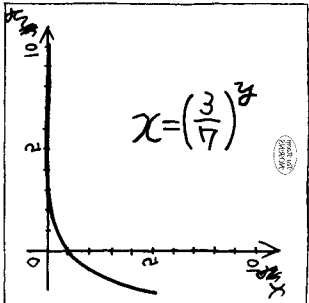
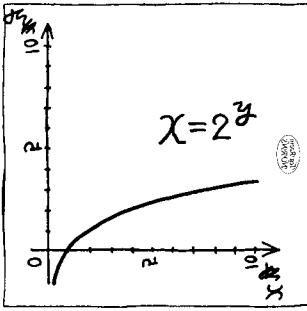

$x = e^y$ IS THE INVERSE FUNCTION OF $y = \log_e x$, WHICH IS THE NATURAL LOGARITHM FUNCTION.

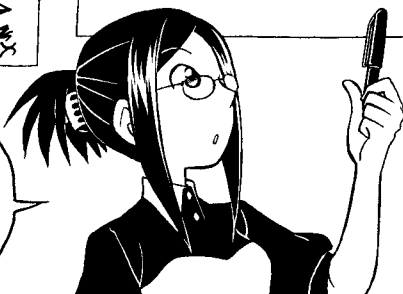

FLIPPED AGAIN!

TO FIND THE INVERSE OF $y = e^x$, WE'LL SWITCH THE VARIABLES x AND y AND THEN TAKE THEIR LOGARITHM TO ISOLATE y . WHEN WE SIMPLIFY $\log_e(e^y)$, IT'S JUST y !

$y = e^x$

SWITCH THE VARIABLES!

$x = e^y$

$y = \log_e x$

WE FLIPPED THE EQUATION TO PUT y BACK ON THE LEFT.

NEXT, I'LL GO OVER THE RULES OF EXPONENTIAL AND LOGARITHMIC FUNCTIONS.

REMEMBER THIS—YOU'LL NEED IT LATER!

I'M TAKING NOTES!

RULES FOR EXPONENTS AND LOGARITHMS

1. POWER RULE

$(e^a)^b$ AND $e^{a \times b}$ ARE EQUAL.



Let's try this. We'll confirm that $(e^a)^b$ and $e^{a \times b}$ are equal when $a = 2$ and $b = 3$.

$$(e^2)^3 = \underbrace{e^2 \times e^2 \times e^2}_3 = \underbrace{(e \times e) \times (e \times e) \times (e \times e)}_3 = \underbrace{e \times e \times e \times e \times e \times e}_6 = e^{2 \times 3}$$

This also means $(e^a)^b = e^{a \times b} = (e^b)^a$.



2. QUOTIENT RULE

$\frac{e^a}{e^b}$ AND e^{a-b} ARE EQUAL.

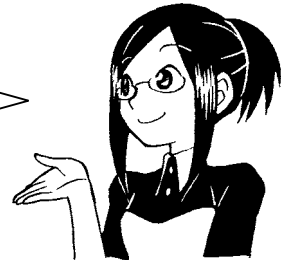

Now let's try this, too. We'll confirm that $\frac{e^a}{e^b}$ and e^{a-b} are equal when $a = 3$ and $b = 5$.

$$\frac{e^3}{e^5} = \frac{e \times e \times e}{e \times e \times e \times e \times e} = \frac{\cancel{e} \times \cancel{e} \times \cancel{e}}{e \times e \times \cancel{e} \times \cancel{e} \times \cancel{e}} = \frac{1}{e^2} = e^{-2} = e^{3-5}$$

3. CANCELING EXPONENTIALS RULE

a AND $\log_e(e^a)$ ARE EQUAL.



As mentioned page 20, $y = \log_e x$ and $x = e^y$ are equivalent. First we need to look at what a logarithm is. An exponential function of base b to a power, n , equals a value, x . The logarithm function inverts this process. That means the logarithm base b of a value, x , equals a power, n .

We see that in $\log_e(e^a) = n$, the base b is e and the value x is e^a , so $e^n = e^a$ and $n = a$.

$$\begin{array}{ccc} \text{So } b^n = x \text{ also means } \log_b x = n. & & \\ \uparrow \quad \uparrow & & \uparrow \\ \text{base} \quad \text{value} & & \text{power} \end{array}$$



4. EXPONENTIATION RULE

$\log_e(a^b)$ AND $b \times \log_e(a)$ ARE EQUAL.



Let's confirm that $\log_e(a^b)$ and $b \times \log_e(a)$ are equal. We'll start by using $b \times \log_e(a)$ and e in the Power Rule:

$$e^{b \times \log_e(a)} = \left(e^{\log_e(a)} \right)^b$$

And since e is the inverse of \log_e , we can reduce $e^{b \times \log_e(a)}$ on the right side to just a :

$$e^{b \times \log_e(a)} = a^b$$

Now we'll use the rule that $b^n = x$ also means $\log_b x = n$, where:

$$\begin{array}{l} b = e \\ x = a^b \\ n = b \times \log_e(a) \end{array}$$

This means that $e^{b \times \log_e(a)} = a^b$, so we can conclude that $\log_e(a^b)$ is equal to $b \times \log_e(a)$.

5. PRODUCT RULE

$\log_e(a) + \log_e(b)$ AND
 $\log_e(a \times b)$ ARE EQUAL.



Let's confirm that $\log_e(a) + \log_e(b)$ and $\log_e(a \times b)$ are equal. Again, we'll use the rule that states that $b^n = x$ also means $\log_b x = n$.

Let's start by defining $e^m = a$ and $e^n = b$. We would then have $e^m e^n = e^{m+n} = a \times b$, thanks to the Product Rule of exponents. We can then take the log of both sides,

$$\log_e(e^{m+n}) = \log_e(a \times b),$$

which on the left side reduces simply to

$$m + n = \log_e(a \times b).$$

We also know that $m + n = \log_e a + \log_e b$, so clearly

$$\log_e(a) + \log_e(b) = \log_e(a \times b).$$



HERE I HAVE SUMMARIZED THE RULES
I'VE EXPLAINED SO FAR.

RULE 1	$(e^a)^b$ and e^{ab} are equal.
RULE 2	$\frac{e^a}{e^b}$ and e^{a-b} are equal.
RULE 3	a and $\log_e(e^a)$ are equal.
RULE 4	$\log_e(a^b)$ and $b \times \log_e(a)$ are equal.
RULE 5	$\log_e(a) + \log_e(a)$ and $\log_e(a \times b)$ are equal.



In fact, one could replace the natural number e in these equations with any positive real number d . Can you prove these rules again using d as the base?

DIFFERENTIAL CALCULUS

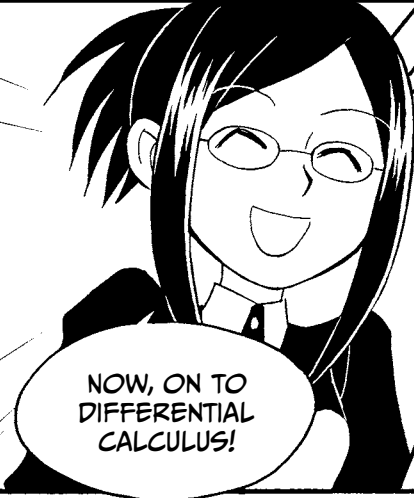

NOW, ON TO DIFFERENTIAL CALCULUS!



FAINT

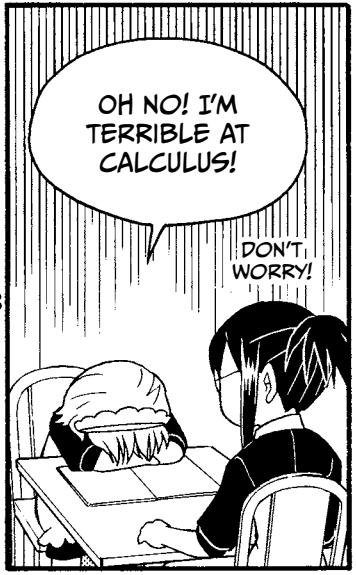

OH NO! I'M TERRIBLE AT CALCULUS!

DON'T WORRY!

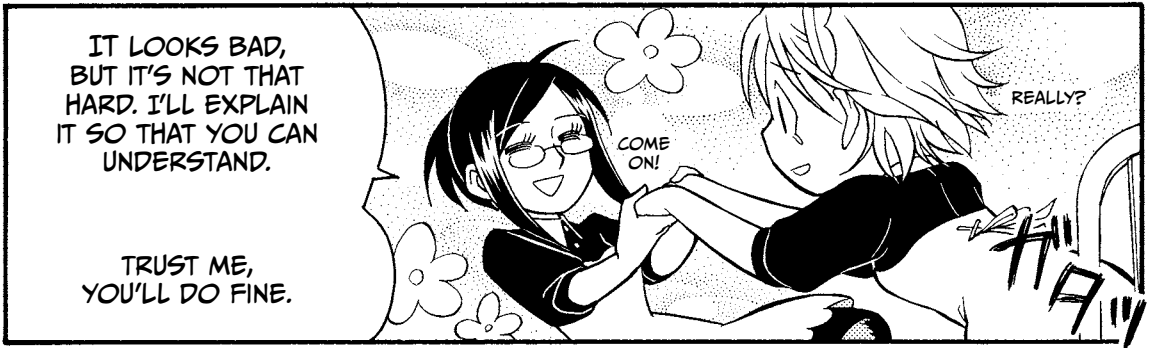

IT LOOKS BAD, BUT IT'S NOT THAT HARD. I'LL EXPLAIN IT SO THAT YOU CAN UNDERSTAND.

TRUST ME, YOU'LL DO FINE.

COME ON!

REALLY?

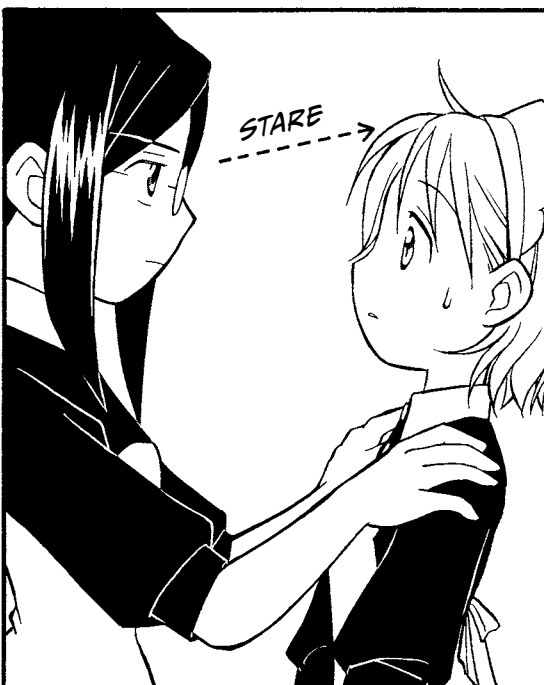

STARE



YOU MUST BE ABOUT 156 CM.

155.7 CM, TO BE PRECISE.

Wow, GOOD GUESS!

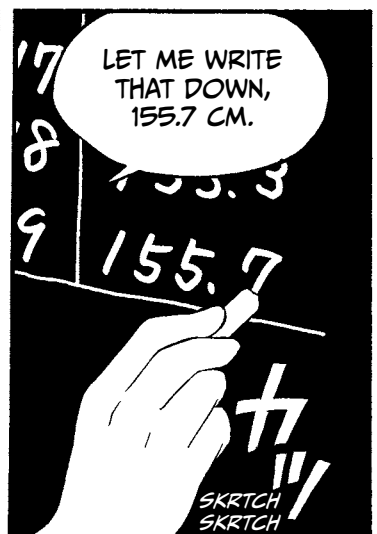

LET ME WRITE THAT DOWN, 155.7 CM.

155.7

SKRTCH SKRTCH

MIU'S AGE AND HEIGHT

AGE	HEIGHT
4	100.1
5	107.2
6	114.1
7	121.7
8	126.8
9	130.9
10	137.5
11	143.2
12	149.4
13	151.1
14	154.0
15	154.6
16	155.0
17	155.1
18	155.3
19	155.7

THIS IS A TABLE SHOWING YOUR HEIGHT FROM AGE 4 UP TO NOW.

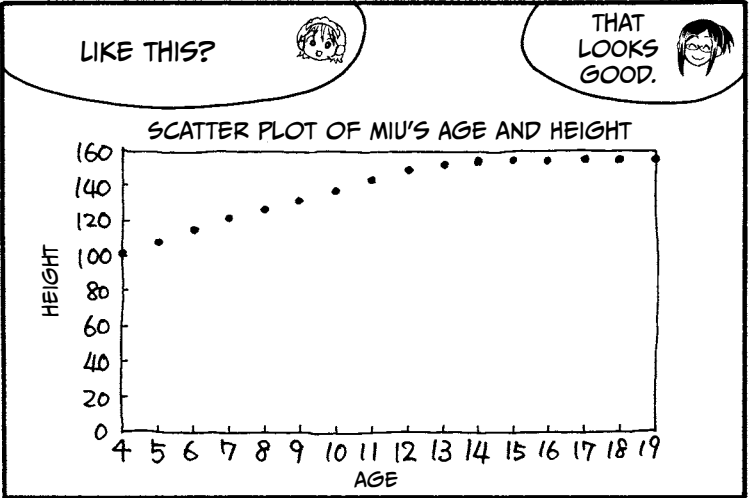
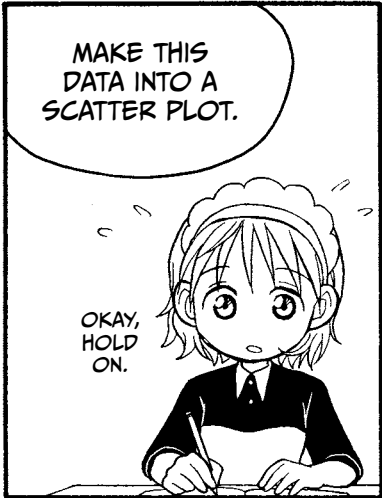
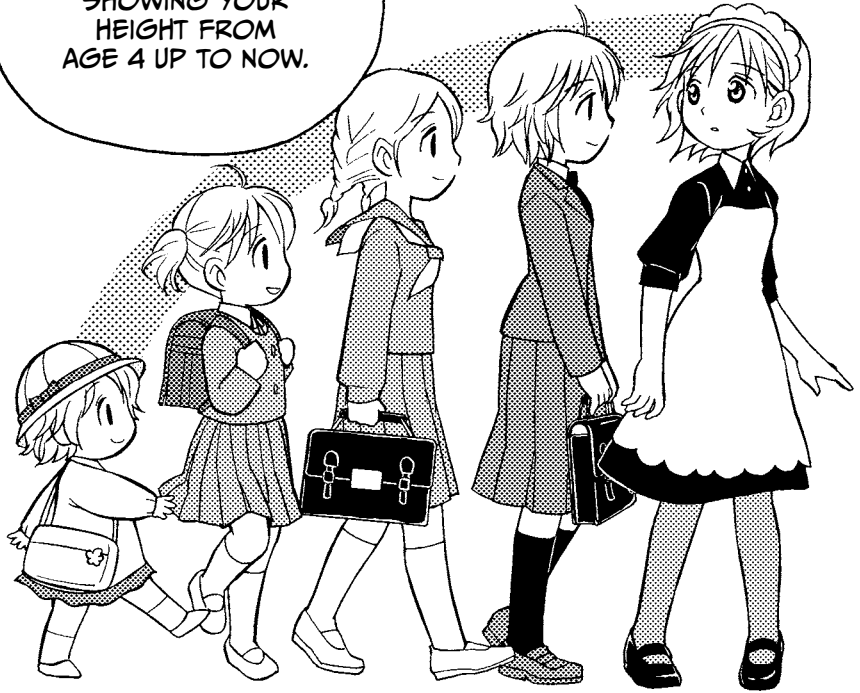

WHERE DID THAT

$$y = -\frac{326.6}{x} + 173.3$$

 FUNCTION COME FROM?!

SHOCKED
 HEE HEE

THAT IS A REGRESSION EQUATION! DON'T WORRY ABOUT HOW TO GET IT RIGHT NOW.

JUST ASSUME IT DESCRIBES THE RELATIONSHIP BETWEEN YOUR AGE AND YOUR HEIGHT.

OKAY, RISA.

FOR NOW, I'LL JUST BELIEVE THAT THE RELATIONSHIP IS

$$y = -\frac{326.6}{x} + 173.3.$$

GREAT.

NOW, CAN YOU SEE THAT "7 YEARS OLD" CAN BE DESCRIBED AS "(6 + 1) YEARS OLD"?

WELL YEAH, THAT MAKES SENSE.

SO USING THE EQUATION, YOUR INCREASE IN HEIGHT BETWEEN AGE 6 AND AGE (6 + 1) CAN BE DESCRIBED AS...

HEIGHT AT AGE (6 + 1) HEIGHT AT AGE 6

$$\left(-\frac{326.6}{(6+1)} + 173.3\right) - \left(-\frac{326.6}{6} + 173.3\right)$$

WE REPLACE x WITH YOUR AGE.

I SEE.

WE CAN SHOW THE RATE OF GROWTH AS CENTIMETERS PER YEAR, SINCE THERE IS ONE YEAR BETWEEN THE AGES WE USED.

$$\frac{\left(-\frac{326.6}{(6+1)} + 173.3\right) - \left(-\frac{326.6}{6} + 173.3\right)}{1} \text{ CM/YEAR}$$



OH! YOU DIVIDED THE PREVIOUS FORMULA BY 1 BECAUSE THE INTERVAL IS ONE YEAR.



NEXT, LET'S THINK ABOUT THE INCREASE IN HEIGHT IN HALF A YEAR.

6 6½ 7

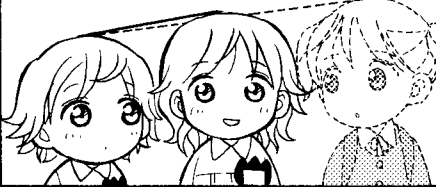

WHAT IS AGE SIX AND A HALF IN TERMS OF THE NUMBER 6?

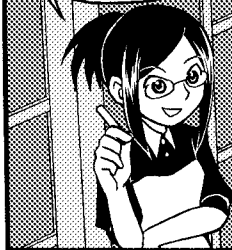

LET ME SEE... (6 + 0.5) YEARS OLD?

CORRECT!



THE INCREASE IN HEIGHT IN 0.5 YEARS, BETWEEN AGE 6 AND AGE (6 + 0.5)...

HEIGHT AT AGE (6 + 0.5)

HEIGHT AT AGE 6

$$\left(-\frac{326.6}{(6+0.5)} + 173.3\right) - \left(-\frac{326.6}{6} + 173.3\right)$$

...CAN BE WRITTEN LIKE THIS.

I SEE.

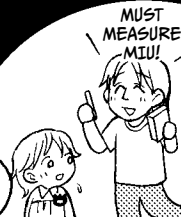

AND THIS IS THE INCREASE IN HEIGHT PER YEAR, BETWEEN AGE 6 AND AGE (6 + 0.5).

$$\frac{\left(-\frac{326.6}{(6+0.5)} + 173.3\right) - \left(-\frac{326.6}{6} + 173.3\right)}{0.5} \text{ CM/YEAR}$$

THIS TIME YOU DIVIDED THE FORMULA BY 0.5 BECAUSE THE INTERVAL IS HALF A YEAR. I GET IT!



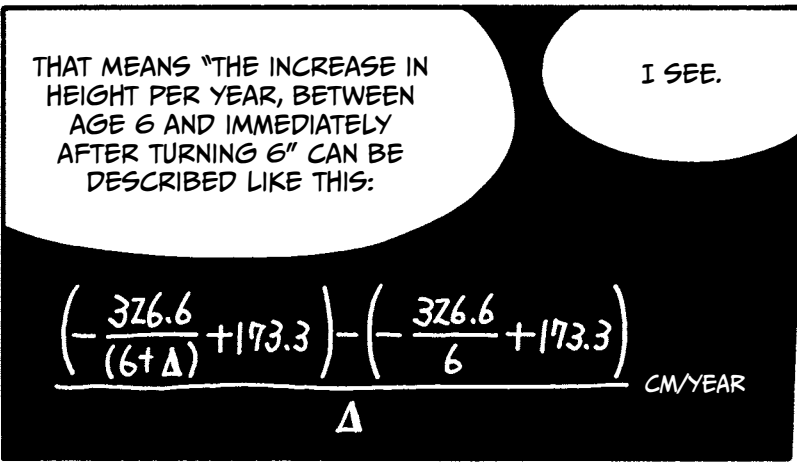
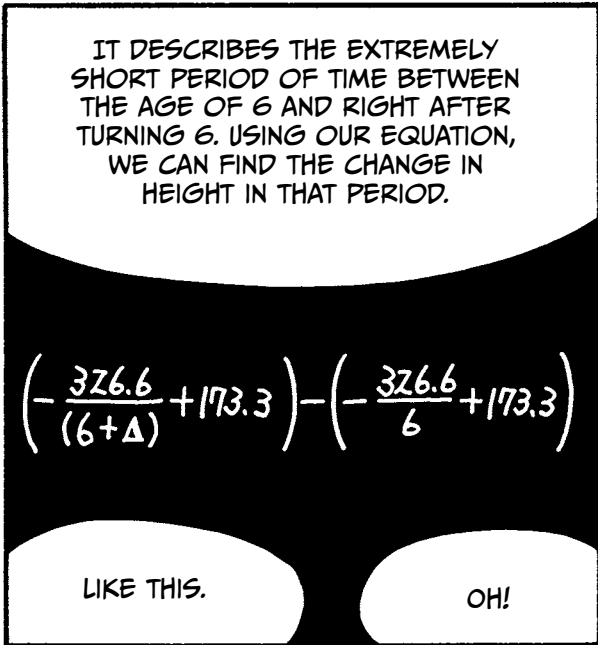
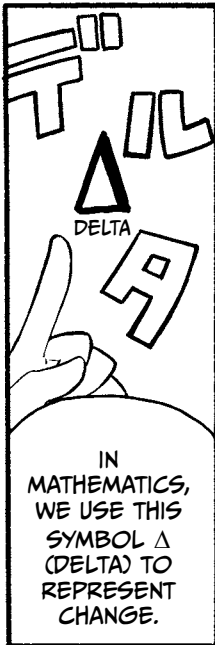
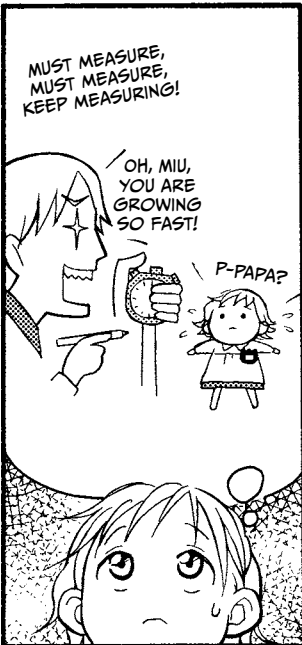
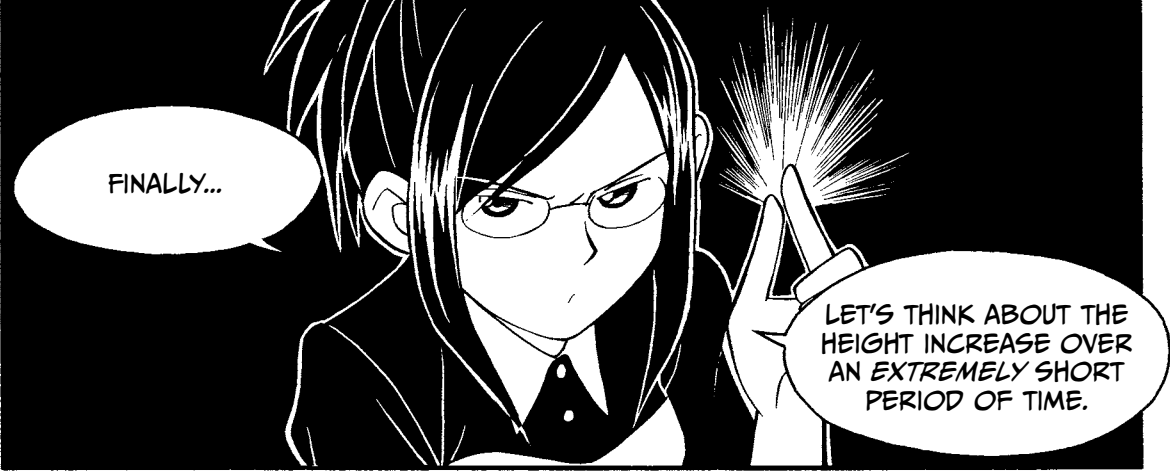

$$\frac{\left(-\frac{376.6}{(6+\Delta)} + 173.3\right) - \left(-\frac{376.6}{6} + 173.3\right)}{\Delta}$$

$$= \frac{-\frac{376.6}{(6+\Delta)} + \frac{376.6}{6}}{\Delta}$$

$$= \frac{\frac{376.6}{6} - \frac{376.6}{(6+\Delta)}}{\Delta}$$

$$= \frac{376.6 \times \left(\frac{1}{6} - \frac{1}{(6+\Delta)}\right)}{\Delta}$$

$$= \frac{376.6 \times \frac{(6+\Delta) - 6}{6(6+\Delta)}}{\Delta}$$

$$= \frac{376.6 \times \frac{\Delta}{6(6+\Delta)}}{\Delta}$$

$$= 376.6 \times \frac{\Delta}{6(6+\Delta)} \times \frac{1}{\Delta}$$

$$= 376.6 \times \frac{1}{6(6+\Delta)}$$

$$\approx 376.6 \times \frac{1}{6(6+0)} = 376.6 \times \frac{1}{6^2 \text{ CM/YEAR}}$$

I CHANGED THE REMAINING Δ TO ZERO BECAUSE VIRTUALLY NO TIME HAS PASSED.



ARE YOU FOLLOWING SO FAR? THERE ARE A LOT OF STEPS IN THIS CALCULATION, BUT IT'S NOT TOO HARD, IS IT?

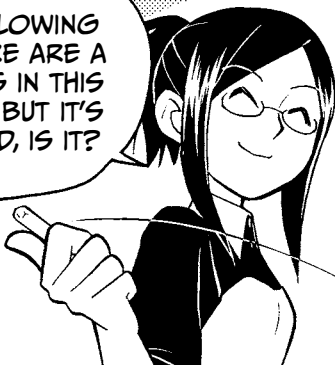

NO, I THINK I CAN HANDLE THIS.



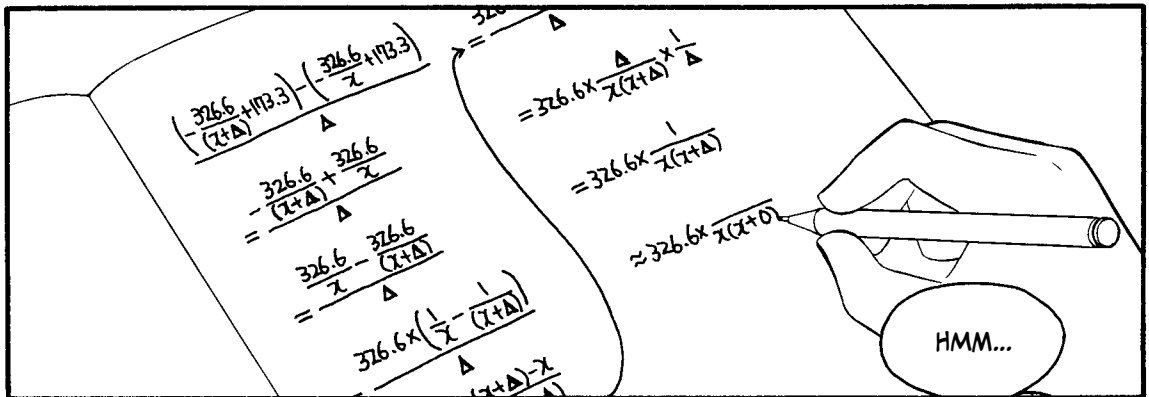
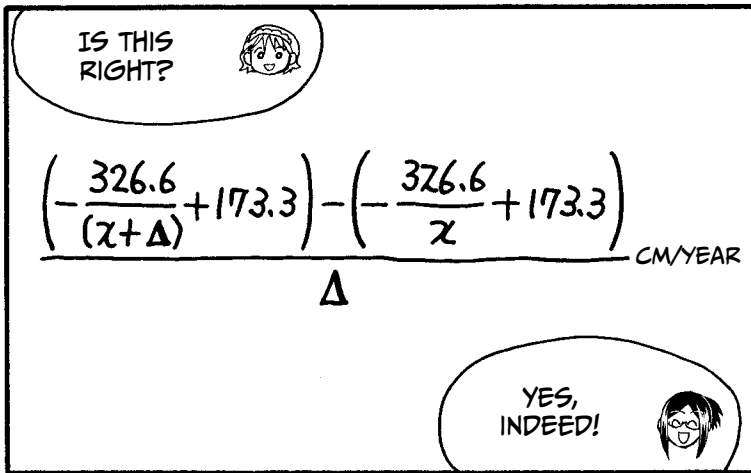
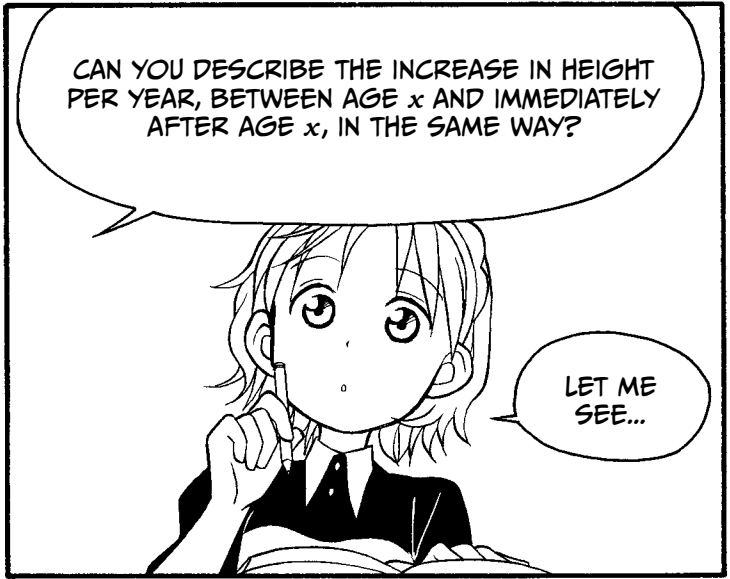

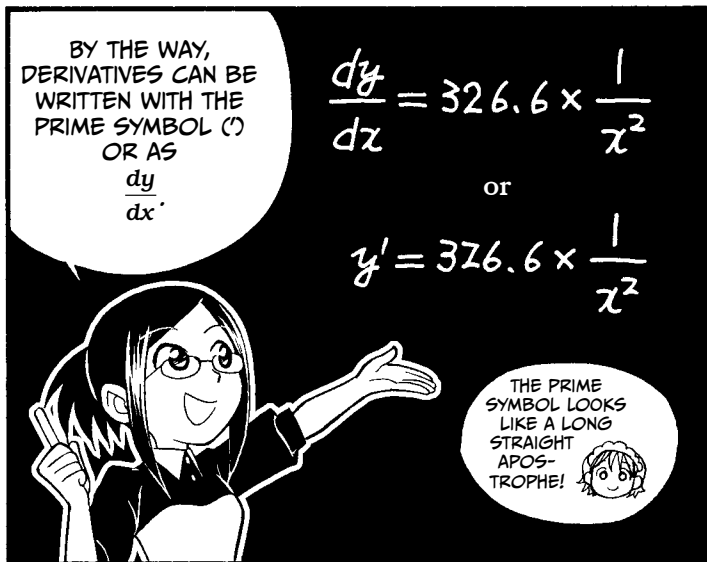
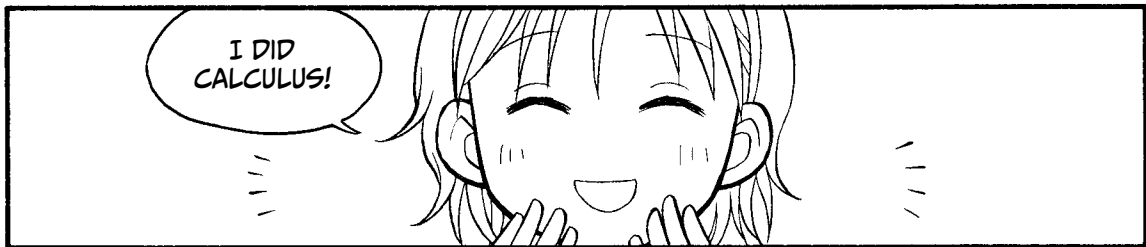
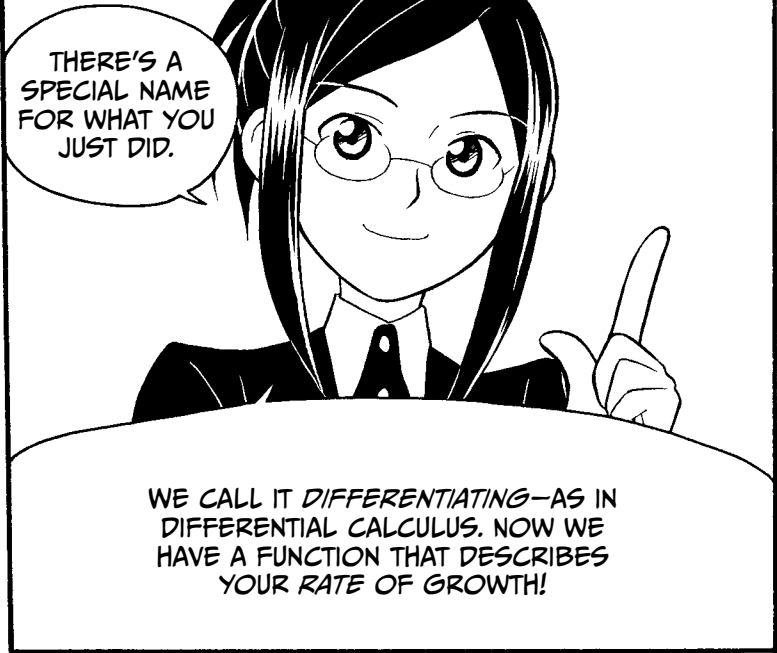
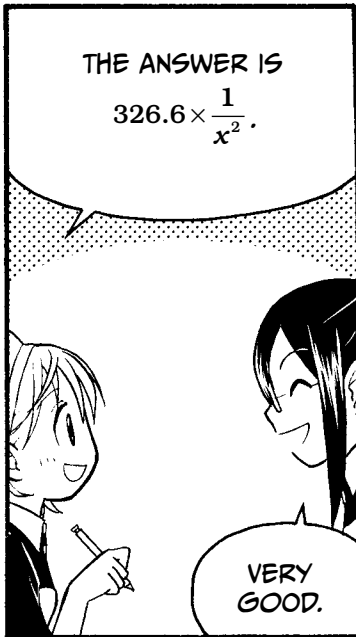

DIFFERENTIATE $y = x$ WITH RESPECT TO x .



$$\frac{(x + \Delta) - x}{\Delta} = \frac{\Delta}{\Delta} = 1 \quad \text{SO } \frac{dy}{dx} = 1$$

IT'S A CONSTANT RATE OF CHANGE!

DIFFERENTIATE $y = x^2$ WITH RESPECT TO x .



$$\frac{(x + \Delta)^2 - x^2}{\Delta} = \frac{x^2 + 2x\Delta + \Delta^2 - x^2}{\Delta} = \frac{(2x + \Delta)\Delta}{\Delta} = 2x + \Delta$$
$$\approx 2x + 0 = 2x \quad \text{SO } \frac{dy}{dx} = 2x$$

DIFFERENTIATE $y = \frac{1}{x}$ WITH RESPECT TO x .



$$\frac{\frac{1}{x + \Delta} - \frac{1}{x}}{\Delta} = \frac{\frac{x - (x + \Delta)}{(x + \Delta)x}}{\Delta} = \frac{-\Delta}{(x + \Delta)x} \times \frac{1}{\Delta} = \frac{-1}{(x + \Delta)x}$$
$$\approx \frac{-1}{(x + 0)x} = \frac{-1}{x^2} = -x^{-2} \quad \text{SO } \frac{dy}{dx} = -x^{-2}$$

DIFFERENTIATE $y = \frac{1}{x^2}$ WITH RESPECT TO x .



$$\frac{\frac{1}{(x+\Delta)^2} - \frac{1}{x^2}}{\Delta}$$

$$= \frac{\left(\frac{1}{x+\Delta}\right)^2 - \left(\frac{1}{x}\right)^2}{\Delta}$$

$$= \frac{\left(\frac{1}{x+\Delta} + \frac{1}{x}\right)\left(\frac{1}{x+\Delta} - \frac{1}{x}\right)}{\Delta}$$

$$= \frac{\frac{x+(x+\Delta)}{(x+\Delta)x} \times \frac{x-(x+\Delta)}{(x+\Delta)x}}{\Delta}$$

$$= \frac{\frac{2x+\Delta}{(x+\Delta)x} \times \frac{-\Delta}{(x+\Delta)x}}{\Delta}$$

$$= \frac{2x+\Delta}{(x+\Delta)x} \times \frac{-\Delta}{(x+\Delta)x} \times \frac{1}{\Delta}$$

$$= \frac{-(2x+\Delta)}{[(x+\Delta)x]^2}$$

$$\approx \frac{-(2x+0)}{[(x+0)x]^2}$$

$$= \frac{-2x}{x^4}$$

$$= \frac{-2}{x^3}$$

$$= -2x^{-3}$$

$$\text{SO } \frac{dy}{dx} = -2x^{-3}$$

BASED ON THESE EXAMPLES,
YOU CAN SEE THAT WHEN YOU DIFFERENTIATE $y = x^n$
WITH RESPECT TO x , THE RESULT IS $\frac{dy}{dx} = nx^{n-1}$.



DIFFERENTIATE $y = (5x - 7)^2$ WITH RESPECT TO x .

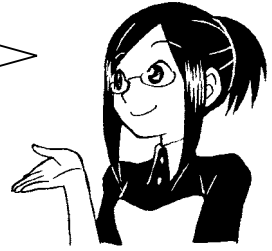

$$\begin{aligned} & \frac{\{5(x + \Delta) - 7\}^2 - (5x - 7)^2}{\Delta} \\ &= \frac{[\{5(x + \Delta) - 7\} + (5x - 7)][\{5(x + \Delta) - 7\} - (5x - 7)]}{\Delta} \\ &= \frac{[2(5x - 7) + 5\Delta] \times 5\Delta}{\Delta} \\ &= [2(5x - 7) + 5\Delta] \times 5 \\ &\approx [2(5x - 7) + 5 \times 0] \times 5 \\ &= 2(5x - 7) \times 5 \end{aligned}$$

$$\text{SO } \frac{dy}{dx} = 2(5x - 7) \times 5$$

WHEN YOU DIFFERENTIATE $y = (ax + b)^n$ WITH RESPECT TO x , THE RESULT IS $\frac{dy}{dx} = n(ax + b)^{n-1} \times a$.



HERE ARE SOME OTHER EXAMPLES OF
COMMON DERIVATIVES:

- WHEN YOU DIFFERENTIATE $y = e^x$, $\frac{dy}{dx} = e^x$.
- WHEN YOU DIFFERENTIATE $y = \log x$, $\frac{dy}{dx} = \frac{1}{x}$.
- WHEN YOU DIFFERENTIATE $y = \log(ax + b)$,
 $\frac{dy}{dx} = \frac{a}{ax + b}$.
- WHEN YOU DIFFERENTIATE $y = \log(1 + e^{ax+b})$,
 $\frac{dy}{dx} = a - \frac{a}{1 + e^{ax+b}}$.

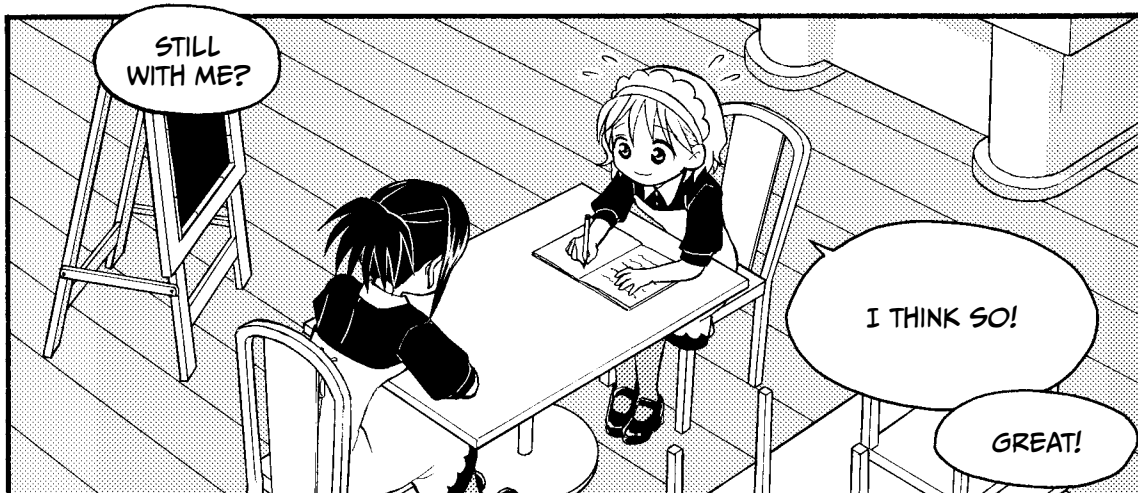

MATRICES

術*



* MATRICES

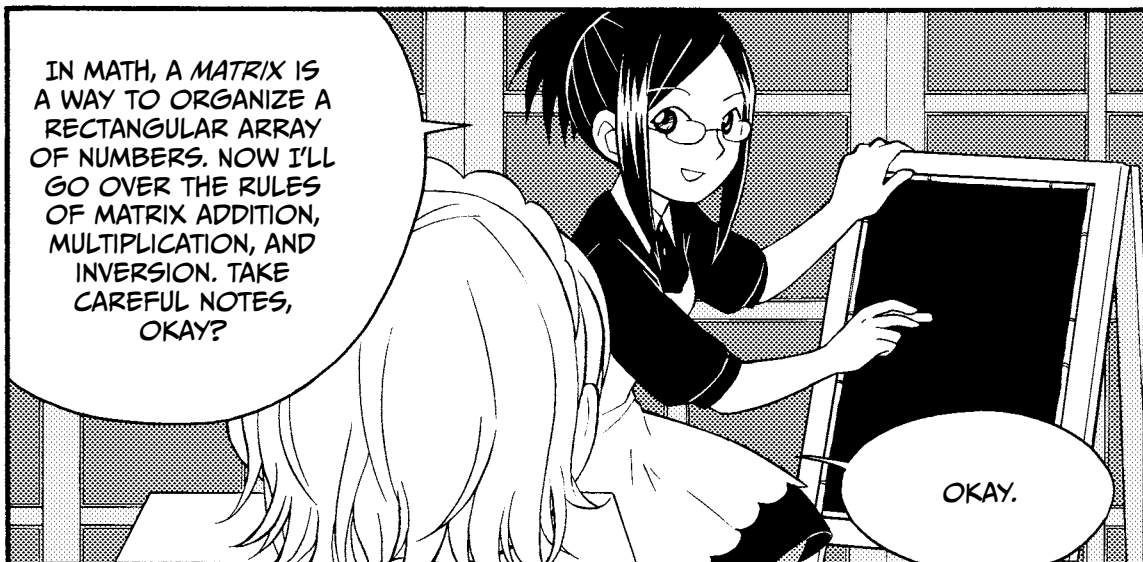
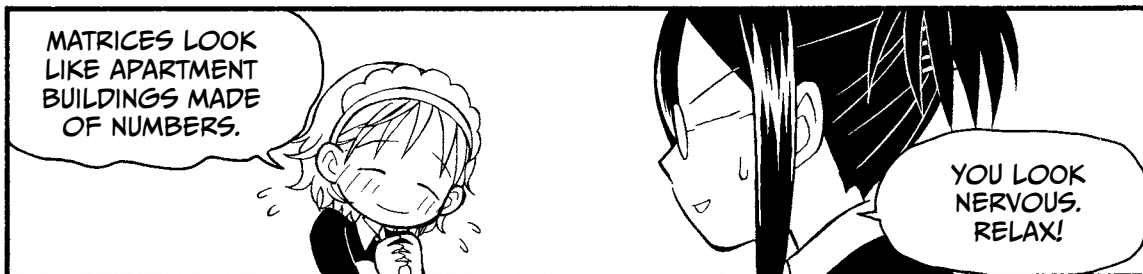
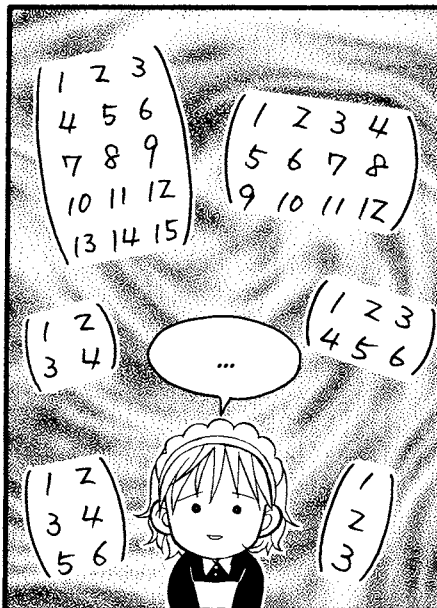

A MATRIX CAN BE USED TO WRITE EQUATIONS QUICKLY. JUST AS WITH EXPONENTS, MATHEMATICIANS HAVE RULES FOR WRITING THEM.

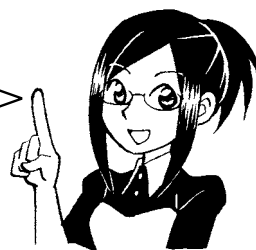

$$\begin{cases} x_1 + 2x_2 = -1 \\ 3x_1 + 4x_2 = 5 \end{cases} \text{ CAN BE WRITTEN AS } \begin{pmatrix} 1 & 2 \\ 3 & 4 \end{pmatrix} \begin{pmatrix} x_1 \\ x_2 \end{pmatrix} = \begin{pmatrix} -1 \\ 5 \end{pmatrix}$$

$$\text{AND } \begin{cases} x_1 + 2x_2 \\ 3x_1 + 4x_2 \end{cases} \text{ CAN BE WRITTEN AS } \begin{pmatrix} 1 & 2 \\ 3 & 4 \end{pmatrix} \begin{pmatrix} x_1 \\ x_2 \end{pmatrix}$$

EXAMPLE

$$\begin{cases} k_1 + 2k_2 + 3k_3 = -3 \\ 4k_1 + 5k_2 + 6k_3 = 8 \\ 10k_1 + 11k_2 + 12k_3 = 2 \\ 13k_1 + 14k_2 + 15k_3 = 7 \end{cases} \text{ can be written as } \begin{pmatrix} 1 & 2 & 3 \\ 4 & 5 & 6 \\ 10 & 11 & 12 \\ 13 & 14 & 15 \end{pmatrix} \begin{pmatrix} k_1 \\ k_2 \\ k_3 \end{pmatrix} = \begin{pmatrix} -3 \\ 8 \\ 2 \\ 7 \end{pmatrix}$$

If you don't know the values of the expressions, you write the expressions and the matrix like this:

$$\begin{cases} k_1 + 2k_2 + 3k_3 \\ 4k_1 + 5k_2 + 6k_3 \\ 7k_1 + 8k_2 + 9k_3 \\ 10k_1 + 11k_2 + 12k_3 \\ 13k_1 + 14k_2 + 15k_3 \end{cases} \begin{pmatrix} 1 & 2 & 3 \\ 4 & 5 & 6 \\ 7 & 8 & 9 \\ 10 & 11 & 12 \\ 13 & 14 & 15 \end{pmatrix} \begin{pmatrix} k_1 \\ k_2 \\ k_3 \end{pmatrix}$$

Just like an ordinary table, we say matrices have *columns* and *rows*. Each number inside of the matrix is called an *element*.

SUMMARY

$$\begin{cases} a_{11}x_1 + a_{12}x_2 + \dots + a_{1q}x_q = b_1 \\ a_{21}x_2 + a_{22}x_2 + \dots + a_{2q}x_q = b_2 \\ \dots \\ a_{p1}x_1 + a_{p2}x_2 + \dots + a_{pq}x_q = b_p \end{cases} \text{ can be written as } \begin{pmatrix} a_{11} & a_{12} & \dots & a_{1q} \\ a_{21} & a_{22} & \dots & a_{2q} \\ \vdots & \vdots & \ddots & \vdots \\ a_{p1} & a_{p2} & \dots & a_{pq} \end{pmatrix} \begin{pmatrix} x_1 \\ x_2 \\ \vdots \\ x_q \end{pmatrix} = \begin{pmatrix} b_1 \\ b_2 \\ \vdots \\ b_p \end{pmatrix}$$

$$\begin{cases} a_{11}x_1 + a_{12}x_2 + \dots + a_{1q}x_q \\ a_{21}x_2 + a_{22}x_2 + \dots + a_{2q}x_q \\ \dots \\ a_{p1}x_1 + a_{p2}x_2 + \dots + a_{pq}x_q \end{cases} \text{ can be written as } \begin{pmatrix} a_{11} & a_{12} & \dots & a_{1q} \\ a_{21} & a_{22} & \dots & a_{2q} \\ \vdots & \vdots & \ddots & \vdots \\ a_{p1} & a_{p2} & \dots & a_{pq} \end{pmatrix} \begin{pmatrix} x_1 \\ x_2 \\ \vdots \\ x_q \end{pmatrix}$$

ADDING MATRICES

NEXT, I'LL EXPLAIN THE ADDITION OF MATRICES.

CONSIDER THIS: $\begin{pmatrix} 1 & 2 \\ 3 & 4 \end{pmatrix} + \begin{pmatrix} 4 & 5 \\ -2 & 4 \end{pmatrix}$

NOW JUST ADD THE NUMBERS IN THE SAME POSITION: TOP LEFT PLUS TOP LEFT, AND SO ON.

$$\begin{pmatrix} 1+4 & 2+5 \\ 3+(-2) & 4+4 \end{pmatrix} = \begin{pmatrix} 5 & 7 \\ 1 & 8 \end{pmatrix}$$

YOU CAN ONLY ADD MATRICES THAT HAVE THE SAME DIMENSIONS, THAT IS, THE SAME NUMBER OF ROWS AND COLUMNS.



EXAMPLE PROBLEM 1

What is $\begin{pmatrix} 5 & 1 \\ 6 & -9 \end{pmatrix} + \begin{pmatrix} -1 & 3 \\ -3 & 10 \end{pmatrix}$?

ANSWER

$$\begin{pmatrix} 5 & 1 \\ 6 & -9 \end{pmatrix} + \begin{pmatrix} -1 & 3 \\ -3 & 10 \end{pmatrix} = \begin{pmatrix} 5+(-1) & 1+3 \\ 6+(-3) & (-9)+10 \end{pmatrix} = \begin{pmatrix} 4 & 4 \\ 3 & 1 \end{pmatrix}$$

EXAMPLE PROBLEM 2

What is $\begin{pmatrix} 1 & 2 & 3 \\ 4 & 5 & 6 \\ 7 & 8 & 9 \\ 10 & 11 & 12 \\ 13 & 14 & 15 \end{pmatrix} + \begin{pmatrix} 7 & 2 & 3 \\ -1 & 7 & -4 \\ -7 & -3 & 10 \\ 8 & 2 & -1 \\ 7 & 1 & -9 \end{pmatrix}$?

ANSWER

$$\begin{pmatrix} 1 & 2 & 3 \\ 4 & 5 & 6 \\ 7 & 8 & 9 \\ 10 & 11 & 12 \\ 13 & 14 & 15 \end{pmatrix} + \begin{pmatrix} 7 & 2 & 3 \\ -1 & 7 & -4 \\ -7 & -3 & 10 \\ 8 & 2 & -1 \\ 7 & 1 & -9 \end{pmatrix} = \begin{pmatrix} 1+7 & 2+2 & 3+3 \\ 4+(-1) & 5+7 & 6+(-4) \\ 7+(-7) & 8+(-3) & 9+10 \\ 10+8 & 11+2 & 12+(-1) \\ 13+7 & 14+1 & 15+(-9) \end{pmatrix} = \begin{pmatrix} 8 & 4 & 6 \\ 3 & 12 & 2 \\ 0 & 5 & 19 \\ 18 & 13 & 11 \\ 20 & 15 & 6 \end{pmatrix}$$

SUMMARY

Here are two generic matrices.

$$\begin{pmatrix} a_{11} & a_{12} & \cdots & a_{1q} \\ a_{21} & a_{22} & \cdots & a_{2q} \\ \vdots & \vdots & \ddots & \vdots \\ a_{p1} & a_{p2} & \cdots & a_{pq} \end{pmatrix} \begin{pmatrix} b_{11} & b_{12} & \cdots & b_{1q} \\ b_{21} & b_{22} & \cdots & b_{2q} \\ \vdots & \vdots & \ddots & \vdots \\ b_{p1} & b_{p2} & \cdots & b_{pq} \end{pmatrix}$$

You can add them together,

$$\begin{pmatrix} a_{11} & a_{12} & \cdots & a_{1q} \\ a_{21} & a_{22} & \cdots & a_{2q} \\ \vdots & \vdots & \ddots & \vdots \\ a_{p1} & a_{p2} & \cdots & a_{pq} \end{pmatrix} + \begin{pmatrix} b_{11} & b_{12} & \cdots & b_{1q} \\ b_{21} & b_{22} & \cdots & b_{2q} \\ \vdots & \vdots & \ddots & \vdots \\ b_{p1} & b_{p2} & \cdots & b_{pq} \end{pmatrix}$$

like this:

$$\begin{pmatrix} a_{11} + b_{11} & a_{12} + b_{12} & \cdots & a_{1q} + b_{1q} \\ a_{21} + b_{21} & a_{22} + b_{22} & \cdots & a_{2q} + b_{2q} \\ \vdots & \vdots & \ddots & \vdots \\ a_{p1} + b_{p1} & a_{p2} + b_{p2} & \cdots & a_{pq} + b_{pq} \end{pmatrix}$$

And of course, matrix subtraction works the same way. Just subtract the corresponding elements!

MULTIPLYING MATRICES

ON TO MATRIX MULTIPLICATION! WE DON'T MULTIPLY MATRICES IN THE SAME WAY AS WE ADD AND SUBTRACT THEM. IT'S EASIEST TO EXPLAIN BY EXAMPLE, SO LET'S MULTIPLY THE FOLLOWING:

$$\begin{pmatrix} 1 & 2 \\ 3 & 4 \end{pmatrix} \begin{pmatrix} x_1 & y_1 \\ x_2 & y_2 \end{pmatrix}$$



WE MULTIPLY EACH ELEMENT IN THE FIRST COLUMN OF THE LEFT MATRIX BY THE TOP ELEMENT OF THE SECOND COLUMN IN THE RIGHT MATRIX, THEN THE SECOND ELEMENT IN THE FIRST COLUMN OF THE RIGHT MATRIX. THEN WE ADD THE PRODUCTS, LIKE THIS:

$$1x_1 + 2x_2$$

$$3x_1 + 4x_2$$

AND THEN WE DO THE SAME WITH THE SECOND COLUMN OF THE RIGHT MATRIX TO GET:

$$1y_1 + 2y_2$$

$$3y_1 + 4y_2$$

SO THE FINAL RESULT IS:

$$\begin{pmatrix} 1x_1 + 2x_2 & 1y_1 + 2y_2 \\ 3x_1 + 4x_2 & 3y_1 + 4y_2 \end{pmatrix}$$

IN MATRIX MULTIPLICATION, FIRST YOU MULTIPLY AND THEN YOU ADD TO GET THE FINAL RESULT. LET'S TRY THIS OUT.

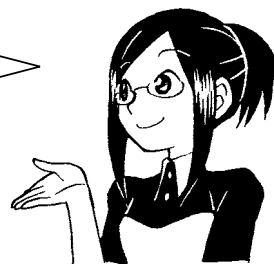

EXAMPLE PROBLEM 1

What is $\begin{pmatrix} 1 & 2 \\ 3 & 4 \end{pmatrix} \begin{pmatrix} 4 & 5 \\ -2 & 4 \end{pmatrix}$?

We know to multiply the elements and then add the terms to simplify. When multiplying, we take the right matrix, column by column, and multiply it by the left matrix.*

ANSWER

$$\begin{pmatrix} 1 & 2 \\ 3 & 4 \end{pmatrix} \begin{pmatrix} 4 \\ -2 \end{pmatrix} = \begin{pmatrix} 1 \times 4 + 2 \times (-2) \\ 3 \times 4 + 4 \times (-2) \end{pmatrix} = \begin{pmatrix} 0 \\ 4 \end{pmatrix}$$

First column

$$\begin{pmatrix} 1 & 2 \\ 3 & 4 \end{pmatrix} \begin{pmatrix} 5 \\ 4 \end{pmatrix} = \begin{pmatrix} 1 \times 5 + 2 \times 4 \\ 3 \times 5 + 4 \times 4 \end{pmatrix} = \begin{pmatrix} 13 \\ 31 \end{pmatrix}$$

Second column

So the answer is $\begin{pmatrix} 1 & 2 \\ 3 & 4 \end{pmatrix} \begin{pmatrix} 4 & 5 \\ -2 & 4 \end{pmatrix} = \begin{pmatrix} 0 & 13 \\ 4 & 31 \end{pmatrix}$.

* NOTE THAT THE RESULTING MATRIX WILL HAVE THE SAME NUMBER OF ROWS AS THE FIRST MATRIX AND THE SAME NUMBER OF COLUMNS AS THE SECOND MATRIX.

EXAMPLE PROBLEM 2

What is $\begin{pmatrix} 1 & 2 \\ 4 & 5 \\ 7 & 8 \\ 10 & 11 \end{pmatrix} \begin{pmatrix} k_1 & l_1 & m_1 \\ k_2 & l_2 & m_2 \end{pmatrix}$?

ANSWER

$$\begin{pmatrix} 1 & 2 \\ 4 & 5 \\ 7 & 8 \\ 10 & 11 \end{pmatrix} \begin{pmatrix} k_1 \\ k_2 \end{pmatrix} = \begin{pmatrix} k_1 + 2k_2 \\ 4k_1 + 5k_2 \\ 7k_1 + 8k_2 \\ 10k_1 + 11k_2 \end{pmatrix}$$

Multiply the first column of the second matrix by the respective rows of the first matrix.

$$\begin{pmatrix} 1 & 2 \\ 4 & 5 \\ 7 & 8 \\ 10 & 11 \end{pmatrix} \begin{pmatrix} l_1 \\ l_2 \end{pmatrix} = \begin{pmatrix} l_1 + 2l_2 \\ 4l_1 + 5l_2 \\ 7l_1 + 8l_2 \\ 10l_1 + 11l_2 \end{pmatrix}$$

Do the same with the second column.

$$\begin{pmatrix} 1 & 2 \\ 4 & 5 \\ 7 & 8 \\ 10 & 11 \end{pmatrix} \begin{pmatrix} m_1 \\ m_2 \end{pmatrix} = \begin{pmatrix} m_1 + 2m_2 \\ 4m_1 + 5m_2 \\ 7m_1 + 8m_2 \\ 10m_1 + 11m_2 \end{pmatrix}$$

And the third column.

The final answer is just a concatenation of the three answers above.

$$\begin{pmatrix} k_1 + 2k_2 & l_1 + 2l_2 & m_1 + 2m_2 \\ 4k_1 + 5k_2 & 4l_1 + 5l_2 & 4m_1 + 5m_2 \\ 7k_1 + 8k_2 & 7l_1 + 8l_2 & 7m_1 + 8m_2 \\ 10k_1 + 11k_2 & 10l_1 + 11l_2 & 10m_1 + 11m_2 \end{pmatrix}$$

THE RULES OF MATRIX MULTIPLICATION

WHEN MULTIPLYING MATRICES, THERE ARE THREE THINGS TO REMEMBER:

- THE NUMBER OF COLUMNS IN THE FIRST MATRIX MUST EQUAL THE NUMBER OF ROWS IN THE SECOND MATRIX.
- THE RESULT MATRIX WILL HAVE A NUMBER OF ROWS EQUAL TO THE FIRST MATRIX.
- THE RESULT MATRIX WILL HAVE A NUMBER OF COLUMNS EQUAL TO THE SECOND MATRIX.



Can the following pairs of matrices can be multiplied?

If so, how many rows and columns will the resulting matrix have?

EXAMPLE PROBLEM 1

$$\begin{pmatrix} 2 & 3 & 4 \\ -5 & 3 & 6 \end{pmatrix} \begin{pmatrix} 2 \\ -7 \\ 0 \end{pmatrix}$$

ANSWER

Yes! The resulting matrix will have 2 rows and 1 column:

$$\begin{pmatrix} 2 & 3 & 4 \\ -5 & 3 & 6 \end{pmatrix} \begin{pmatrix} 2 \\ -7 \\ 0 \end{pmatrix} = \begin{pmatrix} 2 \times 2 + 3 \times (-7) + 4 \times 0 \\ (-5) \times 2 + 3 \times (-7) + 6 \times 0 \end{pmatrix} = \begin{pmatrix} -17 \\ -31 \end{pmatrix}$$

EXAMPLE PROBLEM 2

$$\begin{pmatrix} 9 & 4 & -1 \\ 7 & -6 & 0 \\ -5 & 3 & 8 \end{pmatrix} \begin{pmatrix} 2 & -2 & 1 \\ 4 & 9 & -7 \end{pmatrix}$$

ANSWER

No. The number of columns in the first matrix is 3, but the number of rows in the second matrix is 2. These matrices cannot be multiplied.

IDENTITY AND INVERSE MATRICES

THE LAST THINGS I'M GOING TO EXPLAIN TONIGHT ARE *IDENTITY MATRICES* AND *INVERSE MATRICES*.

AN *IDENTITY MATRIX* IS A SQUARE MATRIX WITH ONES ACROSS THE DIAGONAL, FROM TOP LEFT TO BOTTOM RIGHT, AND ZEROS EVERYWHERE ELSE.

HERE IS A 2×2 *IDENTITY MATRIX*:

$$\begin{pmatrix} 1 & 0 \\ 0 & 1 \end{pmatrix}$$

AND HERE IS A 3×3 *IDENTITY MATRIX*:

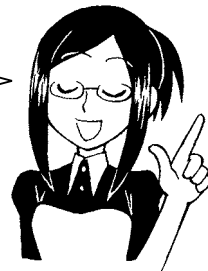
$$\begin{pmatrix} 1 & 0 & 0 \\ 0 & 1 & 0 \\ 0 & 0 & 1 \end{pmatrix}$$

Some square matrices (a matrix that has the same number of rows as columns) are *invertible*. A square matrix multiplied by its inverse will equal an identity matrix of the same size and shape, so it's easy to demonstrate that one matrix is the inverse of another.

For example:

$$\begin{pmatrix} 1 & 2 \\ 3 & 4 \end{pmatrix} \begin{pmatrix} -2 & 1 \\ 1.5 & -0.5 \end{pmatrix} = \begin{pmatrix} 1 \times (-2) + 2 \times 1.5 & 1 \times 1 + 2 \times (-0.5) \\ 3 \times (-2) + 4 \times 1.5 & 3 \times 1 + 4 \times (-0.5) \end{pmatrix} = \begin{pmatrix} 1 & 0 \\ 0 & 1 \end{pmatrix}$$

So $\begin{pmatrix} -2 & 1 \\ 1.5 & -0.5 \end{pmatrix}$ is the inverse of $\begin{pmatrix} 1 & 2 \\ 3 & 4 \end{pmatrix}$.

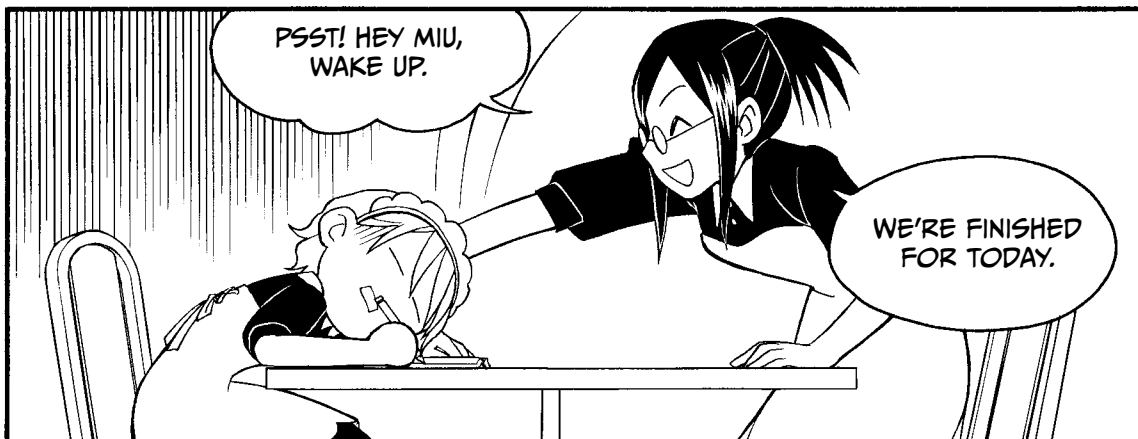

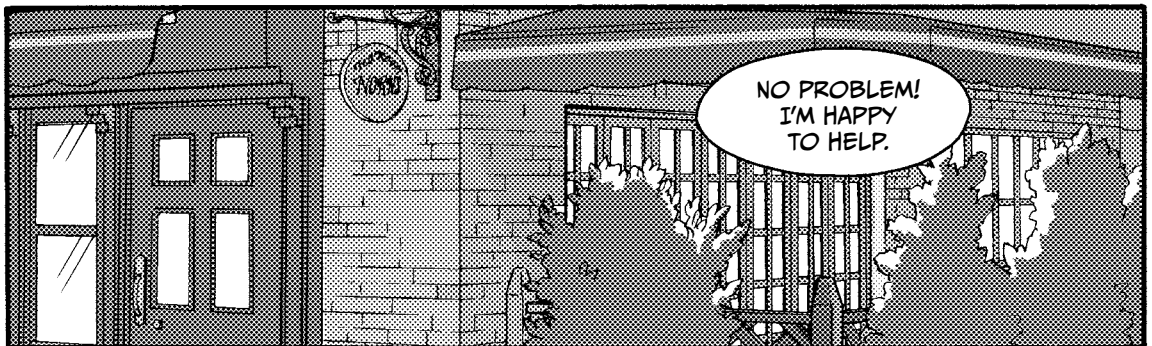
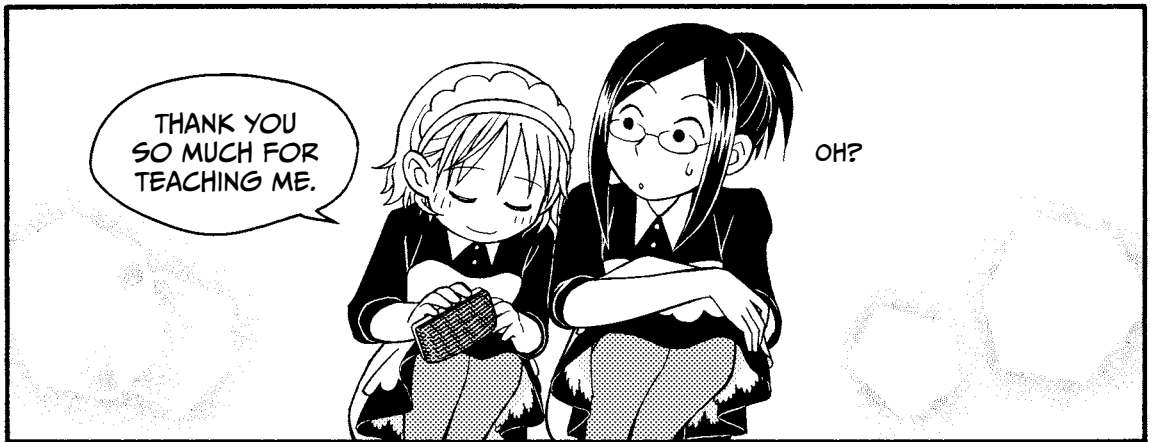
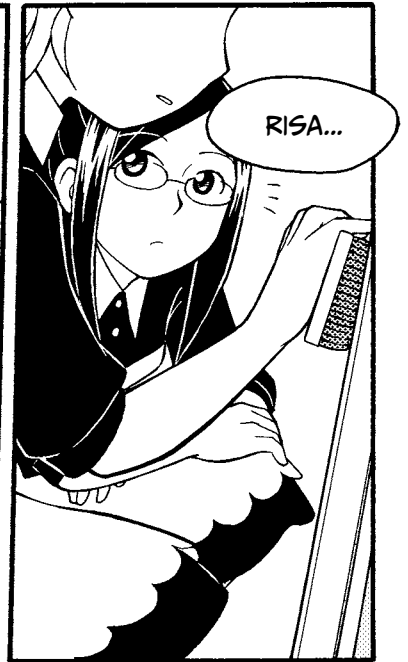
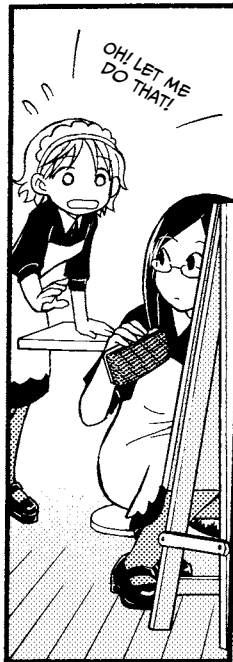
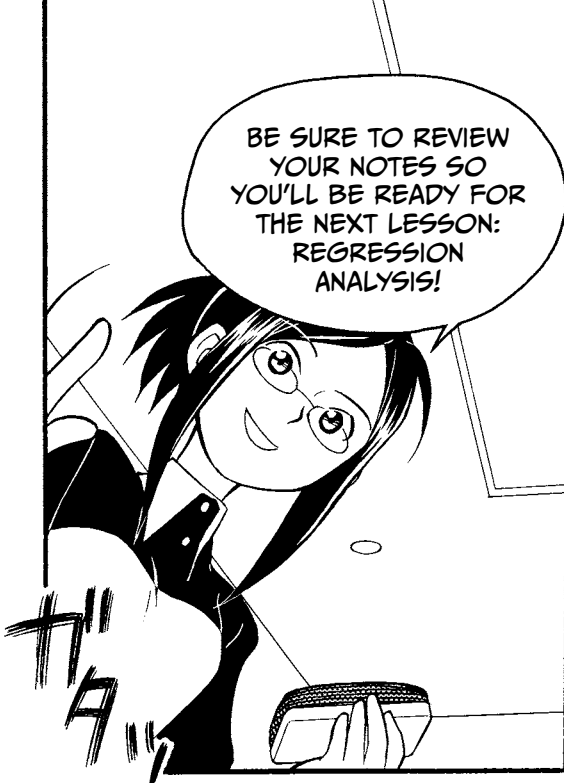

STATISTICAL DATA TYPES

Now that you've had a little general math refresher, it's time for a refreshing chaser of *statistics*, a branch of mathematics that deals with the interpretation and analysis of data. Let's dive right in.

We can categorize data into two types. Data that can be measured with numbers is called *numerical data*, and data that cannot be measured is called *categorical data*. Numerical data is sometimes called *quantitative data*, and categorical data is sometimes called *qualitative data*. These names are subjective and vary based on the field and the analyst. Table 1-1 shows examples of numerical and categorical data.

TABLE 1-1: NUMERICAL VS. CATEGORICAL DATA

	Number of books read per month	Age (in years)	Place where person most often reads	Gender
Person A	4	20	Train	Female
Person B	2	19	Home	Male
Person C	10	18	Café	Male
Person D	14	22	Library	Female

Number of books read per month and *Age* are both examples of numerical data, while *Place where person most often reads* and *Gender* are not typically represented by numbers. However, categorical data can be converted into numerical data, and vice versa. Table 1-2 gives an example of how numerical data can be converted to categorical.

TABLE 1-2: CONVERTING NUMERICAL DATA TO CATEGORICAL DATA

	Number of books read per month		Number of books read per month
Person A	4	➔	Few
Person B	2		Few
Person C	10		Many
Person D	14		Many

In this conversion, the analyst has converted the values 1 to 5 into the category *Few*, values 6 to 9 into the category *Average*, and values 10 and higher into the category *Many*. The ranges are up to the discretion of the researcher. Note that these three categories (Few, Average, Many) are *ordinal*, meaning that they can be ranked in order: Many is more than Average is more than Few. Some categories cannot be easily ordered. For instance, how would one easily order the categories Brown, Purple, Green?

Table 1-3 provides an example of how categorical data can be converted to numerical data.

TABLE 1-3: CONVERTING CATEGORICAL DATA TO NUMERICAL DATA

Favorite season		Spring	Summer	Autumn	Winter
Person A	Spring	1	0	0	0
Person B	Summer	0	1	0	0
Person C	Autumn	0	0	1	0
Person D	Winter	0	0	0	1

In this case, we have converted the categorical data *Favorite season*, which has four categories (Spring, Summer, Autumn, Winter), into binary data in four columns. The data is described as binary because it takes on one of two values: *Favorite* is represented by 1 and *Not Favorite* is represented by 0.

It is also possible to represent this data with three columns. Why can we omit one column? Because we know each respondent's favorite season even if a column is omitted. For example, if the first three columns (Spring, Summer, Autumn) are 0, you know Winter must be 1, even if it isn't shown.

In multiple regression analysis, we need to ensure that our data is *linearly independent*; that is, no set of J columns shown can be used to exactly infer the content of another column within that set. Ensuring linear independence is often done by deleting the last column of data. Because the following statement is true, we can delete the Winter column from Table 1-3:

$$(\text{Winter}) = 1 - (\text{Spring}) - (\text{Summer}) - (\text{Autumn})$$

In regression analysis, we must be careful to recognize which variables are numerical, ordinal, and categorical so we use the variables correctly.

HYPOTHESIS TESTING

Statistical methods are often used to test scientific hypotheses. A *hypothesis* is a proposed statement about the relationship between variables or the properties of a single variable, describing a phenomenon or concept. We collect data and use hypothesis testing to decide whether our hypothesis is supported by the data.

We set up a hypothesis test by stating not one but two hypotheses, called the *null hypothesis* (H_0) and the *alternative hypothesis* (H_a). The null hypothesis is the default hypothesis we wish to disprove, usually stating that there is a specific relationship (or none at all) between variables or the properties of a single variable. The alternative hypothesis is the hypothesis we are trying to prove. If our data differs enough from what we would expect if the null hypothesis were true, we can reject the null and accept the alternative hypothesis. Let's consider a very simple example, with the following hypotheses:

H_0 : Children order on average 10 cups of hot chocolate per month.

H_a : Children do not order on average 10 cups of hot chocolate per month.

We're proposing statements about a single variable—the number of hot chocolates ordered per month—and checking if it has a certain property: having an average of 10. Suppose we observed five children for a month and found that they ordered 7, 9, 10, 11, and 13 cups of hot chocolate, respectively. We assume these five children are a representative *sample* of the total *population* of all hot chocolate-drinking children. The average of these five children's orders is 10. In this case, we cannot prove that the null hypothesis is false, since the value proposed in our null hypothesis (10) is indeed the average of this sample.

However, suppose we observed a sample of five different children for a month and they ordered 29, 30, 31, 32, and 35 cups of hot chocolate, respectively. The average of these five children's orders is 31.4; in fact, not a single child came anywhere close to drinking only 10 cups of hot chocolate. On the basis of this data, we would assert that we should reject the null hypothesis.

In this example, we've stated hypotheses about a single variable: the number of cups each child orders per month. But when we're looking at the relationship between two or more variables, as we do in regression analysis, our null hypothesis usually states that there is no relationship between the variables being tested, and the alternative hypothesis states that there is a relationship.

MEASURING VARIATION

Suppose Miu and Risa had a karaoke competition with some friends from school. They competed in two teams of five. Table 1-4 shows how they scored.

TABLE 1-4: KARAOKE SCORES FOR TEAM MIU AND TEAM RISA

Team member	Score	Team member	Score
Miu	48	Risa	67
Yuko	32	Asuka	55
Aiko	88	Nana	61
Maya	61	Yuki	63
Marie	71	Rika	54
Average	60	Average	60

There are multiple statistics we can use to describe the “center” of a data set. Table 1-4 shows the average of the data for each team, also known as the *mean*. This is calculated by adding the scores of each member of the group and dividing by the number of members in the group. Each of the karaoke groups has a mean score of 60.

We could also define the center of these data sets as being the middle number of each group when the scores are put in order. This is the *median* of the data. To find the median, write the scores in increasing order (for Team Miu, this is 32, 48, 61, 71, 88) and the median is the number in the middle of this list. For Team Miu, the median is Maya’s score of 61. The median happens to be 61 for Team Risa as well, with Nana having the median score on this team. If there were an even number of members on each team, we would usually take the mean of the two middle scores.

So far, the statistics we’ve calculated seem to indicate that the two sets of scores are the same. But what do you notice when we put the scores on a number line (see Figure 1-1)?

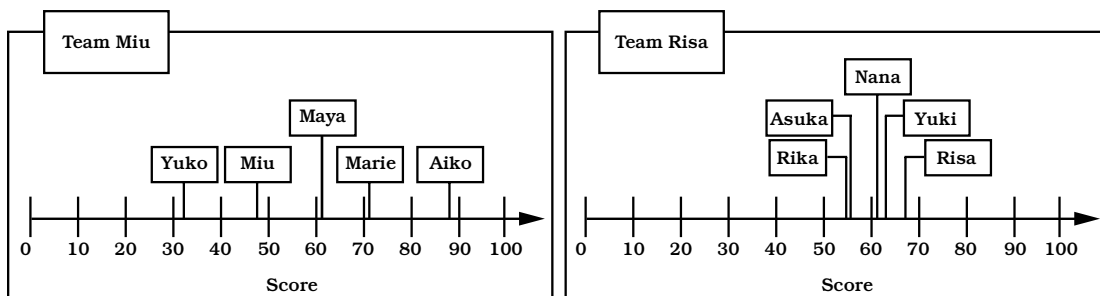

FIGURE 1-1: KARAOKE SCORES FOR TEAM MIU AND TEAM RISA ON NUMBER LINES

Team Miu's scores are much more spread out than Team Risa's. Thus, we say that the data sets have different *variation*.

There are several ways to measure variation, including the sum of squared deviations, variance, and standard deviation. Each of these measures share the following characteristics:

- All of them measure the spread of the data from the mean.
- The greater the variation in the data, the greater the value of the measure.
- The minimum value of the measures is zero—that happens only if your data doesn't vary at all!

SUM OF SQUARED DEVIATIONS

The *sum of squared deviations* is a measure often used during regression analysis. It is calculated as follows:

sum of (individual score – mean score)²,

which is written mathematically as

$$\sum (x - \bar{x})^2.$$

The sum of squared deviations is not often used on its own to describe variation because it has a fatal shortcoming—its value increases as the number of data points increases. As you have more and more numbers, the sum of their differences from the mean gets bigger and bigger.

VARIANCE

This shortcoming is alleviated by calculating the *variance*:

$$\frac{\sum (x - \bar{x})^2}{n - 1}, \text{ where } n = \text{the number of data points.}$$

This calculation is also called the *unbiased sample variance*, because the denominator is the number of data points minus 1 rather than simply the number of data points. In research studies that use data from samples, we usually subtract 1 from the number of data points to adjust for the fact that we are using a sample of the population, rather than the entire population. This increases the variance.

This reduced denominator is called the *degrees of freedom*, because it represents the number of values that are free to vary. For practical purposes, it is the number of cases (for example, observations or groups) minus 1. So if we were looking at Team Miu and

Team Risa as samples of the entire karaoke-singing population, we'd say there were 4 degrees of freedom when calculating their statistics, since there are five members on each team. We subtract 1 from the number of singers because they are just a sample of all possible singers in the world and we want to overestimate the variance among them.

The units of the variance are not the same as the units of the observed data. Instead, variance is expressed in units squared, in this case "points squared."

STANDARD DEVIATION

Like variance, the *standard deviation* shows whether all the data points are clustered together or spread out. The standard deviation is actually just the square root of the variance:

$$\sqrt{\text{variance}}$$

Researchers usually use standard deviation as the measure of variation because the units of the standard deviation are the same as those of the original data. For our karaoke singers, the standard deviation is reported in "points."

Let's calculate the sum of squared deviations, variance, and standard deviation for Team Miu (see Table 1-5).

TABLE 1-5: MEASURING VARIATION OF SCORES FOR TEAM MIU

Measure of variation	Calculation
Sum of squared deviations	$(48 - 60)^2 + (32 - 60)^2 + (88 - 60)^2 + (61 - 60)^2 + (71 - 60)^2$ $= (-12)^2 + (-28)^2 + 28^2 + 1^2 + 11^2$ $= 1834$
Variance	$\frac{1834}{5 - 1} = 458.5$
Standard deviation	$\sqrt{458.5} = 21.4$

Now let's do the same for Team Risa (see Table 1-6).

TABLE 1-6: MEASURING VARIATION OF SCORES FOR TEAM RISA

Measure of variation	Calculation
Sum of squared deviations	$(67 - 60)^2 + (55 - 60)^2 + (61 - 60)^2 + (63 - 60)^2 + (54 - 60)^2$ $= 7^2 + (-5)^2 + 1^2 + 3^2 + (-6)^2$ $= 120$
Variance	$\frac{120}{5 - 1} = 30$
Standard deviation	$\sqrt{30} = 5.5$

We see that Team Risa’s standard deviation is 5.5 points, whereas Team Miu’s is 21.4 points. Team Risa’s karaoke scores vary less than Team Miu’s, so Team Risa has more consistent karaoke performers.

PROBABILITY DENSITY FUNCTIONS

We use probability to model events that we cannot predict with certainty. Although we can accurately predict many future events—such as whether running out of gas will cause a car to stop running or how much rocket fuel it would take to get to Mars—many physical, chemical, biological, social, and strategic problems are so complex that we cannot hope to know all of the variables and forces that affect the outcome.

A simple example is the flipping of a coin. We do not know all of the physical forces involved in a single coin flip—temperature, torque, spin, landing surface, and so on. However, we expect that over the course of many flips, the variance in all these factors will cancel out, and we will observe an equal number of heads and tails. Table 1-5 shows the results of flipping a billion quarters in number of flips and percentage of flips.

TABLE 1-5: TALLY OF A BILLION COIN FLIPS

	Number of flips	Percentage of flips
Heads	499,993,945	49.99939%
Tails	500,006,054	50.00061%
Stands on its edge	1	0.000001%

As we might have guessed, the percentages of heads and tails are both very close to 50%. We can summarize what we know about coin flips in a probability density function, $P(x)$, which we can apply to any given coin flip, as shown here:

$$P(\text{Heads}) = .5, P(\text{Tails}) = .5, P(\text{Stands on its edge}) < 1 \times 10^{-9}$$

But what if we are playing with a cheater? Perhaps someone has weighted the coin so that $P(x)$ is now this:

$$P(\text{Heads}) = .3, P(\text{Tails}) = .7, P(\text{Stands on its edge}) = 0$$

What do we expect to happen on a single flip? Will it always be tails? What will the average be after a billion flips?

Not all events have so few possibilities as these coin examples. We often wish to model data that can be continuously measured. For example, height is a continuous measurement. We could measure your height down to the nearest meter, centimeter, millimeter, or . . . nanometer. As we begin dealing with data where the possibilities lie on a continuous space, we need to use continuous functions to represent the probability of events.

A *probability density function* allows us to compute the probability that the data lies within a given range of values. We can plot a probability density function as a curve, where the x-axis represents the *event space*, or the possible values the result can take, and the y-axis is $f(x)$, or the probability density function value of x . The area under the curve between two possible values represents the probability of getting a result between those two values.

NORMAL DISTRIBUTIONS

One important probability density function is the *normal distribution* (see Figure 1-2), also called the *bell curve* because of its symmetrical shape, which researchers use to model many events.

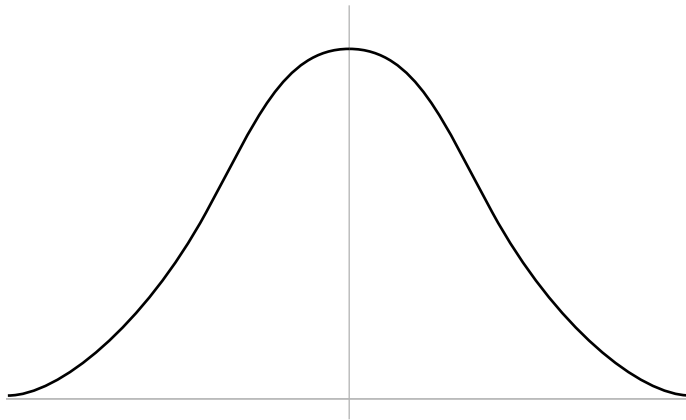

FIGURE 1-2: A NORMAL DISTRIBUTION

The standard normal distribution probability density function can be expressed as follows:

$$f(x) = \frac{1}{\sqrt{2\pi}} e^{-\frac{x^2}{2}}$$

The mean of the standard normal distribution function is zero. When we plot the function, its peak or *maximum* is at the mean and thus at zero. The tails of the distribution fall symmetrically on either side of the mean in a bell shape and extend to infinity, approaching, but never quite touching, the x-axis. The standard normal distribution has a standard deviation of 1. Because the mean is zero and the standard deviation is 1, this distribution is also written as $N(0,1)$.

The area under the curve is equal to 1 (100%), since the value will definitely fall somewhere beneath the curve. The further from the mean a value is, the less probable that value is, as represented by the diminishing height of the curve. You may have seen a curve like this describing the distribution of test scores. Most test takers have a score that is close to the mean. A few people score exceptionally high, and a few people score very low.

CHI-SQUARED DISTRIBUTIONS

Not all data is best modeled by a normal distribution. The *chi-squared* (χ^2) *distribution* is a probability density function that fits the distribution of the sum of squares. That means chi-squared distributions can be used to estimate variation. The chi-squared probability density function is shown here:

$$f(x) = \begin{cases} \frac{1}{2^{\frac{k}{2}} \int_0^{\infty} x^{\frac{k}{2}-1} e^{-x} dx} \times x^{\frac{k}{2}-1} \times e^{-\frac{x}{2}} & , x > 0 \\ 0, & x \leq 0 \end{cases}$$

The sum of squares can never be negative, and we see that $f(x)$ is exactly zero for negative numbers. When the probability density function of x is the one shown above, we say, “ x follows a chi-squared distribution with k degree(s) of freedom.”

The chi-squared distribution is related to the standard normal distribution. In fact, if you take Z_1, Z_2, \dots, Z_k , as a set of independent, identically distributed standard normal random variables and then take the sum of squares of these variables like this,

$$X = Z_1^2 + Z_2^2 + \dots + Z_k^2,$$

then X is a chi-squared random variable with k degrees of freedom. Thus, we will use the chi-squared distribution of k to represent sums of squares of a set of k normal random variables.

In Figure 1-3, we plot two chi-squared density curves, one for $k = 2$ degrees of freedom and another for $k = 10$ degrees of freedom.

When $k = 2$

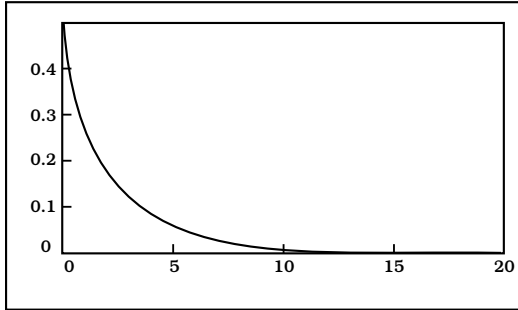

When $k = 10$

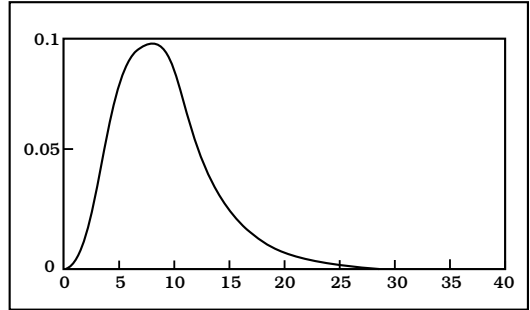

FIGURE 1-3: CHI-SQUARED DENSITY CURVES FOR 2 DEGREES OF FREEDOM (LEFT) AND 10 DEGREES OF FREEDOM (RIGHT)

Notice the differences. What is the limit of the density functions as x goes to infinity? Where is the peak of the functions?

PROBABILITY DENSITY DISTRIBUTION TABLES

Let's say we have a data set with a variable X that follows a chi-squared distribution, with 5 degrees of freedom. If we wanted to know for some point x whether the probability P of $X > x$ is less than a target probability—also known as the *critical value* of the statistic—we must integrate a density curve to calculate that probability. By *integrate*, we mean find the area under the relevant portion of the curve, illustrated in Figure 1-4.

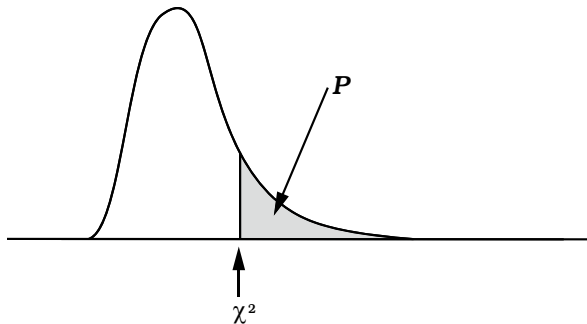

FIGURE 1-4: THE PROBABILITY P THAT A VALUE X EXCEEDS THE CRITICAL CHI-SQUARED VALUE x

Since that is cumbersome to do by hand, we use a computer or, if one is unavailable, a distribution table we find in a book. Distribution tables summarize features of a density curve in many ways. In the case of the chi-squared distribution, the distribution table gives us the point x such that the probability that $X > x$ is equal to a probability P . Statisticians often choose $P = .05$, meaning there is only a 5% chance that a randomly selected value of X will be greater than x . The value of P is known as a p -value.

We use a chi-squared probability distribution table (Table 1-6) to see where our degrees of freedom and our p -value intersect. This number gives us the value of χ^2 (our test statistic). The probability of a chi-squared of this magnitude is equal to or less than the p at the top of the column.

TABLE 1-6: CHI-SQUARED PROBABILITY DISTRIBUTION TABLE

p degrees of freedom	.995	.99	.975	.95	.05	.025	.01	.005
1	0.000039	0.0002	0.0010	0.0039	3.8415	5.0239	6.6349	7.8794
2	0.0100	0.0201	0.0506	0.1026	5.9915	7.3778	9.2104	10.5965
3	0.0717	0.1148	0.2158	0.3518	7.8147	9.3484	11.3449	12.8381
4	0.2070	0.2971	0.4844	0.7107	9.4877	11.1433	13.2767	14.8602
5	0.4118	0.5543	0.8312	1.1455	11.0705	12.8325	15.0863	16.7496
6	0.6757	0.8721	1.2373	1.6354	12.5916	14.4494	16.8119	18.5475
7	0.9893	1.2390	1.6899	2.1673	14.0671	16.0128	18.4753	20.2777
8	1.3444	1.6465	2.1797	2.7326	15.5073	17.5345	20.0902	21.9549
9	1.7349	2.0879	2.7004	3.3251	16.9190	19.0228	21.6660	23.5893
10	2.1558	2.5582	3.2470	3.9403	18.3070	20.4832	23.2093	25.1881

To read this table, identify the k degrees of freedom in the first column to determine which row to use. Then select a value for p . For instance, if we selected $p = .05$ and had degrees of freedom $k = 5$, then we would find where the the fifth column and the fifth row intersect (highlighted in Table 1-6). We see that $x = 11.0705$. This means that for a chi-squared random variable and 5 degrees of freedom, the probability of getting a draw $X = 11.0705$ or greater is $.05$. In other words, the area under the curve corresponding to chi-squared values of 11.0705 or greater is equal to 11% of the total area under the curve.

If we observed a chi-squared random variable with 5 degrees of freedom to have a value of 6.1, is the probability more or less than $.05$?

F DISTRIBUTIONS

The F distribution is just a ratio of two separate chi-squared distributions, and it is used to compare the variance of two samples. As a result, it has two different degrees of freedom, one for each sample.

This is the probability density function of an F distribution:

$$f(x) = \begin{cases} \frac{\left(\int_0^\infty x^{\frac{v_1+v_2-1}{2}} e^{-x} dx \right) \times (v_1)^{\frac{v_1}{2}} \times (v_2)^{\frac{v_2}{2}}}{\left(\int_0^\infty x^{\frac{v_1-1}{2}} e^{-x} dx \right) \times \left(\int_0^\infty x^{\frac{v_2-1}{2}} e^{-x} dx \right)} \times \frac{x^{\frac{v_1}{2}-1}}{(v_1 \times x + v_2)^{\frac{v_1+v_2}{2}}}, & x > 0 \\ 0, & x \leq 0 \end{cases}$$

If the probability density function of X is the one shown above, in statistics, we say, “ X follows an F distribution with degrees of freedom v_1 and v_2 .”

When $v_1 = 5$ and $v_2 = 10$ and when $v_1 = 10$ and $v_2 = 5$, we get slightly different curves, as shown in Figure 1-5.

When $v_1 = 5$ and $v_2 = 10$

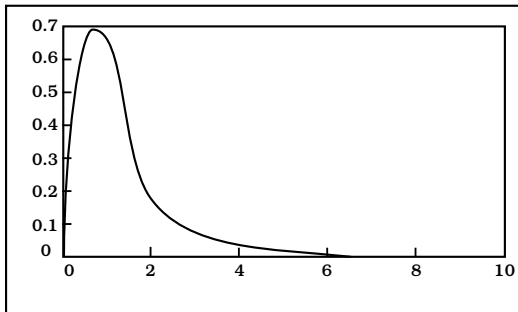

When $v_1 = 10$ and $v_2 = 5$

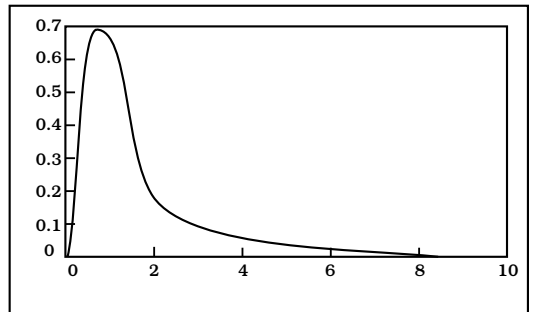

FIGURE 1-5: F DISTRIBUTION DENSITY CURVES FOR 5 AND 10 RESPECTIVE DEGREES OF FREEDOM (LEFT) AND 10 AND 5 RESPECTIVE DEGREES OF FREEDOM (RIGHT)

Figure 1-6 shows a graph of an F distribution with degrees of freedom v_1 and v_2 . This shows the F value as a point on the horizontal axis, and the total area of the shaded part to the right is the probability P that a variable with an F distribution has a value greater than the selected F value.

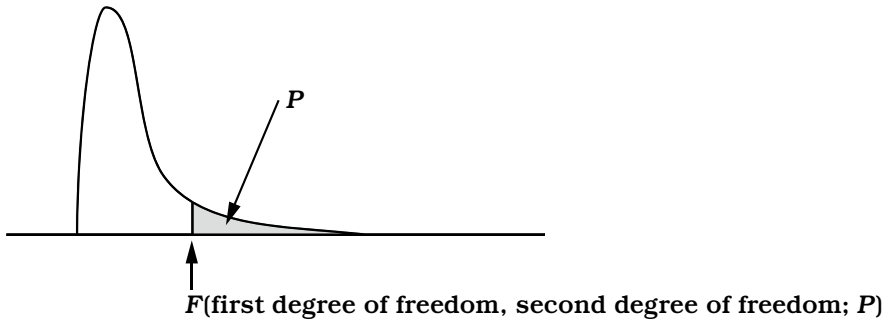

FIGURE 1-6: THE PROBABILITY P THAT A VALUE x EXCEEDS THE CRITICAL F VALUE

Table 1-7 shows the F distribution table when $p = .05$.

TABLE 1-7: F PROBABILITY DISTRIBUTION TABLE FOR $p = .05$

$v_1 \backslash v_2$	1	2	3	4	5	6	7	8	9	10
1	161.4	199.5	215.7	224.6	230.2	264.0	236.8	238.9	240.5	241.9
2	18.5	19.0	19.2	19.2	19.3	19.3	19.4	19.4	19.4	19.4
3	10.1	9.6	9.3	9.1	9.0	8.9	8.9	8.8	8.8	8.8
4	7.7	6.9	6.6	6.4	6.3	6.2	6.1	6.0	6.0	6.0
5	6.6	5.8	5.4	5.2	5.1	5.0	4.9	4.8	4.8	4.7
6	6.0	5.1	4.8	4.5	4.4	4.3	4.2	4.1	4.1	4.1
7	5.6	4.7	4.3	4.1	4.0	3.9	3.8	3.7	3.7	3.6
8	5.3	4.5	4.1	3.8	3.7	3.6	3.5	3.4	3.4	3.3
9	5.1	4.3	3.9	3.6	3.5	3.4	3.3	3.2	3.2	3.1
10	5.0	4.1	3.7	3.5	3.3	3.2	3.1	3.1	3.0	3.0
11	4.8	4.0	3.6	3.4	3.2	3.1	3.1	2.9	2.9	2.9
12	4.7	3.9	3.5	3.3	3.1	3.0	2.9	2.8	2.8	2.8

Using an F distribution table is similar to using a chi-squared distribution table, only this time the column headings across the top give the degrees of freedom for one sample and the row labels give the degrees of freedom for the other sample. A separate table is used for each common p -value.

In Table 1-7, when $v_1 = 1$ and $v_2 = 12$, the critical value is 4.7. This means that when we perform a statistical test, we calculate our test statistic and compare it to the critical value of 4.7 from this table; if our calculated test statistic is greater than 4.7, our result is considered *statistically significant*. In this table, for any test statistic greater than the number in the table, the p -value is less than .05. This means that when $v_1 = 1$ and $v_2 = 12$, the probability of an F statistic of 4.7 or higher occurring when your null hypothesis is true is 5%, so there's only a 5% chance of rejecting the null hypothesis when it is actually true.

Let's look at another example. Table 1-8 shows the F distribution table when $p = .01$.

TABLE 1-8: F PROBABILITY DISTRIBUTION TABLE FOR $p = .01$

$v_2 \backslash v_1$	1	2	3	4	5	6	7	8	9	10
1	4052.2	4999.3	5403.5	5624.3	5764.0	5859.0	5928.3	5981.0	6022.4	6055.9
2	98.5	99.0	99.2	99.3	99.3	99.3	99.4	99.4	99.4	99.4
3	34.1	30.8	29.5	28.7	28.2	27.9	27.7	27.5	27.3	27.2
4	21.2	18.8	16.7	16.0	15.5	15.2	15.0	14.8	14.7	14.5
5	16.3	13.3	12.1	11.4	11.0	10.7	10.5	10.3	10.2	10.1
6	13.7	10.9	9.8	9.1	8.7	8.5	8.3	8.1	8.0	7.9
7	12.2	9.5	8.5	7.8	7.5	7.2	7.0	6.8	6.7	6.6
8	11.3	8.6	7.6	7.0	6.6	6.4	6.2	6.0	5.9	5.8
9	10.6	8.0	7.0	6.4	6.1	5.8	5.6	5.5	5.4	5.6
10	10.0	7.6	6.6	6.0	5.6	5.4	5.2	5.1	4.9	4.8
11	9.6	7.2	6.2	5.7	5.3	5.1	4.9	4.7	4.6	4.5
12	9.3	6.9	6.0	5.4	5.1	4.8	4.6	4.5	4.4	4.3

Now when $v_1 = 1$ and $v_2 = 12$, the critical value is 9.3. The probability that a sample statistic as large or larger than 9.3 would occur if your null hypothesis is true is only .01. Thus, there is a very small probability that you would incorrectly reject the null hypothesis. Notice that when $p = .01$, the critical value is larger than when $p = .05$. For constant v_1 and v_2 , as the p -value goes down, the critical value goes up.

2

SIMPLE REGRESSION ANALYSIS

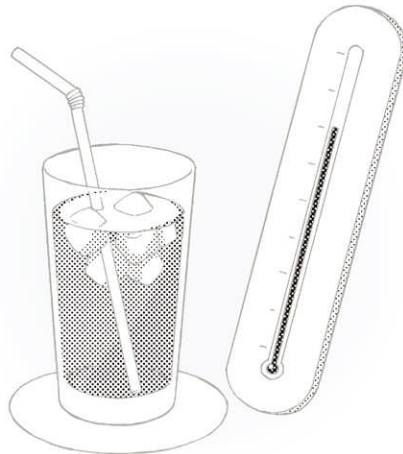

FIRST STEPS

THAT MEANS...

THERE IS A CONNECTION BETWEEN THE TWO, RIGHT?

EXACTLY!

WHERE DID YOU LEARN SO MUCH ABOUT REGRESSION ANALYSIS, MIU?

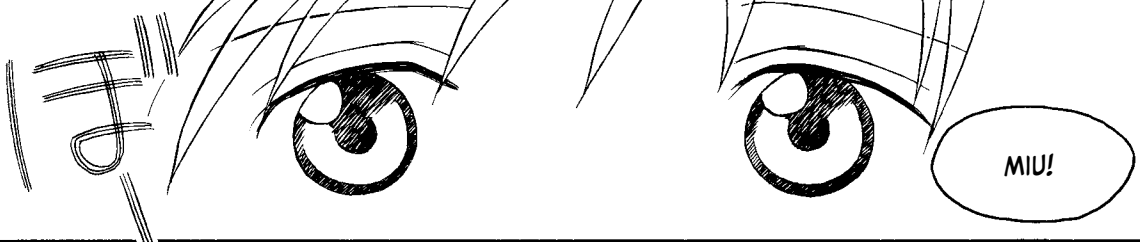
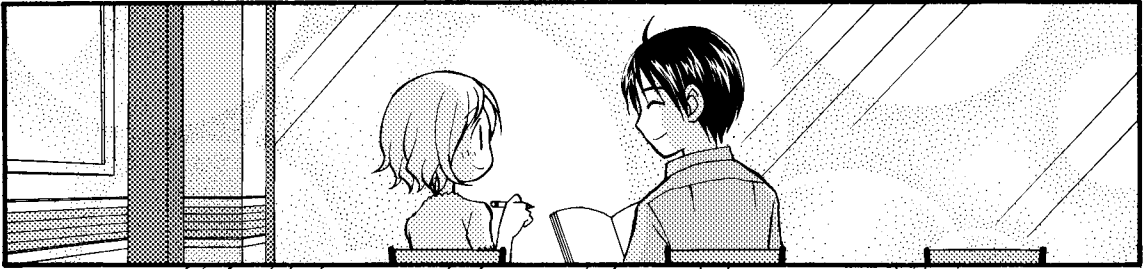

MIU!

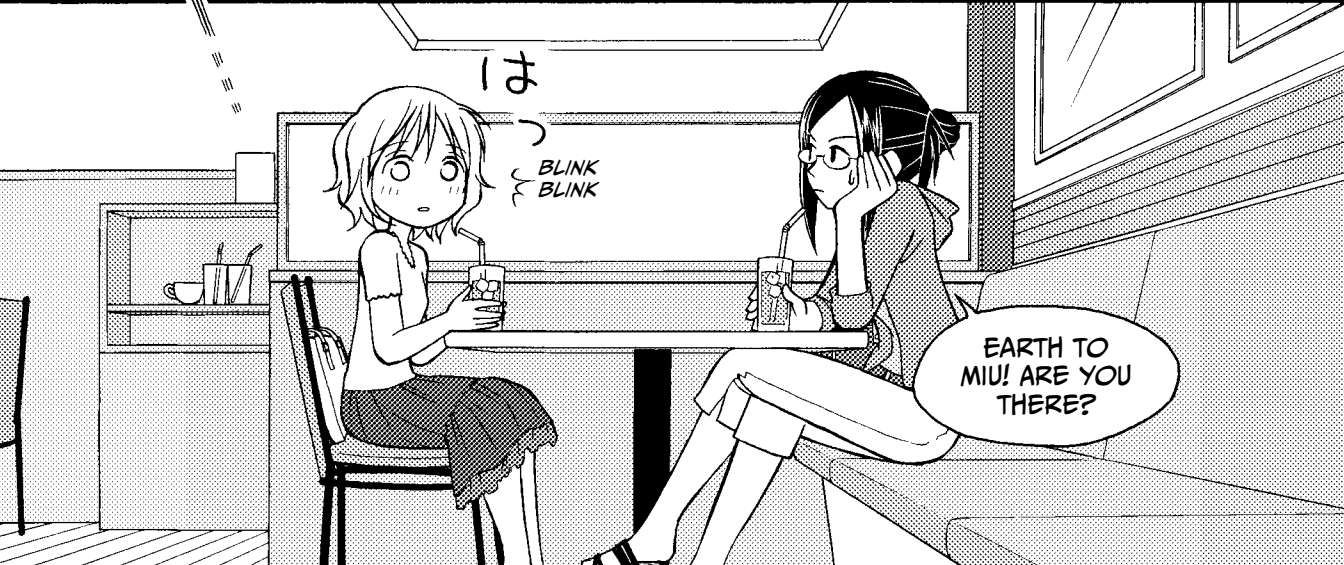

EARTH TO MIU! ARE YOU THERE?

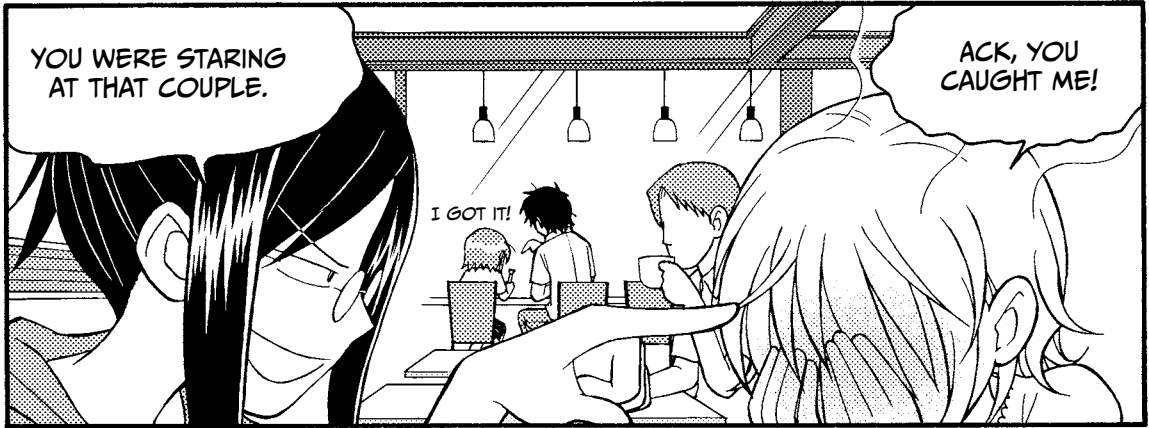

YOU WERE STARING AT THAT COUPLE.

ACK, YOU CAUGHT ME!

I GOT IT!

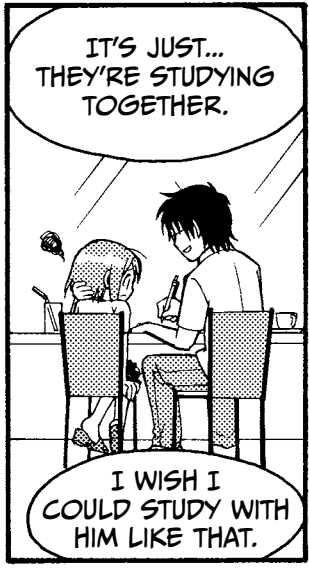

IT'S JUST... THEY'RE STUDYING TOGETHER.

I WISH I COULD STUDY WITH HIM LIKE THAT.

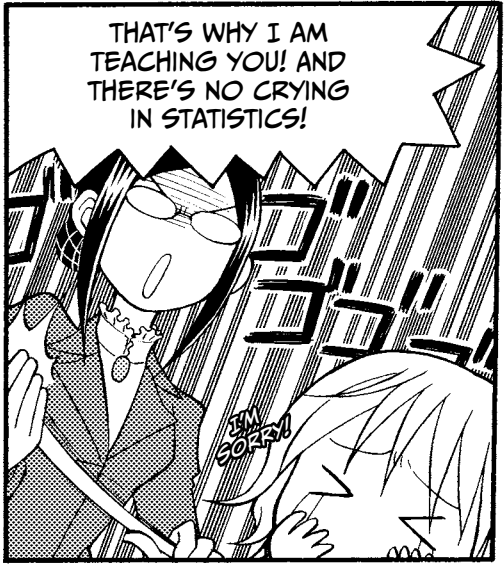

THAT'S WHY I AM TEACHING YOU! AND THERE'S NO CRYING IN STATISTICS!

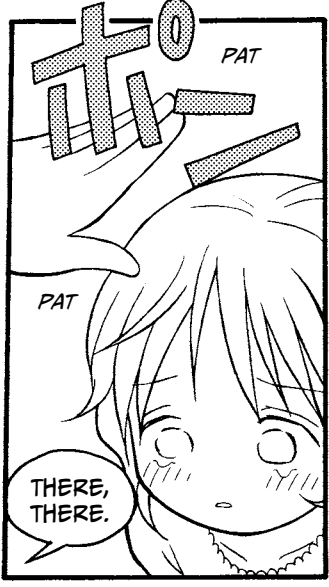

THERE, THERE.

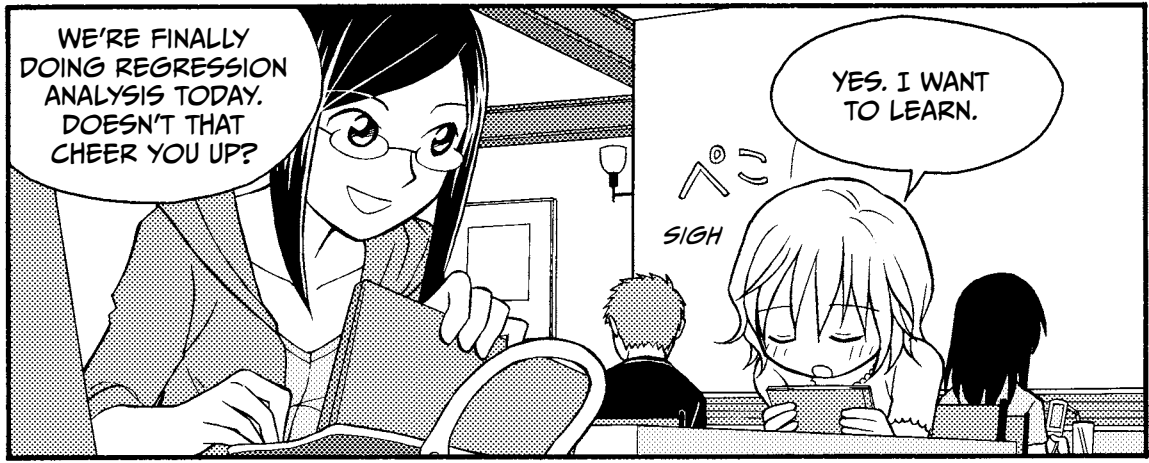

WE'RE FINALLY DOING REGRESSION ANALYSIS TODAY. DOESN'T THAT CHEER YOU UP?

YES. I WANT TO LEARN.

SIGH

ALL RIGHT THEN, LET'S GO! THIS TABLE SHOWS THE HIGH TEMPERATURE AND THE NUMBER OF ICED TEA ORDERS EVERY DAY FOR TWO WEEKS.

	High temp. (°C)	Iced tea orders
22nd (Mon.)	29	77
23rd (Tues.)	28	62
24th (Wed.)	34	93
25th (Thurs.)	31	84
26th (Fri.)	25	59
27th (Sat.)	29	64
28th (Sun.)	32	80
29th (Mon.)	31	75
30th (Tues.)	24	58
31st (Wed.)	33	91
1st (Thurs.)	25	51
2nd (Fri.)	31	73
3rd (Sat.)	26	65
4th (Sun.)	30	84

PLOTTING THE DATA

NOW...

...WE'LL FIRST MAKE THIS INTO A SCATTER PLOT...

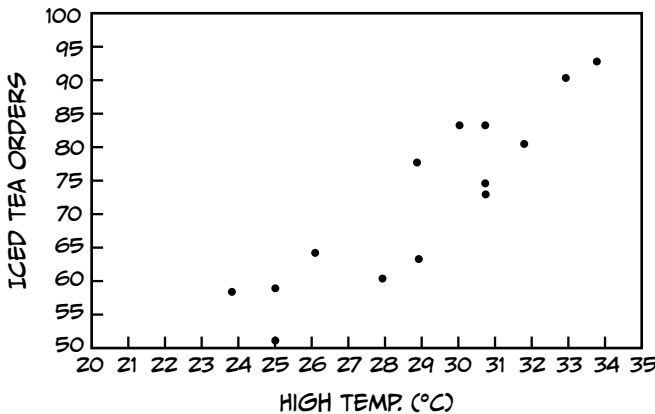

...LIKE THIS.

I SEE.

SEE HOW THE DOTS ROUGHLY LINE UP? THAT SUGGESTS THESE VARIABLES ARE CORRELATED. THE CORRELATION COEFFICIENT, CALLED R , INDICATES HOW STRONG THE CORRELATION IS.

$R = 0.9069$

R RANGES FROM $+1$ TO -1 , AND THE FURTHER IT IS FROM ZERO, THE STRONGER THE CORRELATION.* I'LL SHOW YOU HOW TO WORK OUT THE CORRELATION COEFFICIENT ON PAGE 78.

* A POSITIVE R VALUE INDICATES A POSITIVE RELATIONSHIP, MEANING AS x INCREASES, SO DOES y . A NEGATIVE R VALUE MEANS AS THE x VALUE INCREASES, THE y VALUE DECREASES.

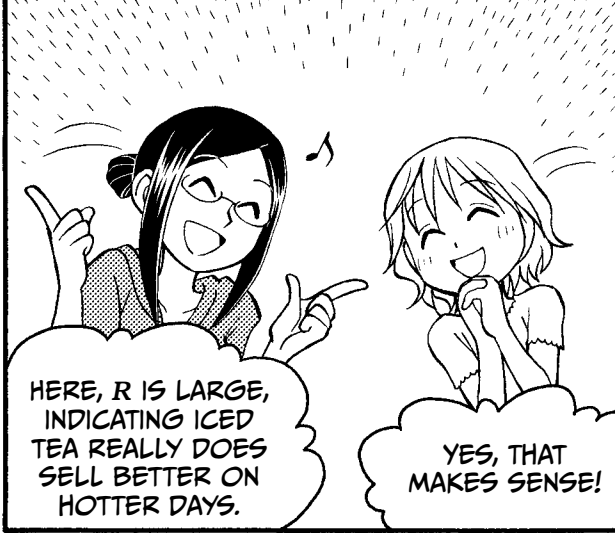

HERE, R IS LARGE, INDICATING ICED TEA REALLY DOES SELL BETTER ON HOTTER DAYS.

YES, THAT MAKES SENSE!



BUT IT'S NOT REALLY SURPRISING.

OBVIOUSLY MORE PEOPLE ORDER ICED TEA WHEN IT'S HOT OUT.

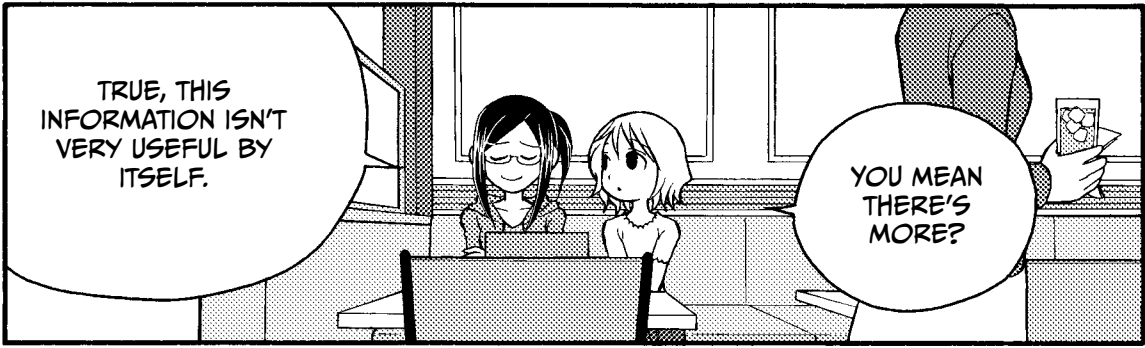

TRUE, THIS INFORMATION ISN'T VERY USEFUL BY ITSELF.

YOU MEAN THERE'S MORE?



SURE! WE HAVEN'T EVEN BEGUN THE REGRESSION ANALYSIS.

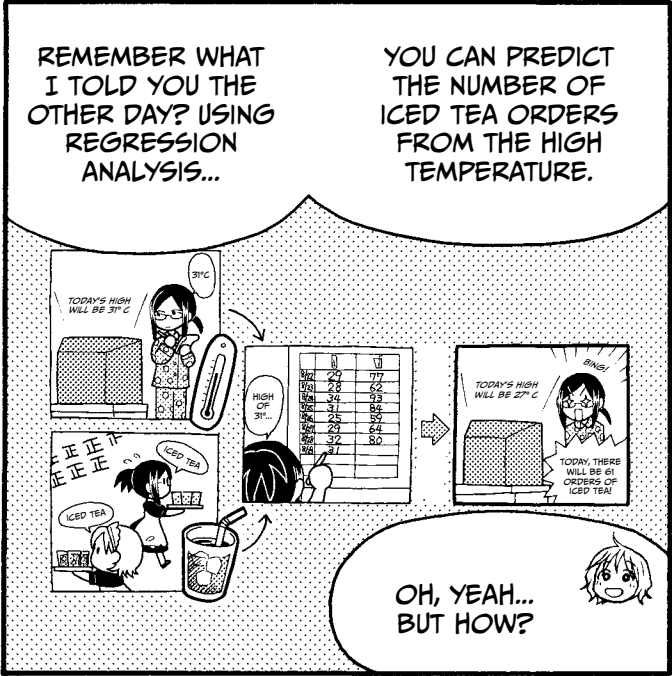

REMEMBER WHAT I TOLD YOU THE OTHER DAY? USING REGRESSION ANALYSIS...

YOU CAN PREDICT THE NUMBER OF ICED TEA ORDERS FROM THE HIGH TEMPERATURE.

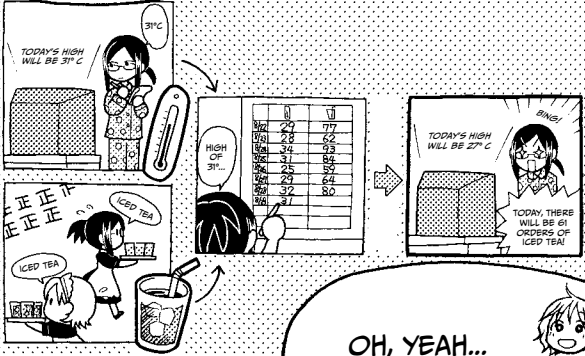

OH, YEAH... BUT HOW?

THE REGRESSION EQUATION

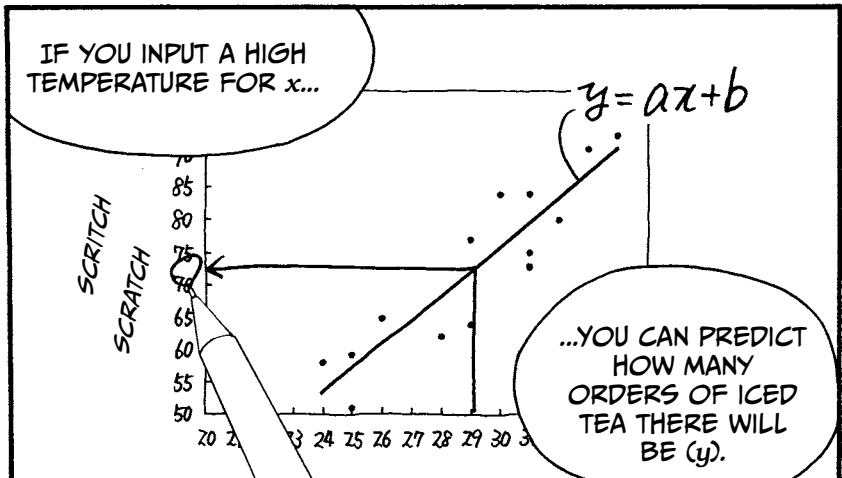
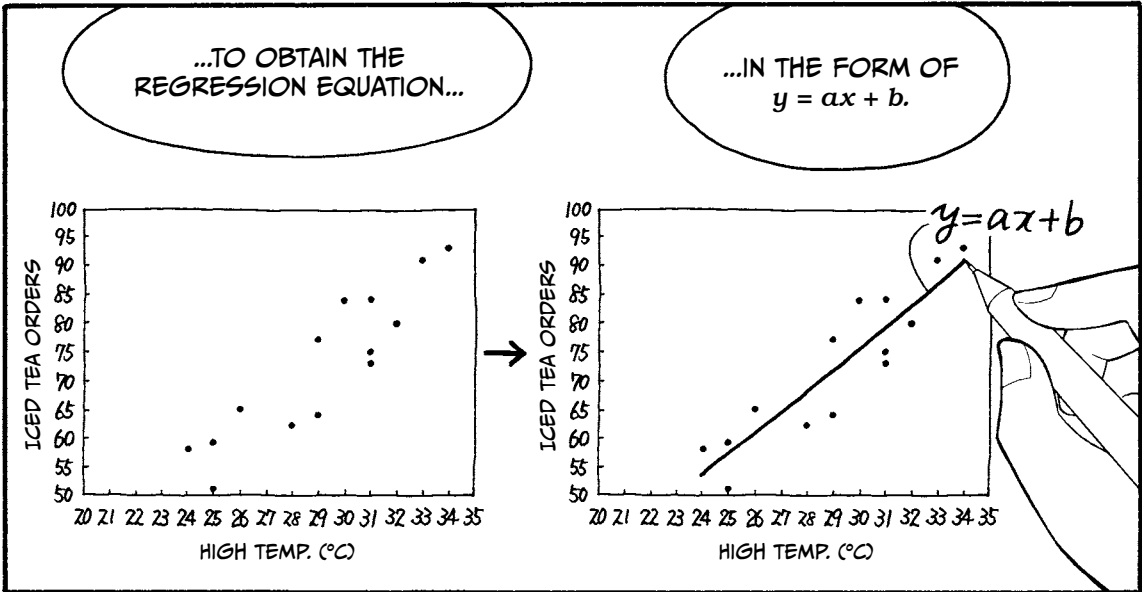
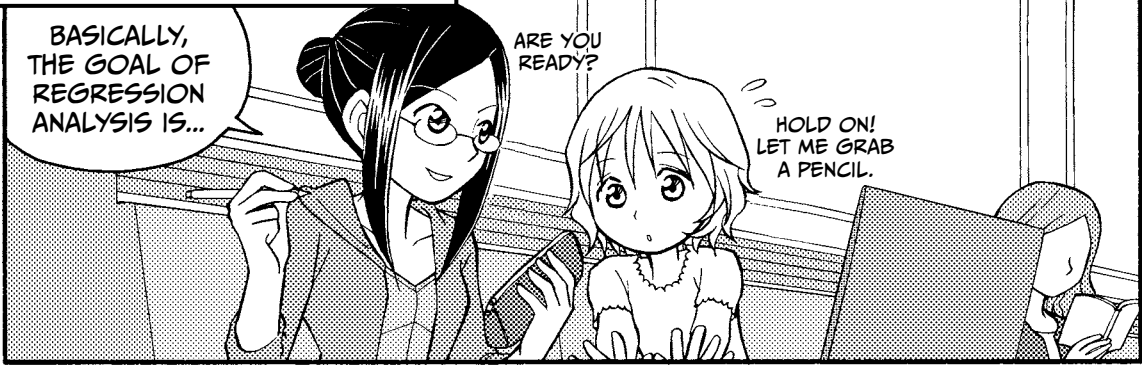

I SEE! REGRESSION ANALYSIS DOESN'T SEEM TOO HARD.

JUST YOU WAIT...

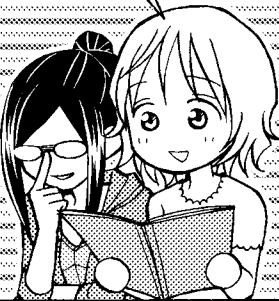

AS I SAID EARLIER, y IS THE DEPENDENT (OR OUTCOME) VARIABLE AND x IS THE INDEPENDENT (OR PREDICTOR) VARIABLE.

$$y = ax + b$$

DEPENDENT VARIABLE

INDEPENDENT VARIABLE

a IS THE REGRESSION COEFFICIENT, WHICH TELLS US THE SLOPE OF THE LINE WE MAKE.

THAT LEAVES US WITH b , THE INTERCEPT. THIS TELLS US WHERE OUR LINE CROSSES THE y -AXIS.

OKAY, GOT IT.

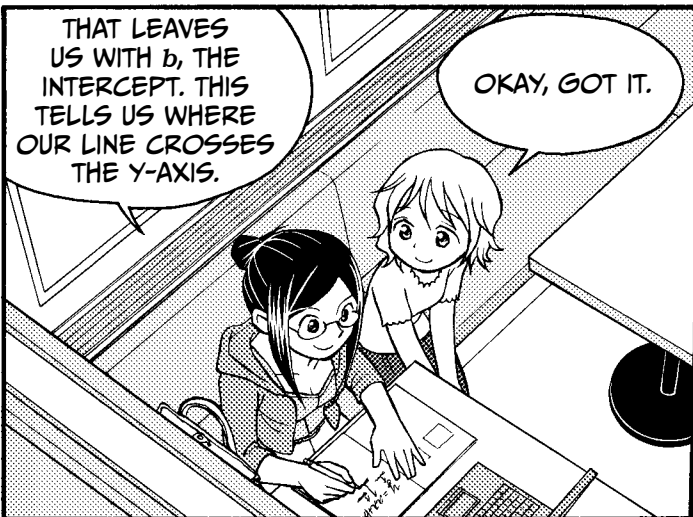

SO HOW DO I GET THE REGRESSION EQUATION?

HOLD ON, MIU.



FINDING THE EQUATION IS ONLY PART OF THE STORY.

YOU ALSO NEED TO LEARN HOW TO VERIFY THE ACCURACY OF YOUR EQUATION BY TESTING FOR CERTAIN CIRCUMSTANCES. LET'S LOOK AT THE PROCESS AS A WHOLE.

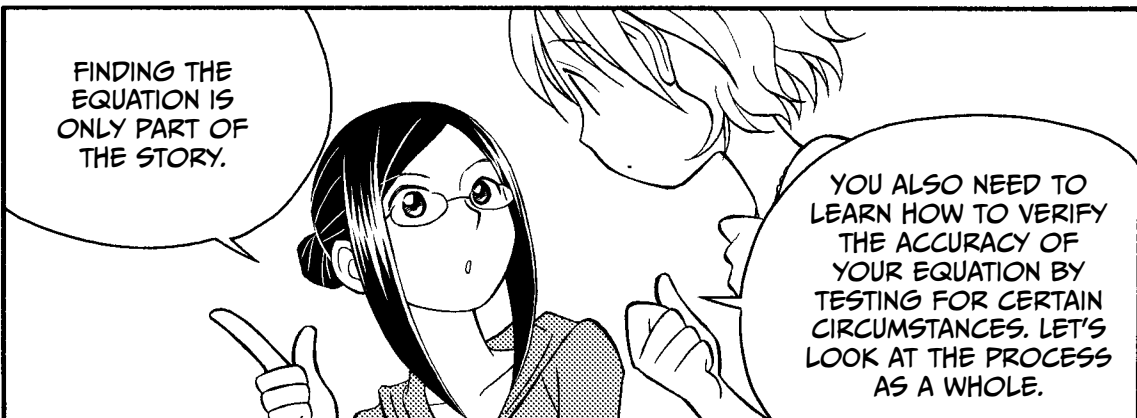

GENERAL REGRESSION ANALYSIS PROCEDURE

HERE'S AN OVERVIEW OF REGRESSION ANALYSIS.

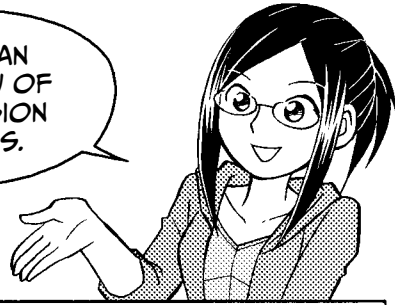

STEP 1

DRAW A SCATTER PLOT OF THE INDEPENDENT VARIABLE VERSUS THE DEPENDENT VARIABLE. IF THE DOTS LINE UP, THE VARIABLES MAY BE CORRELATED.



STEP 2

CALCULATE THE REGRESSION EQUATION.

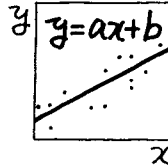

STEP 3

CALCULATE THE CORRELATION COEFFICIENT (R) AND ASSESS OUR POPULATION AND ASSUMPTIONS.

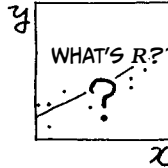

STEP 4

CONDUCT THE ANALYSIS OF VARIANCE.

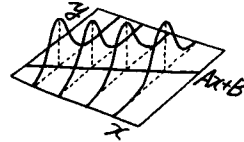

STEP 5

CALCULATE THE CONFIDENCE INTERVALS.

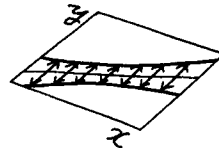

STEP 6

MAKE A PREDICTION!

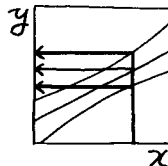

REGRESSION DIAGNOSTICS

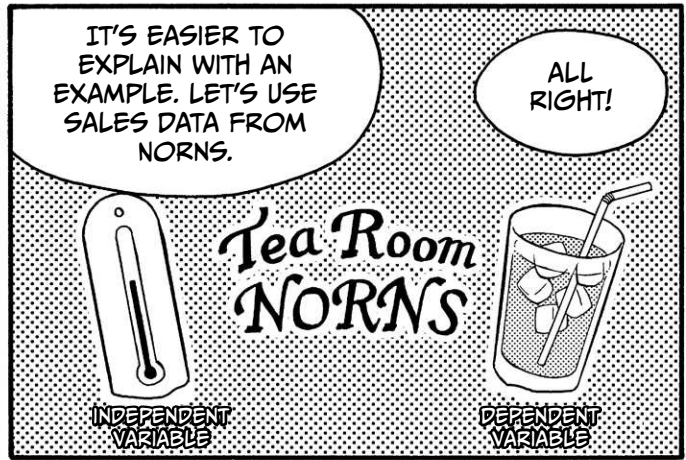
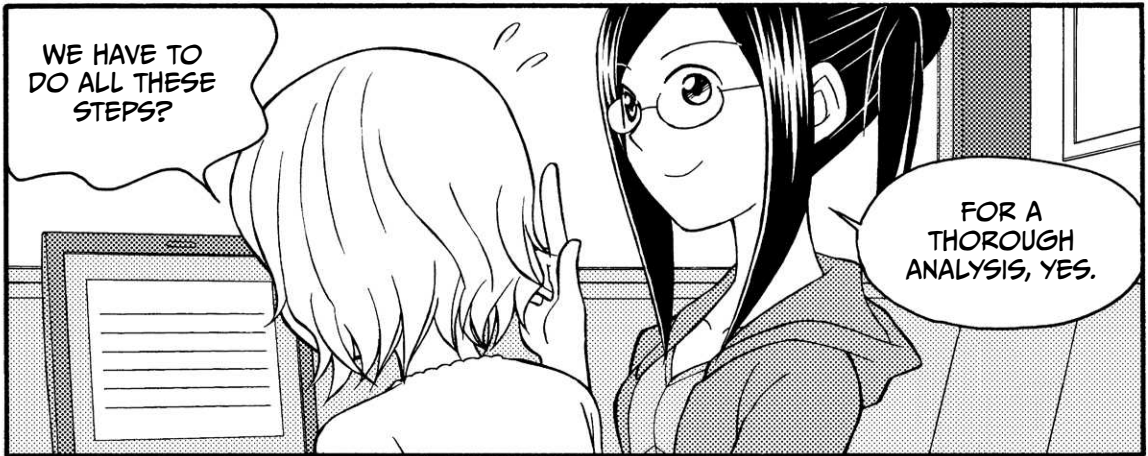

STEP 1: DRAW A SCATTER PLOT OF THE INDEPENDENT VARIABLE VERSUS THE DEPENDENT VARIABLE. IF THE DOTS LINE UP, THE VARIABLES MAY BE CORRELATED.

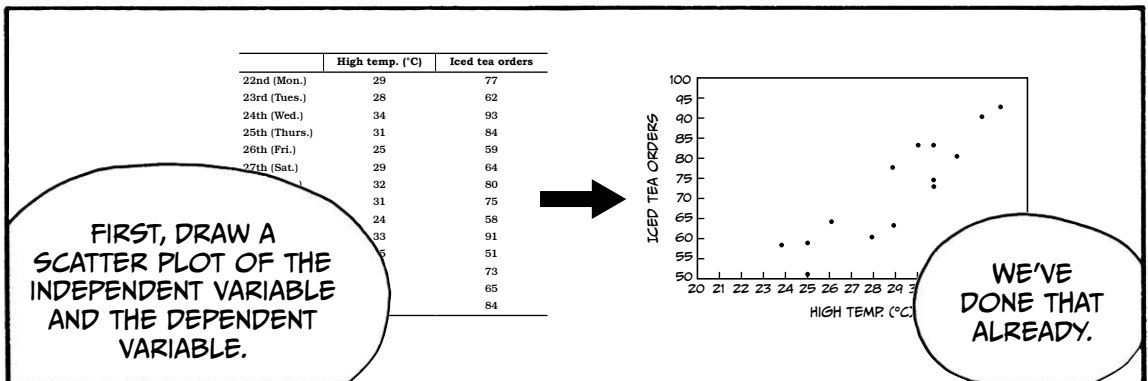

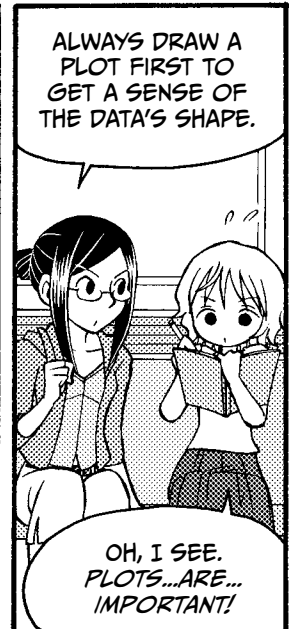
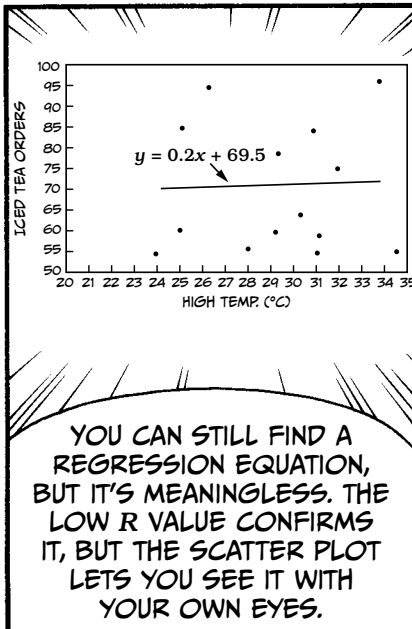
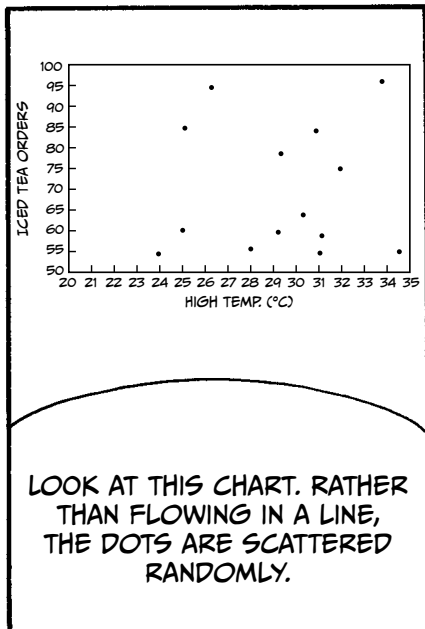
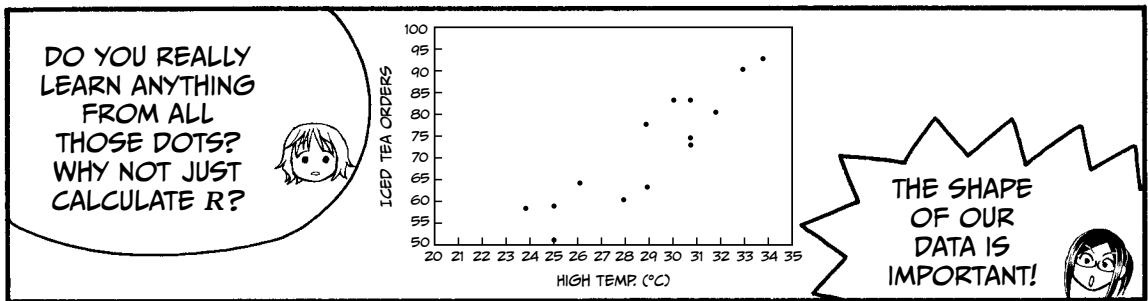
STEP 2: CALCULATE THE REGRESSION EQUATION.

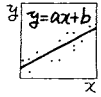

NOW, LET'S MAKE A REGRESSION EQUATION!

LET'S FIND a AND b !

$y = ax + b$

FINALLY, THE TIME HAS COME.

LET'S DRAW A STRAIGHT LINE, FOLLOWING THE PATTERN IN THE DATA AS BEST WE CAN.

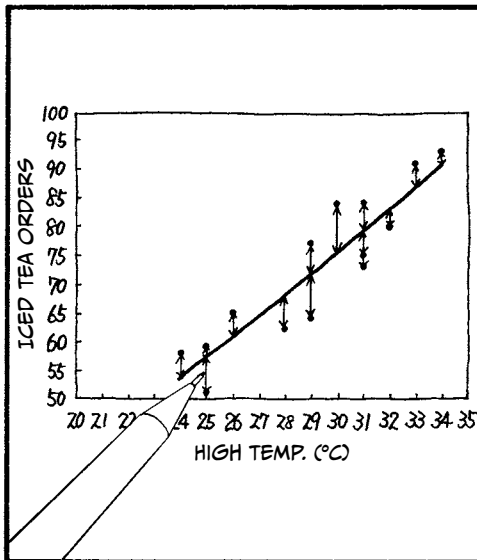

THE LITTLE ARROWS ARE THE DISTANCES FROM THE LINE, WHICH REPRESENTS THE ESTIMATED VALUES OF EACH DOT, WHICH ARE THE ACTUAL MEASURED VALUES. THE DISTANCES ARE CALLED RESIDUALS. THE GOAL IS TO FIND THE LINE THAT BEST MINIMIZES ALL THE RESIDUALS.

THIS IS CALLED LINEAR LEAST SQUARES REGRESSION.

WE SQUARE THE RESIDUALS TO FIND THE SUM OF SQUARES, WHICH WE USE TO FIND THE REGRESSION EQUATION.

- Step 1** Calculate S_{xx} (sum of squares of x), S_{yy} (sum of squares of y), and S_{xy} (sum of products of x and y).
- Step 2** Calculate S_e (residual sum of squares).
- Step 3** Differentiate S_e with respect to a and b , and set it equal to 0.
- Step 4** Separate out a and b .
- Step 5** Isolate the a component.
- Step 6** Find the regression equation.

I'LL ADD THIS TO MY NOTES.

STEPS WITHIN STEPS?!

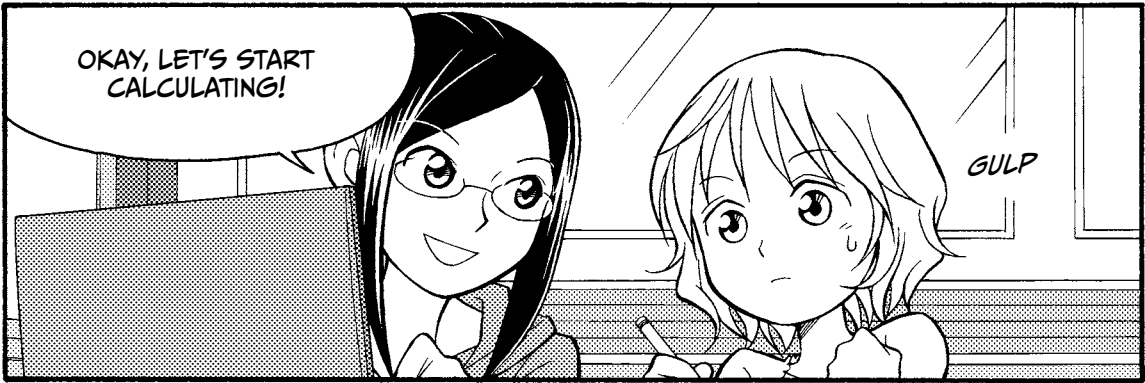

Step 1

Find

- The sum of squares of x , S_{xx} : $(x - \bar{x})^2$
- The sum of squares of y , S_{yy} : $(y - \bar{y})^2$
- The sum of products of x and y , S_{xy} : $(x - \bar{x})(y - \bar{y})$

Note: The bar over a variable (like \bar{x}) is a notation that means *average*. We can call this variable *x-bar*.

	High temp. in °C	Iced tea orders					
	x	y	$x - \bar{x}$	$y - \bar{y}$	$(x - \bar{x})^2$	$(y - \bar{y})^2$	$(x - \bar{x})(y - \bar{y})$
22nd (Mon.)	29	77	-0.1	4.4	0.0	19.6	-0.6
23rd (Tues.)	28	62	-1.1	-10.6	1.3	111.8	12.1
24th (Wed.)	34	93	4.9	20.4	23.6	417.3	99.2
25th (Thurs.)	31	84	1.9	11.4	3.4	130.6	21.2
26th (Fri.)	25	59	-4.1	-13.6	17.2	184.2	56.2
27th (Sat.)	29	64	-0.1	-8.6	0.0	73.5	1.2
28th (Sun.)	32	80	2.9	7.4	8.2	55.2	21.2
29th (Mon.)	31	75	1.9	2.4	3.4	5.9	4.5
30th (Tues.)	24	58	-5.1	-14.6	26.4	212.3	74.9
31st (Wed.)	33	91	3.9	18.4	14.9	339.6	71.1
1st (Thurs.)	25	51	-4.1	-21.6	17.2	465.3	89.4
2nd (Fri.)	31	73	1.9	0.4	3.4	0.2	0.8
3rd (Sat.)	26	65	-3.1	-7.6	9.9	57.8	23.8
4th (Sun.)	30	84	0.9	11.4	0.7	130.6	9.8
Sum	408	1016	0	0	129.7	2203.4	484.9
Average	29.1	72.6					
	↓	↓			↓	↓	↓
	\bar{x}	\bar{y}			S_{xx}	S_{yy}	S_{xy}

* SOME OF THE FIGURES IN THIS CHAPTER ARE ROUNDED FOR THE SAKE OF PRINTING, BUT CALCULATIONS ARE DONE USING THE FULL, UNROUNDED VALUES RESULTING FROM THE RAW DATA UNLESS OTHERWISE STATED.

Step 2

Find the residual sum of squares, S_e .

- y is the observed value.
- \hat{y} is the the estimated value based on our regression equation.
- $y - \hat{y}$ is called the residual and is written as e .

Note: The caret in \hat{y} is affectionately called a *hat*, so we call this parameter estimate *y-hat*.

	High temp. in °C x	Actual iced tea orders y	Predicted iced tea orders $\hat{y} = ax + b$	Residuals (e) $y - \hat{y}$	Squared residuals $(y - \hat{y})^2$
22nd (Mon.)	29	77	$a \times 29 + b$	$77 - (a \times 29 + b)$	$[77 - (a \times 29 + b)]^2$
23rd (Tues.)	28	62	$a \times 28 + b$	$62 - (a \times 28 + b)$	$[62 - (a \times 28 + b)]^2$
24th (Wed.)	34	93	$a \times 34 + b$	$93 - (a \times 34 + b)$	$[93 - (a \times 34 + b)]^2$
25th (Thurs.)	31	84	$a \times 31 + b$	$84 - (a \times 31 + b)$	$[84 - (a \times 31 + b)]^2$
26th (Fri.)	25	59	$a \times 25 + b$	$59 - (a \times 25 + b)$	$[59 - (a \times 25 + b)]^2$
27th (Sat.)	29	64	$a \times 29 + b$	$64 - (a \times 29 + b)$	$[64 - (a \times 29 + b)]^2$
28th (Sun.)	32	80	$a \times 32 + b$	$80 - (a \times 32 + b)$	$[80 - (a \times 32 + b)]^2$
29th (Mon.)	31	75	$a \times 31 + b$	$75 - (a \times 31 + b)$	$[75 - (a \times 31 + b)]^2$
30th (Tues.)	24	58	$a \times 24 + b$	$58 - (a \times 24 + b)$	$[58 - (a \times 24 + b)]^2$
31st (Wed.)	33	91	$a \times 33 + b$	$91 - (a \times 33 + b)$	$[91 - (a \times 33 + b)]^2$
1st (Thurs.)	25	51	$a \times 25 + b$	$51 - (a \times 25 + b)$	$[51 - (a \times 25 + b)]^2$
2nd (Fri.)	31	73	$a \times 31 + b$	$73 - (a \times 31 + b)$	$[73 - (a \times 31 + b)]^2$
3rd (Sat.)	26	65	$a \times 26 + b$	$65 - (a \times 26 + b)$	$[65 - (a \times 26 + b)]^2$
4th (Sun.)	30	84	$a \times 30 + b$	$84 - (a \times 30 + b)$	$[84 - (a \times 30 + b)]^2$
Sum	408	1016	$408a + 14b$	$1016 - (408a + 14b)$	S_e
Average	29.1	72.6	$29.1a + b$ $= \bar{x}a + b$	$72.6 - (29.1a + b)$ $= \bar{y} - (\bar{x}a + b)$	$= \frac{S_e}{14}$

↓
 \bar{x}

↓
 \bar{y}

$$S_e = [77 - (a \times 29 + b)]^2 + \dots + [84 - (a \times 30 + b)]^2$$

THE SUM OF THE RESIDUALS SQUARED IS CALLED THE RESIDUAL SUM OF SQUARES. IT IS WRITTEN AS S_e OR RSS.

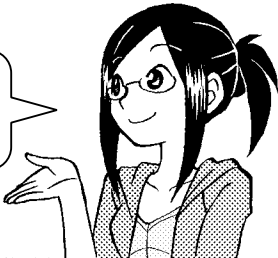

Step3

Differentiate S_e with respect to a and b , and set it equal to 0. When differentiating $y = (ax + b)^n$ with respect to x , the result is

$$\frac{dy}{dx} = n(ax + b)^{n-1} \times a.$$

- Differentiate with respect to a .

$$\frac{dS_e}{da} = 2[77 - (29a + b)] \times (-29) + \dots + 2[84 - (30a + b)] \times (-30) = 0 \quad \text{①}$$

- Differentiate with respect to b .

$$\frac{dS_e}{db} = 2[77 - (29a + b)] \times (-1) + \dots + 2[84 - (30a + b)] \times (-1) = 0 \quad \text{②}$$

Step4

Rearrange ① and ② from the previous step.

Rearrange ①.

$$2[77 - (29a + b)] \times (-29) + \dots + 2[84 - (30a + b)] \times (-30) = 0$$

$$[77 - (29a + b)] \times (-29) + \dots + [84 - (30a + b)] \times (-30) = 0 \quad \text{DIVIDE BOTH SIDES BY 2.}$$

$$29[(29a + b) - 77] + \dots + 30[(30a + b) - 84] = 0 \quad \text{MULTIPLY BY -1.}$$

$$(29 \times 29a + 29 \times b - 29 \times 77) + \dots + (30 \times 30a + 30 \times b - 30 \times 84) = 0 \quad \text{MULTIPLY.}$$

$$\text{③ } (29^2 + \dots + 30^2)a + (29 + \dots + 30)b - (29 \times 77 + \dots + 30 \times 84) = 0 \quad \text{SEPARATE OUT } a \text{ AND } b.$$

Rearrange ②.

$$2[77 - (29a + b)] \times (-1) + \dots + 2[84 - (30a + b)] \times (-1) = 0$$

$$[77 - (29a + b)] \times (-1) + \dots + [84 - (30a + b)] \times (-1) = 0 \quad \text{DIVIDE BOTH SIDES BY 2.}$$

$$[(29a + b) - 77] + \dots + [(30a + b) - 84] = 0 \quad \text{MULTIPLY BY -1.}$$

$$(29 + \dots + 30)a + \underbrace{b + \dots + b}_{14} - (77 + \dots + 84) = 0 \quad \text{SEPARATE OUT } a \text{ AND } b.$$

$$(29 + \dots + 30)a + 14b - (77 + \dots + 84) = 0$$

$$14b = (77 + \dots + 84) - (29 + \dots + 30)a \quad \text{SUBTRACT } 14b \text{ FROM BOTH SIDES AND MULTIPLY BY -1.}$$

$$\text{④ } b = \frac{77 + \dots + 84}{14} - \frac{29 + \dots + 30}{14}a \quad \text{ISOLATE } b \text{ ON THE LEFT SIDE OF THE EQUATION.}$$

$$\text{⑤ } b = \bar{y} - \bar{x}a \quad \text{THE COMPONENTS IN ④ ARE THE AVERAGES OF } y \text{ AND } x.$$

Step 5

Plug the value of b found in 4 into line 3 (3 and 4 are the results from Step 4).

3 $(29^2 + \dots + 30^2)a + (29 + \dots + 30) \left(\frac{77 + \dots + 84}{14} - \frac{29 + \dots + 30}{14} a \right) - (29 \times 77 + \dots + 30 \times 84) = 0$ NOW a IS THE ONLY VARIABLE.

$$(29^2 + \dots + 30^2)a + \frac{(29 + \dots + 30)(77 + \dots + 84)}{14} - \frac{(29 + \dots + 30)^2}{14}a - (29 \times 77 + \dots + 30 \times 84) = 0$$

$$\left[(29^2 + \dots + 30^2) - \frac{(29 + \dots + 30)^2}{14} \right] a + \frac{(29 + \dots + 30)(77 + \dots + 84)}{14} - (29 \times 77 + \dots + 30 \times 84) = 0$$
 COMBINE THE a TERMS.

$$\left[(29^2 + \dots + 30^2) - \frac{(29 + \dots + 30)^2}{14} \right] a = (29 \times 77 + \dots + 30 \times 84) - \frac{(29 + \dots + 30)(77 + \dots + 84)}{14}$$
 TRANSPOSE.

Rearrange the left side of the equation.

$$\begin{aligned} & (29^2 + \dots + 30^2) - \frac{(29 + \dots + 30)^2}{14} \\ &= (29^2 + \dots + 30^2) - 2 \times \frac{(29 + \dots + 30)^2}{14} + \frac{(29 + \dots + 30)^2}{14} \quad \text{WE ADD AND SUBTRACT } \frac{(29 + \dots + 30)^2}{14}. \\ &= (29^2 + \dots + 30^2) - 2 \times (29 + \dots + 30) \times \frac{29 + \dots + 30}{14} + \left(\frac{29 + \dots + 30}{14} \right)^2 \times 14 \quad \text{THE LAST TERM IS MULTIPLIED BY } \frac{14}{14}. \\ &= (29^2 + \dots + 30^2) - 2 \times (29 + \dots + 30) \times \bar{x} + (\bar{x})^2 \times 14 \quad \bar{x} = \frac{29 + \dots + 30}{14} \\ &= (29^2 + \dots + 30^2) - 2 \times (29 + \dots + 30) \times \bar{x} + \underbrace{(\bar{x})^2 + \dots + (\bar{x})^2}_{14} \\ &= [29^2 - 2 \times 29 \times \bar{x} + (\bar{x})^2] + \dots + [30^2 - 2 \times 30 \times \bar{x} + (\bar{x})^2] \\ &= (29 - \bar{x})^2 + \dots + (30 - \bar{x})^2 \\ &= S_{xx} \end{aligned}$$

Rearrange the right side of the equation.

$$\begin{aligned} & (29 \times 77 + \dots + 30 \times 84) - \frac{(29 + \dots + 30)(77 + \dots + 84)}{14} \\ &= (29 \times 77 + \dots + 30 \times 84) - \frac{29 + \dots + 30}{14} \times \frac{77 + \dots + 84}{14} \times 14 \\ &= (29 \times 77 + \dots + 30 \times 84) - \bar{x} \times \bar{y} \times 14 \\ &= (29 \times 77 + \dots + 30 \times 84) - \bar{x} \times \bar{y} \times 14 - \bar{x} \times \bar{y} \times 14 + \bar{x} \times \bar{y} \times 14 \quad \text{WE ADD AND SUBTRACT } \bar{x} \times \bar{y} \times 14. \\ &= (29 \times 77 + \dots + 30 \times 84) - \frac{29 + \dots + 30}{14} \times \bar{y} \times 14 - \bar{x} \times \frac{77 + \dots + 84}{14} \times 14 + \bar{x} \times \bar{y} \times 14 \\ &= (29 \times 77 + \dots + 30 \times 84) - (29 + \dots + 30) \bar{y} - \bar{x} (77 + \dots + 84) + \bar{x} \times \bar{y} \times 14 \\ &= (29 \times 77 + \dots + 30 \times 84) - (29 + \dots + 30) \bar{y} - (77 + \dots + 84) \bar{x} + \underbrace{\bar{x} \times \bar{y} + \dots + \bar{x} \times \bar{y}}_{14} \\ &= (29 - \bar{x})(77 - \bar{y}) + \dots + (30 - \bar{x})(84 - \bar{y}) \\ &= S_{xy} \end{aligned}$$

$$S_{xx} a = S_{xy}$$

6 $a = \frac{S_{xy}}{S_{xx}}$ ISOLATE a ON THE LEFT SIDE OF THE EQUATION.

Step 6 Calculate the regression equation.

From ⑥ in Step 5, $a = \frac{S_{xy}}{S_{xx}}$. From ⑤ in Step 4, $b = \bar{y} - \bar{x}a$.

If we plug in the values we calculated in Step 1,

$$\begin{cases} a = \frac{S_{xx}}{S_{xy}} = \frac{484.9}{129.7} = 3.7 \\ b = \bar{y} - \bar{x}a = 72.6 - 29.1 \times 3.7 = -36.4 \end{cases}$$

then the regression equation is

$$y = 3.7x - 36.4.$$

It's that simple!

Note: The values shown are rounded for the sake of printing, but the result (36.4) was calculated using the full, unrounded values.

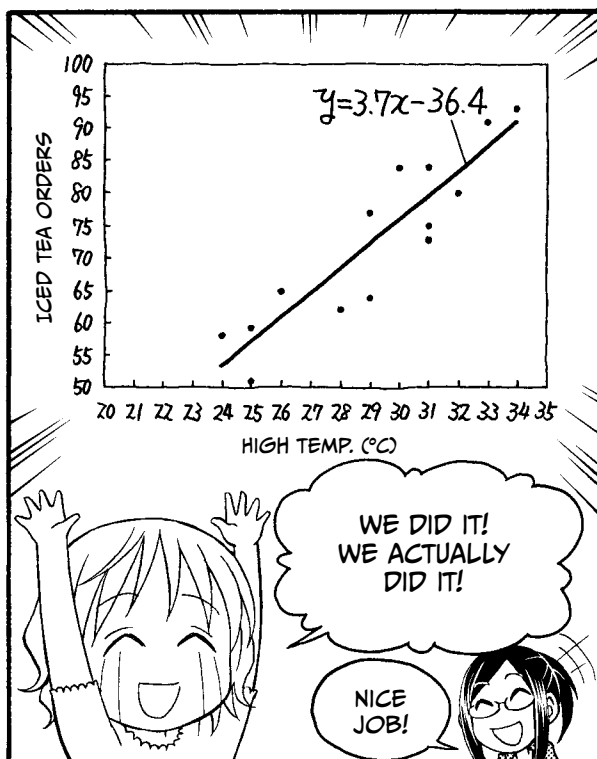

THE RELATIONSHIP BETWEEN THE RESIDUALS AND THE SLOPE a AND INTERCEPT b IS ALWAYS

$$a = \frac{\text{sum of products of } x \text{ and } y}{\text{sum of squares of } x} = \frac{S_{xy}}{S_{xx}}$$

$$b = \bar{y} - \bar{x}a$$

THIS IS TRUE FOR ANY LINEAR REGRESSION.

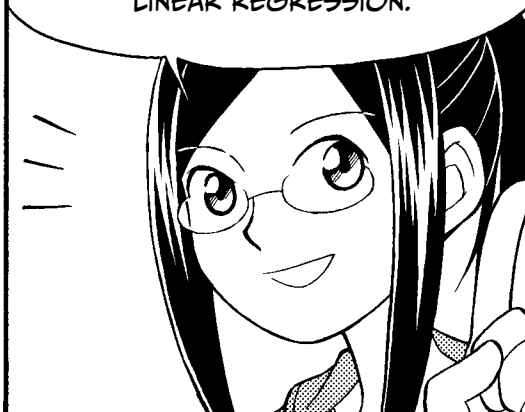

SO, MIU, WHAT ARE THE AVERAGE VALUES FOR THE HIGH TEMPERATURE AND THE ICED TEA ORDERS?

LET ME SEE...

29.1°C AND 72.6 ORDERS.

REMEMBER, THE AVERAGE TEMPERATURE IS \bar{x} AND THE AVERAGE NUMBER OF ORDERS IS \bar{y} . NOW FOR A LITTLE MAGIC.

WITHOUT LOOKING, I CAN TELL YOU THAT THE REGRESSION EQUATION CROSSES THE POINT (29.1, 72.6). IT DOES!

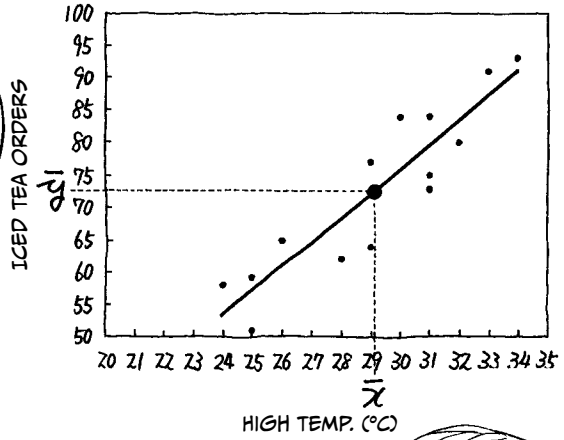

THE REGRESSION EQUATION CAN BE...

$$y = ax + b$$

$$= ax + (\bar{y} - \bar{x}a)$$

$$= a(x - \bar{x}) + \bar{y}$$

...REARRANGED LIKE THIS.

I SEE!

THAT'S FROM STEP 4!

NOW, IF WE SET x TO THE AVERAGE VALUE (\bar{x}) WE FOUND BEFORE...

$$= a(x - \bar{x}) + \bar{y}$$

$$= a(\bar{x} - \bar{x}) + \bar{y}$$

$$= a \times 0 + \bar{y}$$

$$= \bar{y}$$

SEE WHAT HAPPENS?

WHEN x IS THE AVERAGE, SO IS y !

STEP 3: CALCULATE THE CORRELATION COEFFICIENT (R) AND ASSESS OUR POPULATION AND ASSUMPTIONS.

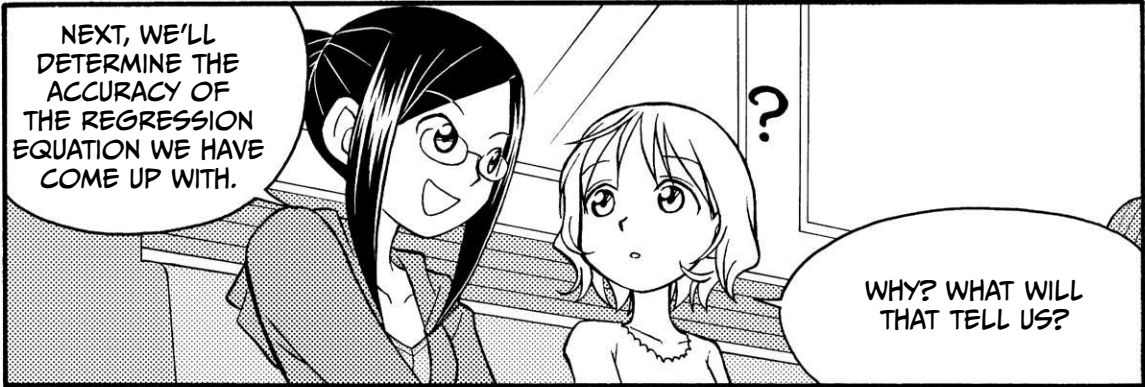
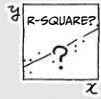

OUR DATA AND ITS REGRESSION EQUATION

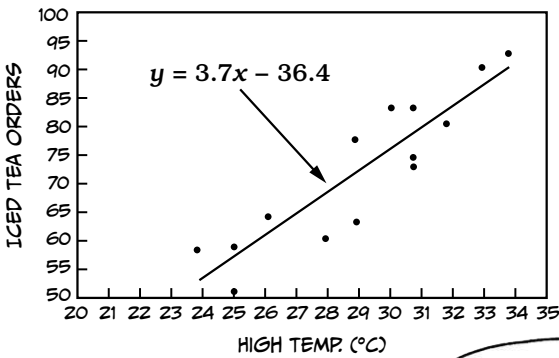

EXAMPLE DATA AND ITS REGRESSION EQUATION

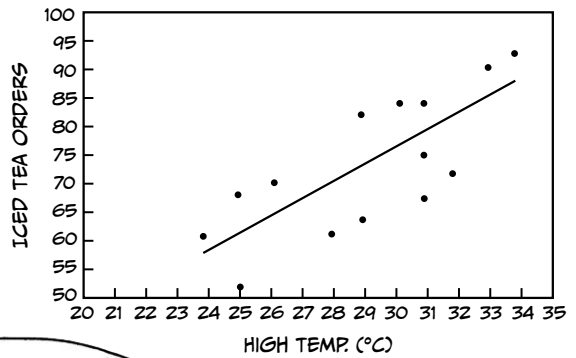

MIU, CAN YOU SEE A DIFFERENCE BETWEEN THESE TWO GRAPHS?

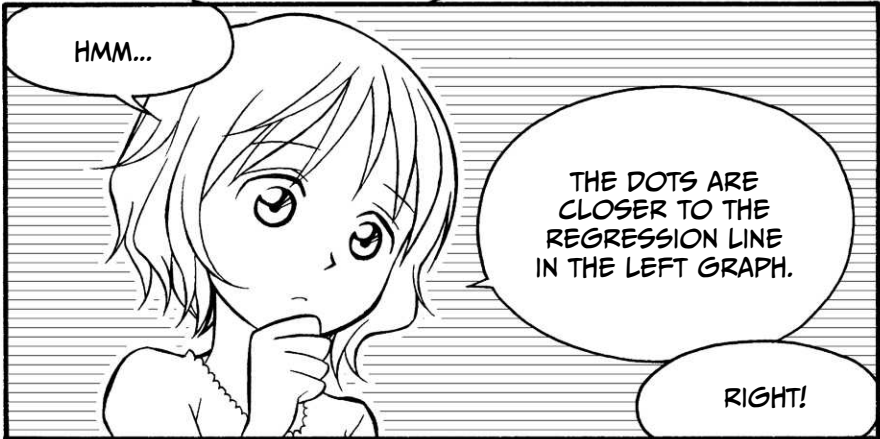

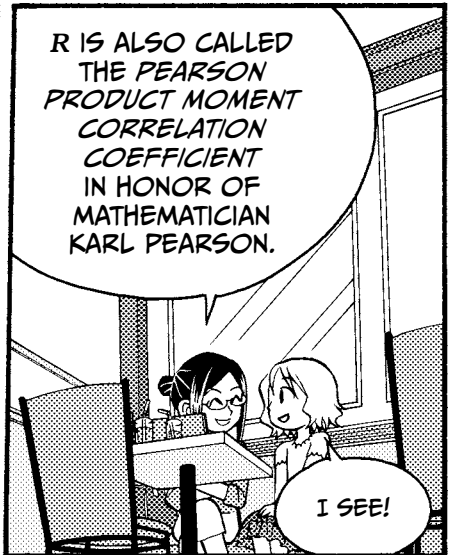
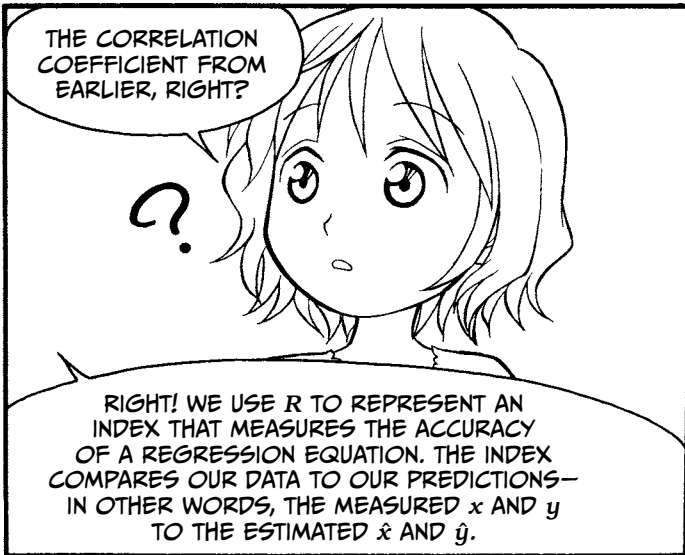
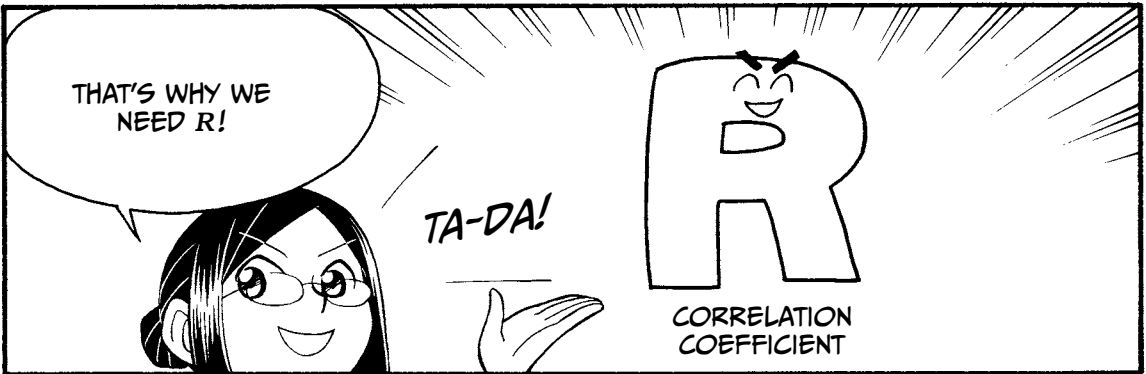
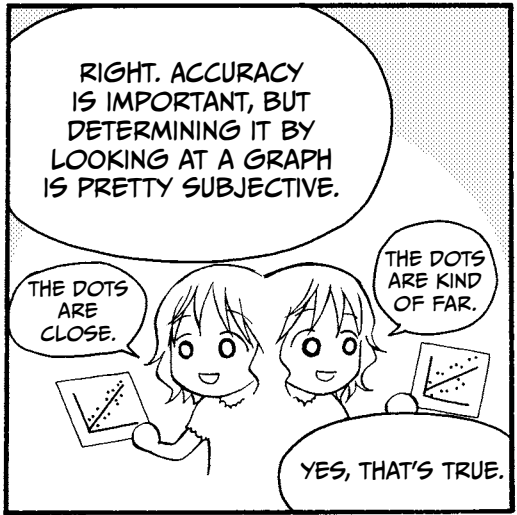
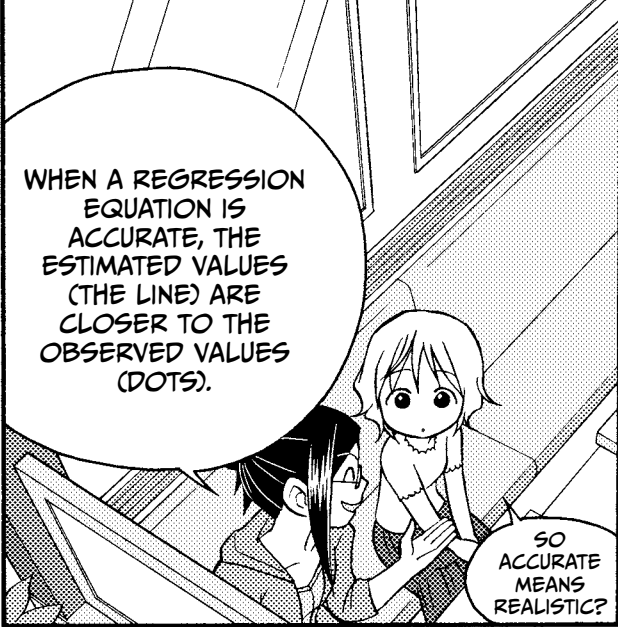

HERE'S THE EQUATION. WE CALCULATE THESE LIKE WE DID S_{xx} AND S_{xy} BEFORE.

$$R = \frac{\text{sum of products } y \text{ and } \hat{y}}{\sqrt{\text{sum of squares of } y \times \text{sum of squares of } \hat{y}}} = \frac{S_{y\hat{y}}}{\sqrt{S_{yy} \times S_{\hat{y}\hat{y}}}}$$

$$= \frac{1812.3}{\sqrt{2203.4 \times 1812.3}} = 0.9069$$



THAT'S NOT TOO BAD!



THIS LOOKS FAMILIAR.

REGRESSION FUNCTION!

	Actual values y	Estimated values $\hat{y} = 3.7x - 36.4$	$y - \bar{y}$	$\hat{y} - \bar{\hat{y}}$	$(y - \bar{y})^2$	$(\hat{y} - \bar{\hat{y}})^2$	$(y - \bar{y})(\hat{y} - \bar{\hat{y}})$	$(y - \bar{y})^2$
22nd (Mon.)	77	72.0	4.4	-0.5	19.6	0.3	-2.4	24.6
23rd (Tues.)	62	68.3	-10.6	-4.3	111.8	18.2	45.2	39.7
24th (Wed.)	93	90.7	20.4	18.2	417.3	329.6	370.9	5.2
25th (Thurs.)	84	79.5	11.4	6.9	130.6	48.2	79.3	20.1
26th (Fri.)	59	57.1	-13.6	-15.5	184.2	239.8	210.2	3.7
27th (Sat.)	64	72.0	-8.6	-0.5	73.5	0.3	4.6	64.6
28th (Sun.)	80	83.3	7.4	10.7	55.2	114.1	79.3	10.6
29th (Mon.)	75	79.5	2.4	6.9	5.9	48.2	16.9	20.4
30th (Tues.)	58	53.3	-14.6	-19.2	212.3	369.5	280.1	21.6
31st (Wed.)	91	87.0	18.4	14.4	339.6	207.9	265.7	16.1
1st (Thurs.)	51	57.1	-21.6	-15.5	465.3	239.8	334.0	37.0
2nd (Fri.)	73	79.5	0.4	6.9	0.2	48.2	3.0	42.4
3rd (Sat.)	65	60.8	-7.6	-11.7	57.3	138.0	88.9	17.4
4th (Sun.)	84	75.8	11.4	3.2	130.6	10.3	36.6	67.6
Sum	1016	1016	0	0	2203.4	1812.3	1812.3	391.1
Average	72.6	72.6						
	\bar{y}	$\bar{\hat{y}}$			S_{yy}	$S_{\hat{y}\hat{y}}$	$S_{y\hat{y}}$	S_e

S_e ISN'T NECESSARY FOR CALCULATING R , BUT I INCLUDED IT BECAUSE WE'LL NEED IT LATER.



IF WE SQUARE R, IT'S CALLED THE COEFFICIENT OF DETERMINATION AND IS WRITTEN AS R^2 .

R^2 CAN BE AN INDICATOR OF...

I AM A CORRELATION COEFFICIENT.

I AM A CORRELATION COEFFICIENT, TOO.

I AM A CORRELATION COEFFICIENT.

I AM A COEFFICIENT OF DETERMINATION.

...HOW MUCH VARIANCE IS EXPLAINED BY OUR REGRESSION EQUATION.

$R \times R = R^2$

AN R^2 OF ZERO INDICATES THAT THE OUTCOME VARIABLE CAN'T BE RELIABLY PREDICTED FROM THE PREDICTOR VARIABLE.

0

1

THE HIGHER THE ACCURACY OF THE REGRESSION EQUATION, THE CLOSER THE R^2 VALUE IS TO 1, AND VICE VERSA.

SO HOW HIGH DOES R^2 NEED TO BE FOR THE REGRESSION EQUATION TO BE CONSIDERED ACCURATE?

UNFORTUNATELY, THERE IS NO UNIVERSAL STANDARD IN STATISTICS.

BUT GENERALLY WE WANT A VALUE OF AT LEAST .5.

LOWEST...
.5...

NOW TRY FINDING THE VALUE OF R^2 .

SURE THING.

$$R^2 = (0.9069)^2$$

$$= 0.8225$$

IT'S .8225.

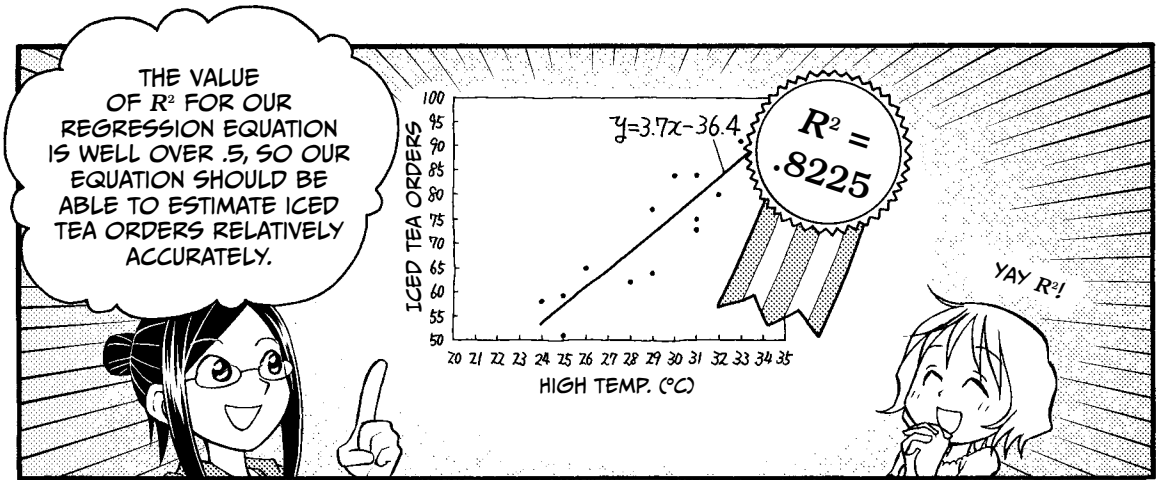

$$R^2 = \left(\frac{\text{correlation}}{\text{coefficient}} \right)^2 = \frac{a \times S_{xy}}{S_{yy}} = 1 - \frac{S_e}{S_{yy}}$$

JOT THIS EQUATION DOWN. R^2 CAN BE CALCULATED DIRECTLY FROM THESE VALUES. USING OUR NORNS DATA, $1 - (391.1 / 2203.4) = .8225!$

THAT'S HANDY!

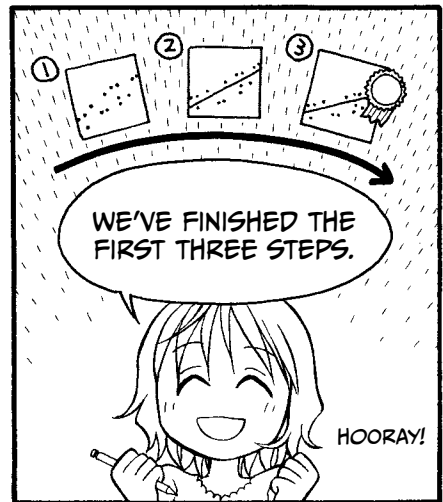

SAMPLES AND POPULATIONS

NOW TO ASSESS THE POPULATION AND VERIFY THAT OUR ASSUMPTIONS ARE MET!

OH...

I MEANT TO ASK YOU ABOUT THAT. WHAT POPULATION? JAPAN? EARTH?

ACTUALLY, THE POPULATION WE'RE TALKING ABOUT ISN'T PEOPLE—IT'S DATA.

HERE, LOOK AT THE TEA ROOM DATA AGAIN.

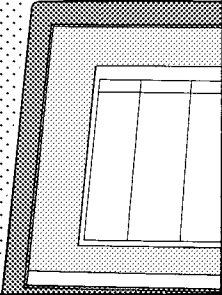

	High temp. (°C)	Iced tea orders
22nd (Mon.)	29	77
23rd (Tues.)	28	62
24th (Wed.)	34	93
25th (Thurs.)	31	84
26th (Fri.)	25	59
27th (Sat.)	29	64
28th (Sun.)	32	80
29th (Mon.)	31	75
30th (Tues.)	24	58
31st (Wed.)	33	91
1st (Thurs.)	25	51
2nd (Fri.)	31	73
3rd (Sat.)	26	65
4th (Sun.)	30	84

HOW MANY DAYS ARE THERE WITH A HIGH TEMPERATURE OF 31°C?



THE 25TH, 29TH, AND 2ND... SO THREE.



SO...

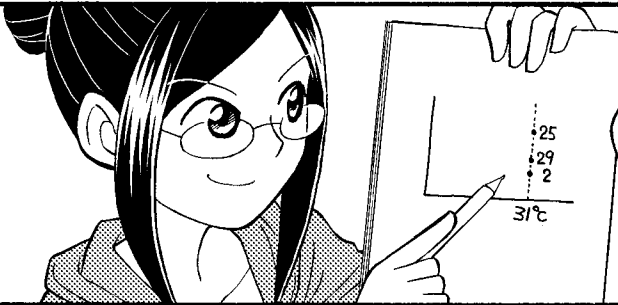

I CAN MAKE A CHART LIKE THIS FROM YOUR ANSWER.

NOW, CONSIDER THAT...

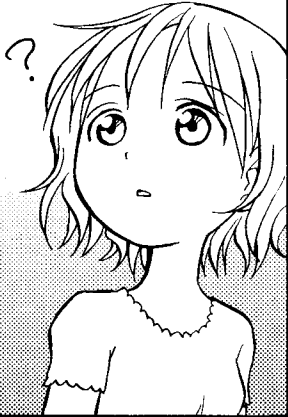

...THESE THREE DAYS ARE NOT THE ONLY DAYS IN HISTORY WITH A HIGH OF 31°C, ARE THEY?

THERE MUST HAVE BEEN MANY OTHERS IN THE PAST, AND THERE WILL BE MANY MORE IN THE FUTURE, RIGHT?

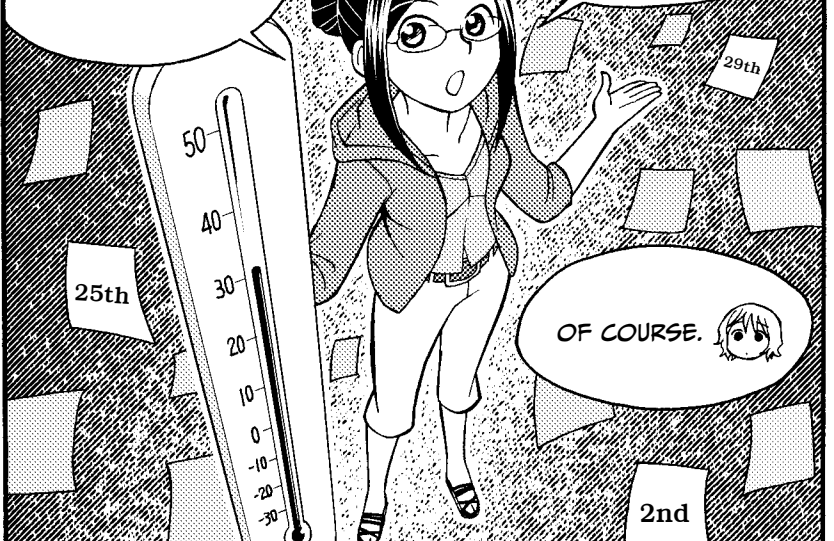

OF COURSE.



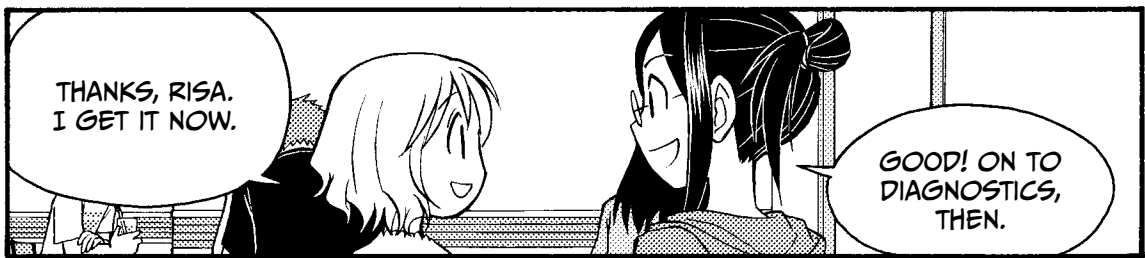
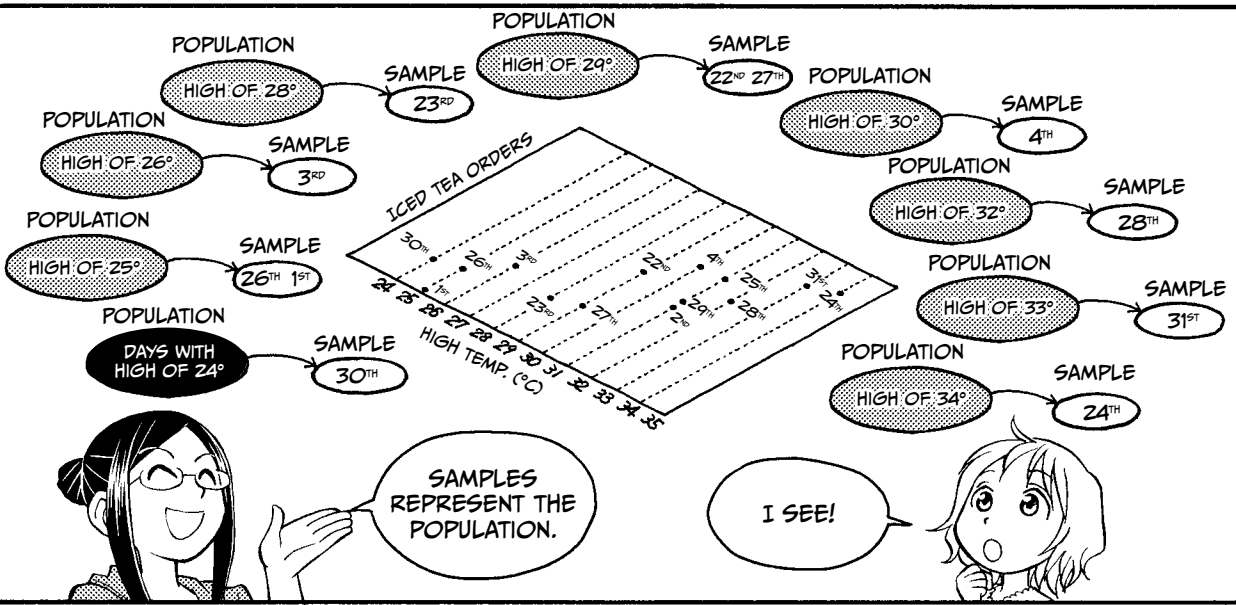
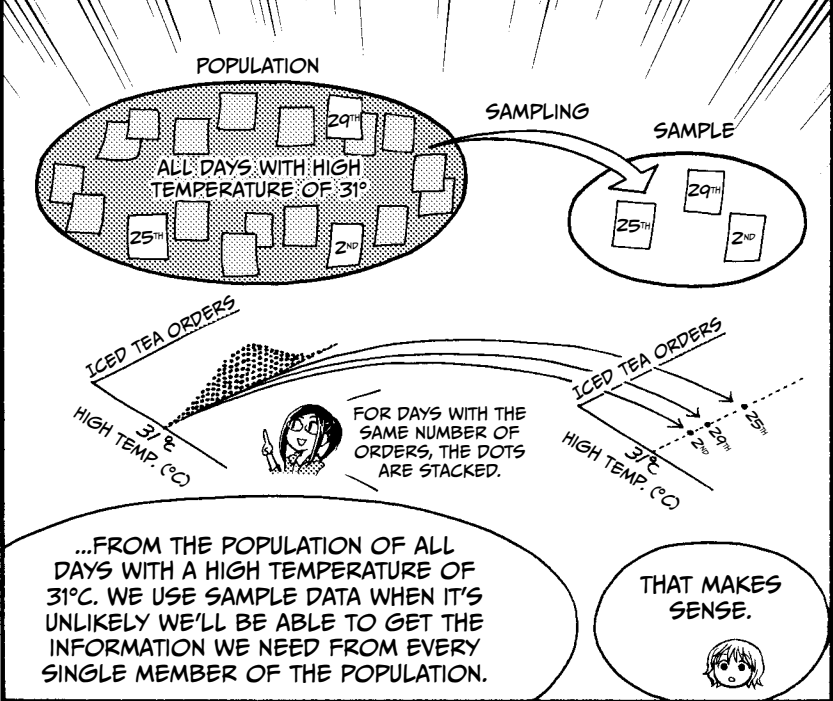

ASSUMPTIONS OF NORMALITY

A REGRESSION EQUATION IS MEANINGFUL ONLY IF A CERTAIN HYPOTHESIS IS VIABLE.

LIKE WHAT?

HERE IT IS:

ALTERNATIVE HYPOTHESIS

THE NUMBER OF ORDERS OF ICED TEA ON DAYS WITH TEMPERATURE $x^{\circ}\text{C}$ FOLLOWS A NORMAL DISTRIBUTION WITH MEAN $Ax+B$ AND STANDARD DEVIATION σ (SIGMA).

LET'S TAKE IT SLOW.
FIRST LOOK AT THE SHAPES ON THIS GRAPH.

ICED TEA ORDERS

$Ax+B$

SAME SHAPE

HIGH TEMP. ($^{\circ}\text{C}$)

THESE SHAPES REPRESENT THE ENTIRE POPULATION OF ICED TEA ORDERS FOR EACH HIGH TEMPERATURE. SINCE WE CAN'T POSSIBLY KNOW THE EXACT DISTRIBUTION FOR EACH TEMPERATURE, WE HAVE TO ASSUME THAT THEY MUST ALL BE THE SAME: A NORMAL, BELL-SHAPED CURVE.



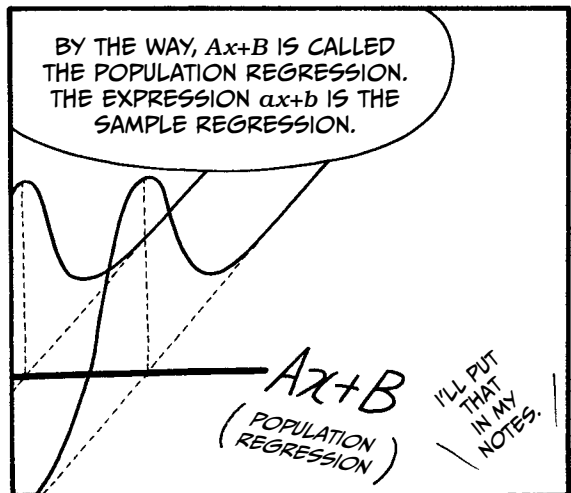
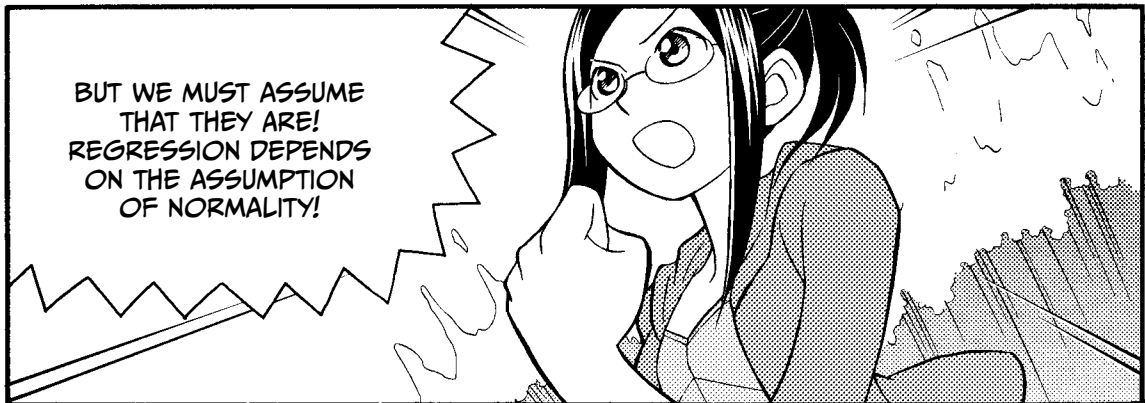
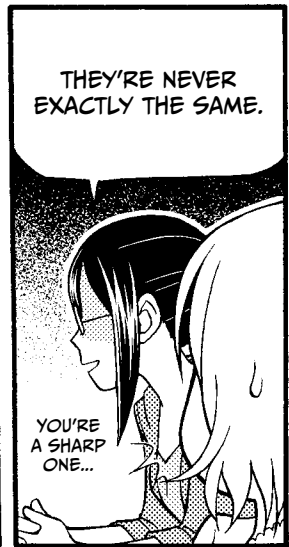
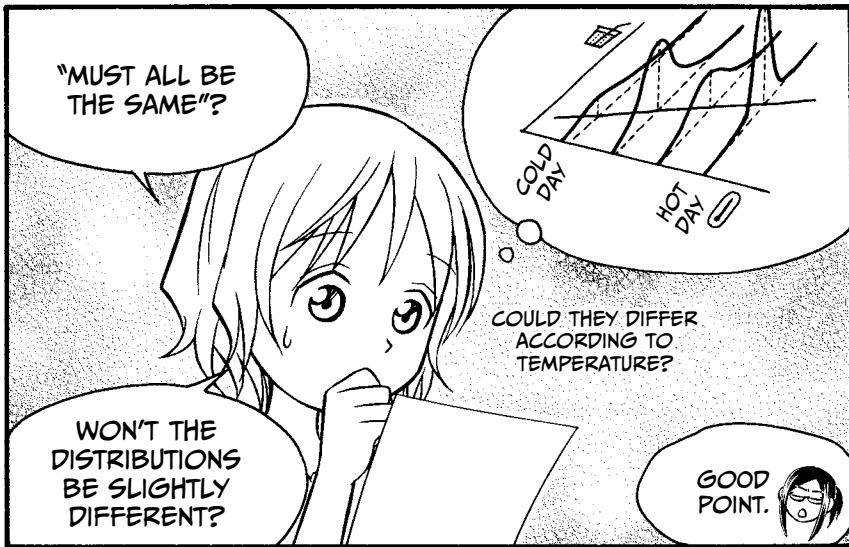

STEP 4: CONDUCT THE ANALYSIS OF VARIANCE.

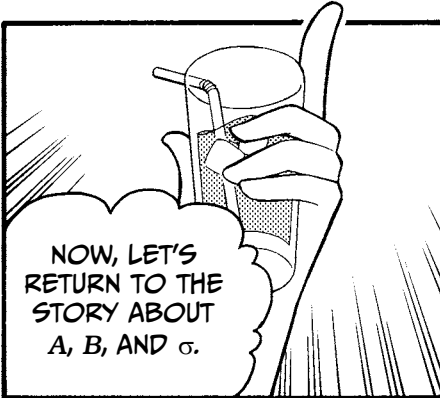
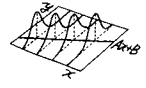

NOW, LET'S RETURN TO THE STORY ABOUT A, B, AND σ .

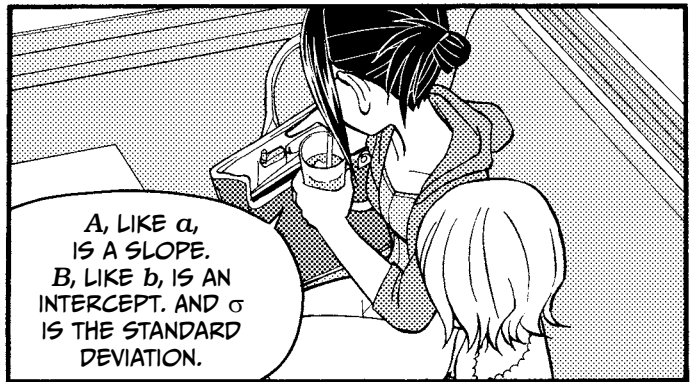

A, LIKE α , IS A SLOPE.
B, LIKE b , IS AN INTERCEPT. AND σ IS THE STANDARD DEVIATION.

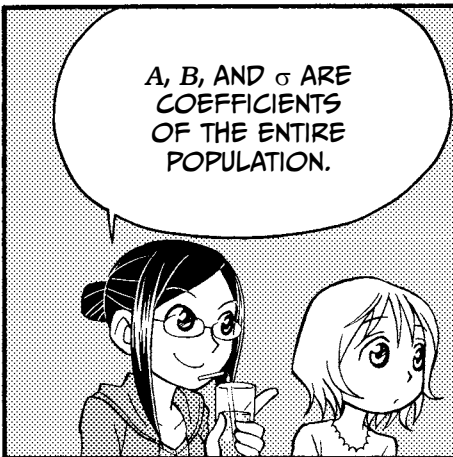

A, B, AND σ ARE COEFFICIENTS OF THE ENTIRE POPULATION.

IF THE REGRESSION EQUATION IS

$$y = ax + b$$

- a SHOULD BE CLOSE TO A
- b SHOULD BE CLOSE TO B
- $\frac{s_e}{\sqrt{\text{number of individuals} - 2}}$ SHOULD BE CLOSE TO σ

DO YOU RECALL a , b , AND THE STANDARD DEVIATION FOR OUR NORNS DATA?

WELL, THE REGRESSION EQUATION WAS $y = 3.7x - 36.4$, SO...

POPULATION REGRESSION IS ALSO NEAR HERE?

- A IS ABOUT 3.7
- B IS ABOUT -36.4
- σ IS ABOUT $\sqrt{\frac{391.1}{14-2}} = \sqrt{\frac{391.1}{12}} = 5.7$

IS THAT RIGHT?

PERFECT!

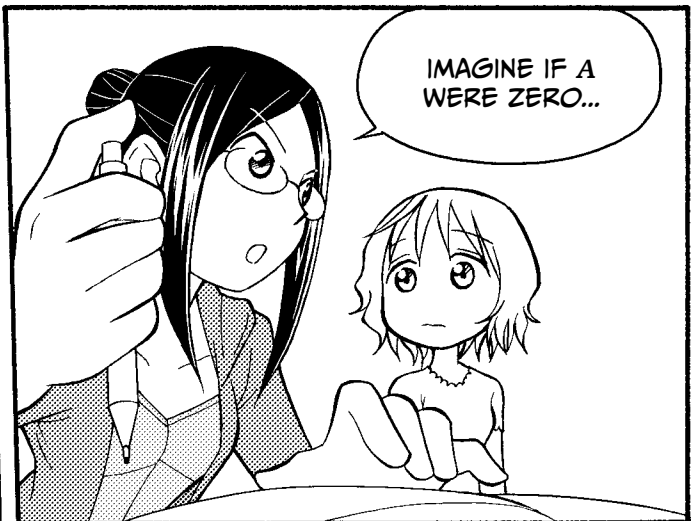
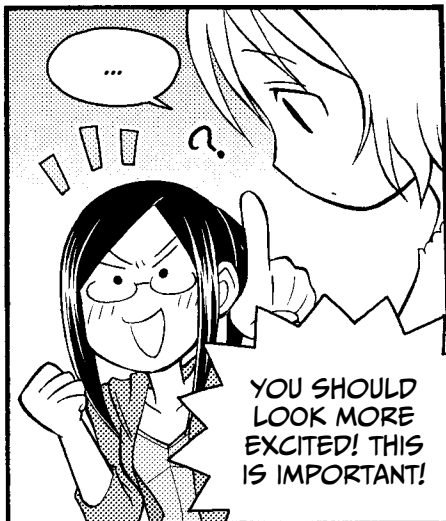
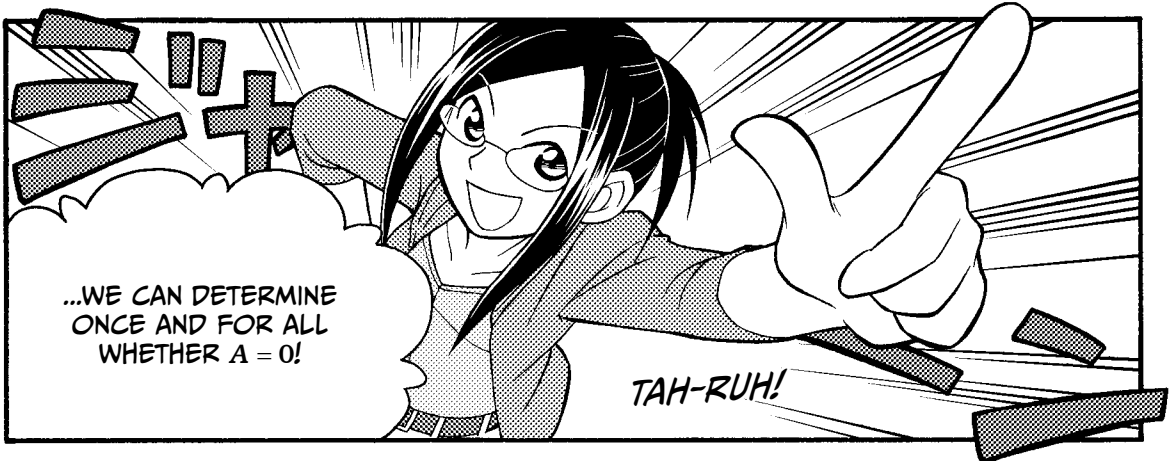
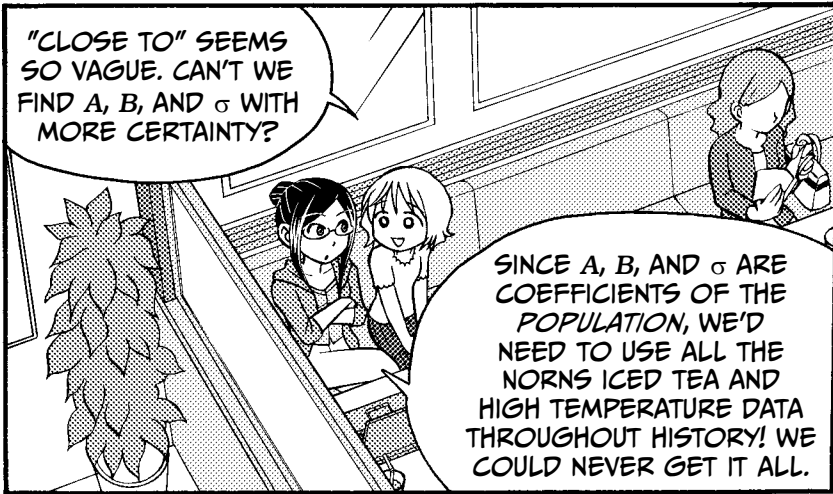

THAT WOULD MAKE THIS DREADED HYPOTHESIS TRUE!

NULL HYPOTHESIS

THE NUMBER OF ORDERS OF ICED TEA ON DAYS WITH HIGH TEMPERATURE x °C FOLLOWS A NORMAL DISTRIBUTION WITH MEAN B AND STANDARD DEVIATION σ . (A IS ABSENT!)

A IS GONE!

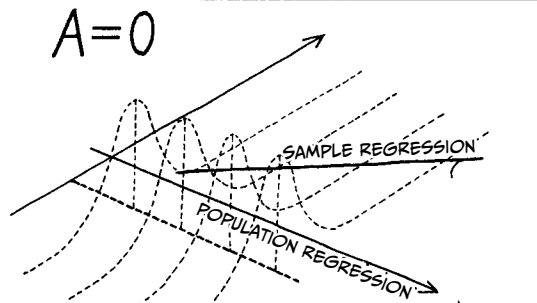
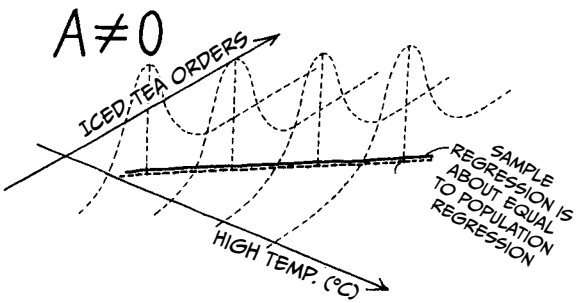

IF THE SLOPE $A = 0$, THE LINE IS HORIZONTAL. THAT MEANS ICED TEA ORDERS ARE THE SAME, NO MATTER WHAT THE HIGH TEMPERATURE IS!

THE TEMPERATURE DOESN'T MATTER!

HOW DO WE FIND OUT ABOUT A ?

ANOVA

WE CAN DO AN ANALYSIS OF VARIANCE (ANOVA)!

LET'S DO THE ANALYSIS AND SEE WHAT FATE HAS IN STORE FOR A .

THIS IS GETTING EXCITING.

THE STEPS OF ANOVA

Step 1	Define the population.	The population is “days with a high temperature of x degrees.”
Step 2	Set up a null hypothesis and an alternative hypothesis.	Null hypothesis is $A = 0$. Alternative hypothesis is $A \neq 0$.
Step 3	Select which hypothesis test to conduct.	We’ll use analysis of one-way variance.
Step 4	Choose the significance level.	We’ll use a significance level of .05.
Step 5	Calculate the test statistic from the sample data.	The test statistic is: $\left(\frac{1}{S_{xx}}\right) + \frac{S_e}{\text{number of individuals} - 2}$ Plug in the values from our sample regression equation: $\left(\frac{1}{129.7}\right) + \frac{391.1}{14 - 2} = 55.6$ The test statistic will follow an F distribution with first degree of freedom 1 and second degree of freedom 12 (number of individuals minus 2), if the null hypothesis is true.
Step 6	Determine whether the p -value for the test statistic obtained in Step 5 is smaller than the significance level.	At significance level .05, with d_1 being 1 and d_2 being 12, the critical value is 4.7472. Our test statistic is 55.6.
Step 7	Decide whether you can reject the null hypothesis.	Since our test statistic is greater than the critical value, we reject the null hypothesis.

THE F STATISTIC LETS US TEST THE SLOPE OF THE LINE BY LOOKING AT VARIANCE. IF THE VARIATION AROUND THE LINE IS MUCH SMALLER THAN THE TOTAL VARIANCE OF Y , THAT'S EVIDENCE THAT THE LINE ACCOUNTS FOR Y 'S VARIATION, AND THE STATISTIC WILL BE LARGE. IF THE RATIO IS SMALL, THE LINE DOESN'T ACCOUNT FOR MUCH VARIATION IN Y , AND PROBABLY ISN'T USEFUL!

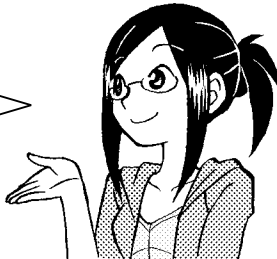

SO $A \neq 0$,
WHAT A RELIEF!

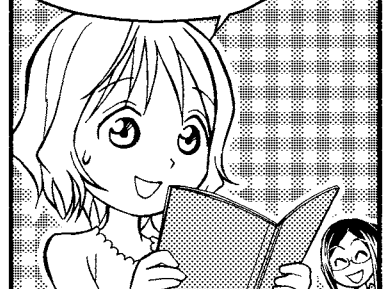

STEP 5: CALCULATE THE CONFIDENCE INTERVALS.

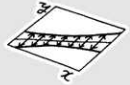

NOW, LET'S TAKE A CLOSER LOOK AT HOW WELL OUR REGRESSION EQUATION REPRESENTS THE POPULATION.

OKAY, I'M READY!

IN THE POPULATION...

...LOTS OF DAYS HAVE A HIGH OF 31°C, AND THE NUMBER OF ICED TEA ORDERS ON THOSE DAYS VARIES. OUR REGRESSION EQUATION PREDICTS ONLY ONE VALUE FOR ICED TEA ORDERS AT THAT TEMPERATURE.

HOW DO WE KNOW THAT IT'S THE RIGHT VALUE?

WE CAN'T KNOW FOR SURE. WE CHOOSE THE MOST LIKELY VALUE: THE POPULATION MEAN.

IF THE POPULATION HAS A NORMAL DISTRIBUTION...

DAYS WITH A HIGH OF 31°C CAN EXPECT APPROXIMATELY THE MEAN NUMBER OF ICED TEA ORDERS. WE CAN'T KNOW THE EXACT MEAN, BUT WE CAN ESTIMATE A RANGE IN WHICH IT MIGHT FALL.

HUH? THE RANGES DIFFER, DEPENDING ON THE VALUE OF x !

WE CALCULATE AN INTERVAL FOR EACH TEMPERATURE.

AS YOU NOTICED, THE WIDTH VARIES. IT'S SMALLER NEAR \bar{x} , WHICH IS THE AVERAGE HIGH TEMPERATURE VALUE.

EVEN THIS INTERVAL ISN'T ABSOLUTELY GUARANTEED TO CONTAIN THE TRUE POPULATION MEAN. OUR CONFIDENCE IS DETERMINED BY THE CONFIDENCE COEFFICIENT.

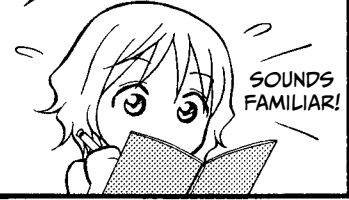
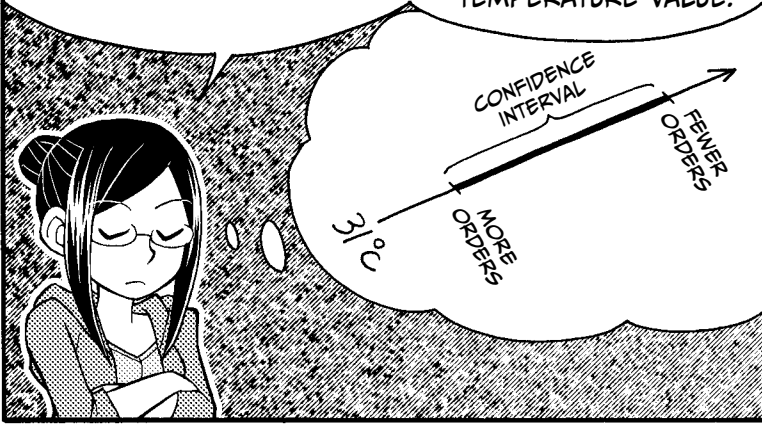

NOW, CONFIDENCE...

...IS NO ORDINARY COEFFICIENT.

THERE IS NO EQUATION TO CALCULATE IT, NO SET RULE.

YOU CHOOSE THE CONFIDENCE COEFFICIENT, AND YOU CAN MAKE IT ANY PERCENTAGE YOU WANT.

I WILL MAKE IT 42%.



WHEN CALCULATING A CONFIDENCE INTERVAL, YOU CHOOSE THE CONFIDENCE COEFFICIENT FIRST.

YOU WOULD THEN SAY "A 42% CONFIDENCE INTERVAL FOR ICED TEA ORDERS WHEN THE TEMPERATURE IS 31°C IS 30 TO 35 ORDERS," FOR EXAMPLE!



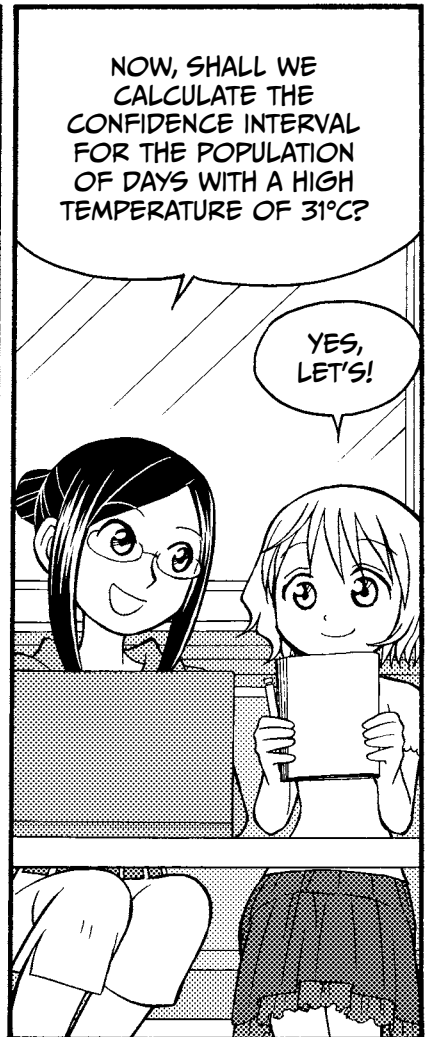
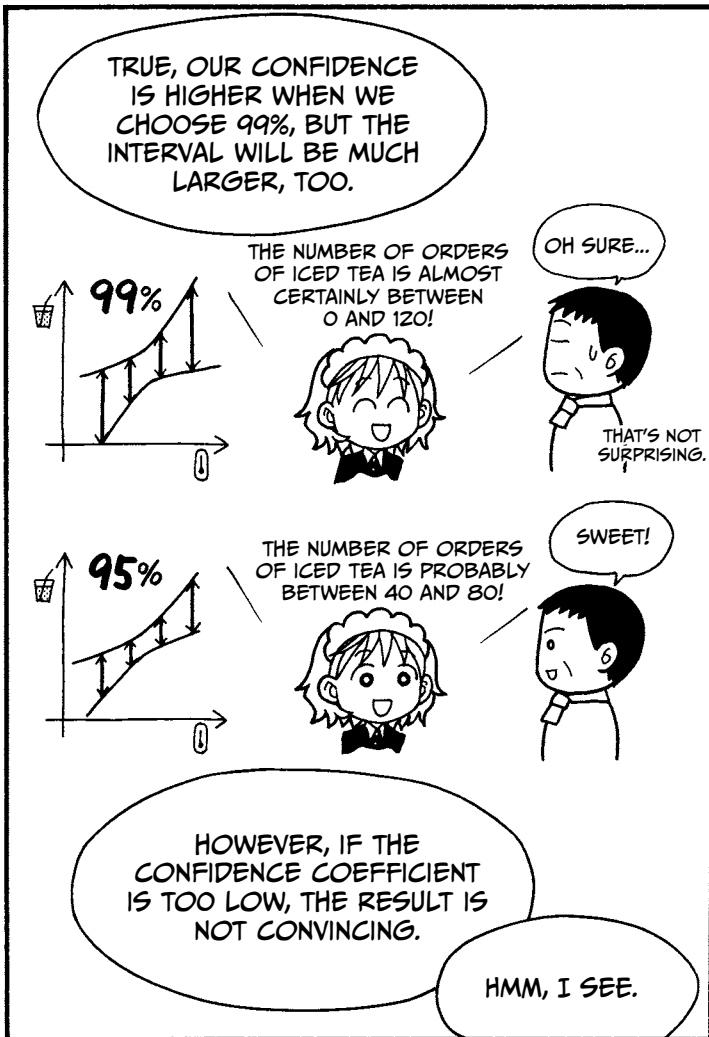
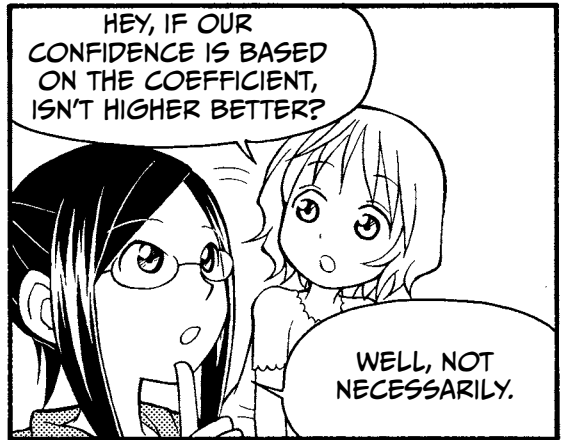
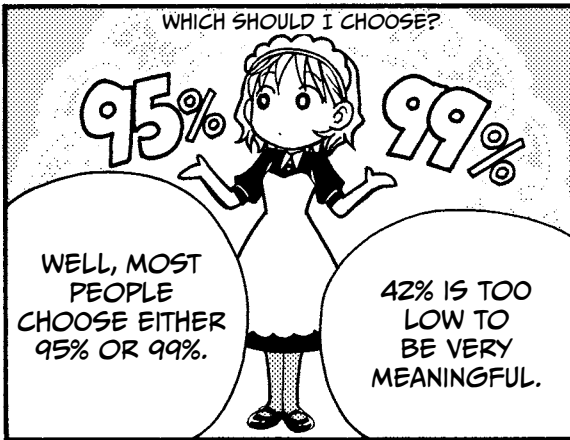

HERE'S HOW TO CALCULATE A 95% CONFIDENCE INTERVAL FOR ICED TEA ORDERS ON DAYS WITH A HIGH OF 31°C.



This is the confidence interval.

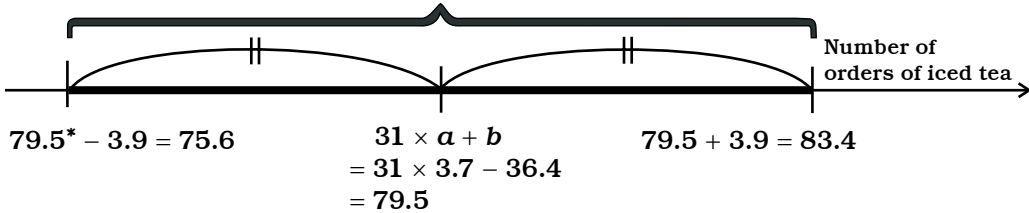

Distance from the estimated mean is

$$\begin{aligned}
 & \sqrt{F(1, n-2; .05) \times \left(\frac{1}{n} + \frac{(x_0 - \bar{x})^2}{S_{xx}} \right) \times \frac{S_e}{n-2}} \\
 &= \sqrt{F(1, 14-2; .05) \times \left(\frac{1}{14} + \frac{(31 - 29.1)^2}{129.7} \right) \times \frac{391.1}{14-2}} \\
 &= 3.9
 \end{aligned}$$

where n is the number of data points in our sample and F is a ratio of two chi-squared distributions, as described on page 57.

TO CALCULATE A 99% CONFIDENCE INTERVAL,
JUST CHANGE

$$F(1, 14 - 2; .05) = 4.7$$

TO

$$F(1, 14 - 2; .01) = 9.3$$

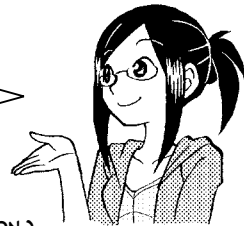

(REFER TO PAGE 58 FOR AN EXPLANATION OF $F(1, n-2; .05) = 4.7$, AND SO ON.)

* THE VALUE 79.5 WAS CALCULATED USING UNROUNDED NUMBERS.

SO WE ARE 95% SURE THAT, IF WE LOOK AT THE POPULATION OF DAYS WITH A HIGH OF 31°C, THE MEAN NUMBER OF ICED TEA ORDERS IS BETWEEN 76 AND 83.

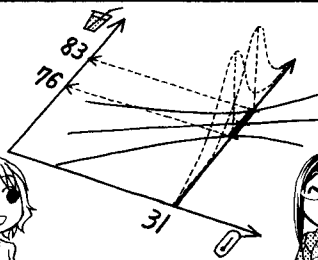

EXACTLY!

STEP 6: MAKE A PREDICTION!

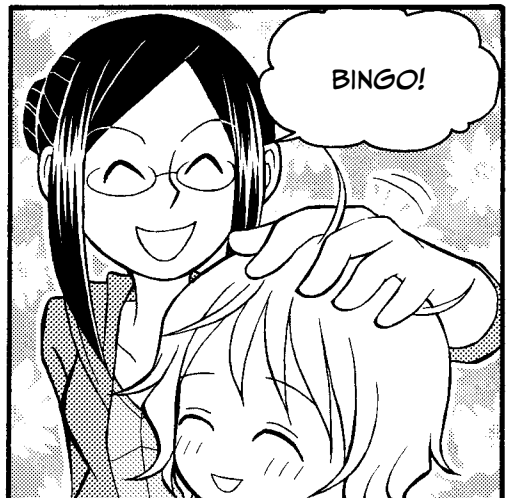
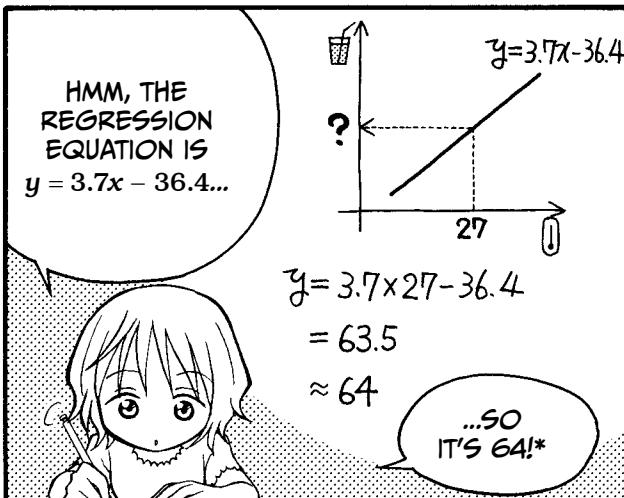
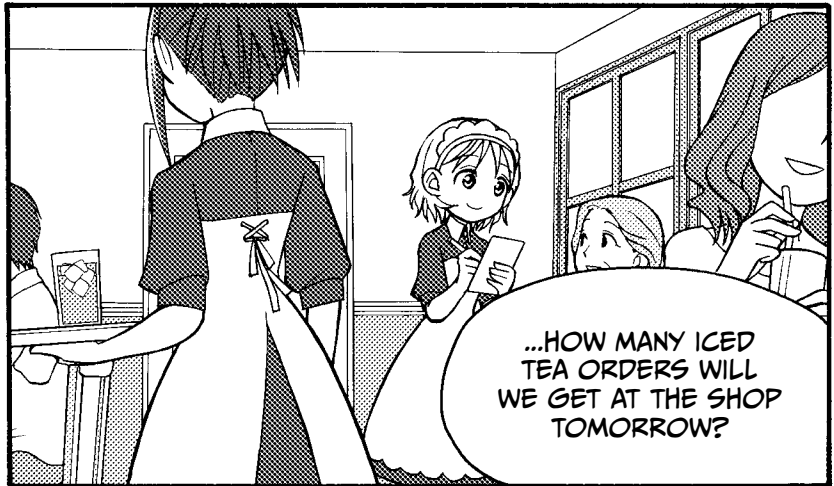
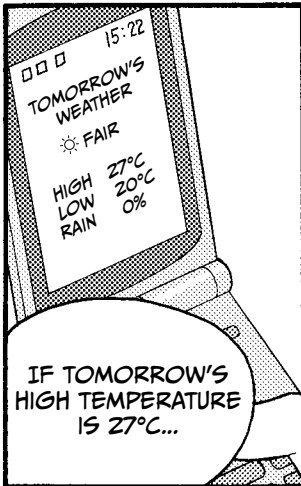
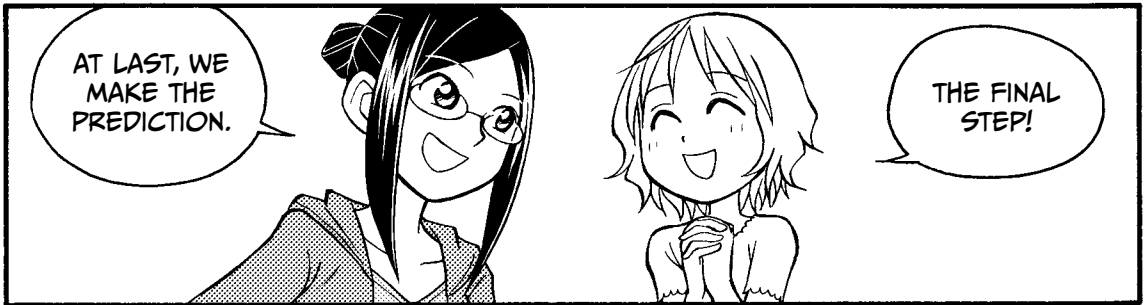
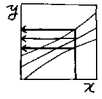

* THIS CALCULATION WAS PERFORMED USING ROUNDED FIGURES. IF YOU'RE DOING THE CALCULATION WITH THE FULL, UNROUNDED FIGURES, YOU SHOULD GET 64.6.

BUT WILL THERE BE EXACTLY 64 ORDERS?

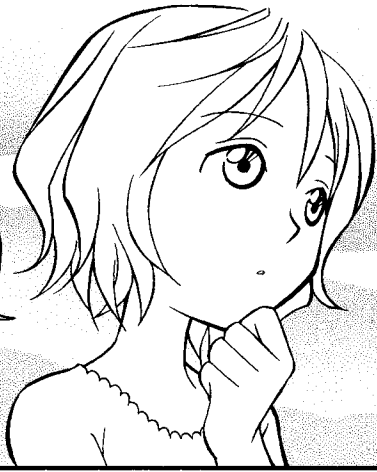

HOW CAN WE POSSIBLY KNOW FOR SURE?

THAT'S A GREAT QUESTION.

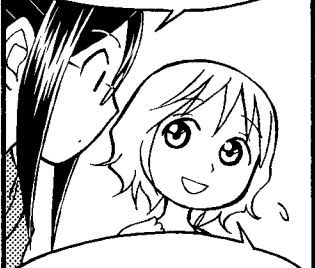

WE SHOULD GET CLOSE TO 64 ORDERS BECAUSE THE VALUE OF R^2 IS 0.8225, BUT... HOW CLOSE?

WE'LL MAKE A PREDICTION INTERVAL!

WE'LL PICK A COEFFICIENT AND THEN CALCULATE A RANGE IN WHICH ICED TEA ORDERS WILL MOST LIKELY FALL.

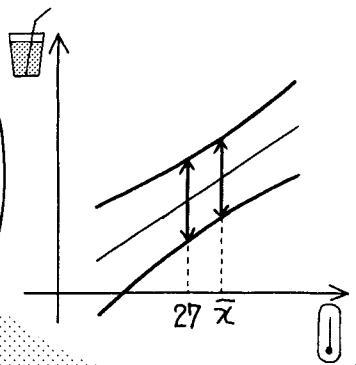

DIDN'T WE JUST DO THAT?



NOT QUITE. BEFORE, WE WERE PREDICTING THE MEAN NUMBER OF ICED TEA ORDERS FOR THE POPULATION OF DAYS WITH A CERTAIN HIGH TEMPERATURE, BUT NOW WE'RE PREDICTING THE LIKELY NUMBER OF ICED TEA ORDERS ON A GIVEN DAY WITH A CERTAIN TEMPERATURE.

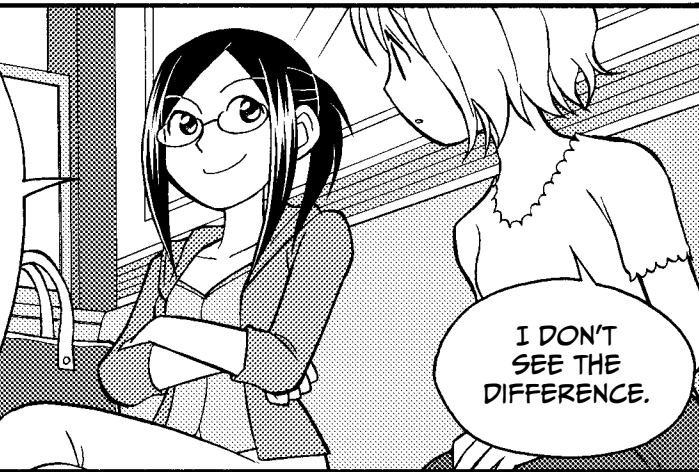

I DON'T SEE THE DIFFERENCE.

WHAT'S THE POPULATION LIKE?

$y = ax + b$

CONFIDENCE INTERVALS HELP US ASSESS THE POPULATION.

HOW MANY ORDERS WILL I GET?

$y = ax + b$

27

PREDICTION INTERVALS GIVE A PROBABLE RANGE OF FUTURE VALUES.

THE PREDICTION INTERVAL LOOKS LIKE A CONFIDENCE INTERVAL, BUT IT'S NOT THE SAME.

PREDICTION INTERVAL

MINIMUM ORDERS

27°C

MAXIMUM ORDERS

AS WITH A CONFIDENCE INTERVAL, WE NEED TO CHOOSE THE CONFIDENCE COEFFICIENT BEFORE WE CAN DO THE CALCULATION. AGAIN, 95% AND 99% ARE POPULAR.

I JUST CALCULATED AN INTERVAL, SO THIS SHOULD BE A SNAP.

THE CALCULATION IS VERY SIMILAR, WITH ONE IMPORTANT DIFFERENCE...

THE PREDICTION INTERVAL WILL BE WIDER BECAUSE IT COVERS THE RANGE OF ALL EXPECTED VALUES, NOT JUST WHERE THE MEAN SHOULD BE.

CONFIDENCE INTERVAL

PREDICTION INTERVAL

REGRESSION EQUATION

χ

THE FUTURE IS ALWAYS SURPRISING.

NOW, TRY CALCULATING THE PREDICTION INTERVAL FOR 27°C.

NO SWEAT!

HERE'S HOW WE CALCULATE A 95% PREDICTION INTERVAL FOR TOMORROW'S ICED TEA SALES.



This is the prediction interval.

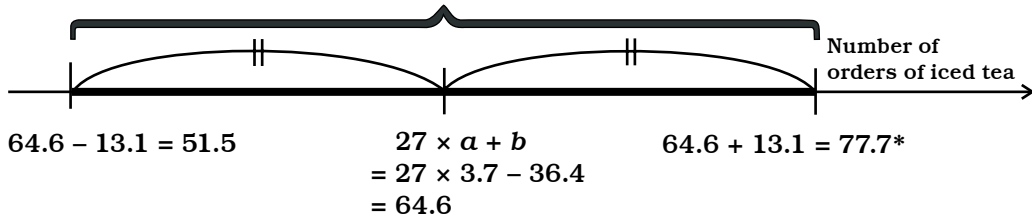

Distance from the estimated value is

$$\sqrt{F(1, n - 2; .05) \times \left(1 + \frac{1}{n} + \frac{(x_0 - \bar{x})^2}{S_{xx}}\right) \times \frac{S_e}{n - 2}}$$

$$= \sqrt{F(1, 14 - 2; .05) \times \left(1 + \frac{1}{14} + \frac{(27 - 29.1)^2}{129.7}\right) \times \frac{391.1}{14 - 2}}$$

$$= 13.1$$

THE ESTIMATED NUMBER OF TEA ORDERS WE CALCULATED EARLIER (ON PAGE 95) WAS ROUNDED, BUT WE'VE USED THE NUMBER OF TEA ORDERS ESTIMATED USING UNROUNDED NUMBERS, 64.6, HERE.

HERE WE USED THE F DISTRIBUTION TO FIND THE PREDICTION INTERVAL AND POPULATION REGRESSION. TYPICALLY, STATISTICIANS USE THE T DISTRIBUTION TO GET THE SAME RESULTS.

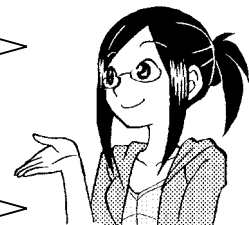

* THIS CALCULATION WAS PERFORMED USING THE ROUNDED NUMBERS SHOWN HERE. THE FULL, UNROUNDED CALCULATION RESULTS IN 77.6.

SO WE'RE 95% CONFIDENT THAT THE NUMBER OF ICED TEA ORDERS WILL BE BETWEEN 52 AND 78 WHEN THE HIGH TEMPERATURE FOR THAT DAY IS 27°C.

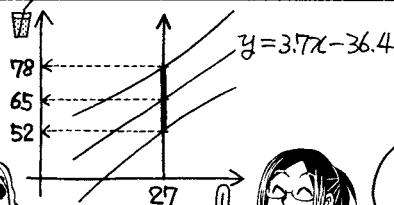

THAT'S THE IDEA!

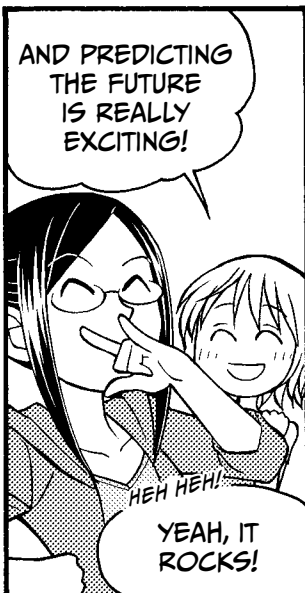
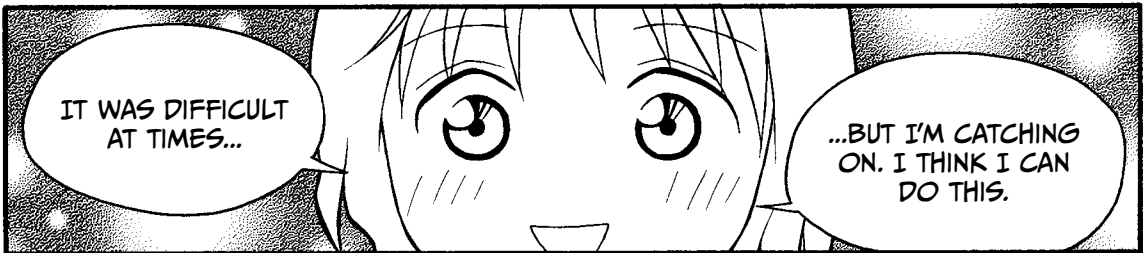
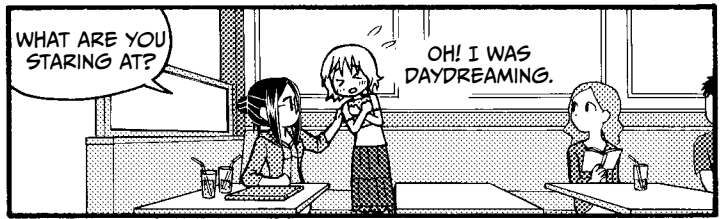
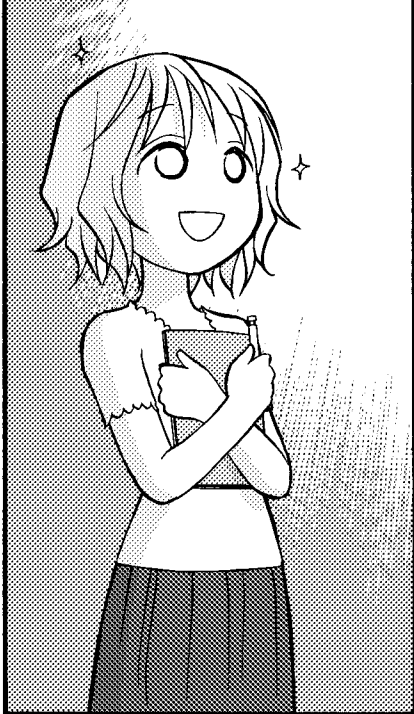

WHICH STEPS ARE NECESSARY?

Remember the regression analysis procedure introduced on page 68?

1. Draw a scatter plot of the independent variable versus the dependent variable. If the dots line up, the variables may be correlated.
2. Calculate the regression equation.
3. Calculate the correlation coefficient (R) and assess our population and assumptions.
4. Conduct the analysis of variance.
5. Calculate the confidence intervals.
6. Make a prediction!

In this chapter, we walked through each of the six steps, but it isn't always necessary to do every step. Recall the example of Miu's age and height on page 25.

- Fact: There is only one Miu in this world.
- Fact: Miu's height when she was 10 years old was 137.5 cm.

Given these two facts, it makes no sense to say that "Miu's height when she was 10 years old follows a normal distribution with mean $Ax + B$ and standard deviation σ ." In other words, it's nonsense to analyze the population of Miu's heights at 10 years old. She was just one height, and we know what her height was.

In regression analysis, we either analyze the entire population or, much more commonly, analyze a sample of the larger population. When you analyze a sample, you should perform all the steps. However, since Steps 4 and 5 assess how well the sample represents the population, you can skip them if you're using data from an entire population instead of just a sample.

NOTE We use the term *statistic* to describe a measurement of a characteristic from a sample, like a sample mean, and *parameter* to describe a measurement that comes from a population, like a population mean or coefficient.

STANDARDIZED RESIDUAL

Remember that a *residual* is the difference between the *measured* value and the value *estimated* with the regression equation. The *standardized residual* is the residual divided by its estimated standard deviation. We use the standardized residual to assess whether a particular measurement deviates significantly from

the trend. For example, say a group of thirsty joggers stopped by Norns on the 4th, meaning that though iced tea orders were expected to be about 76 based on that day's high temperature, customers actually placed 84 orders for iced tea. Such an event would result in a large standardized residual.

Standardized residuals are calculated by dividing each residual by an estimate of its standard deviation, which is calculated using the residual sum of squares. The calculation is a little complicated, and most statistics software does it automatically, so we won't go into the details of the calculation here.

Table 2-1 shows the standardized residual for the Norns data used in this chapter.

TABLE 2-1: CALCULATING THE STANDARDIZED RESIDUAL

	High temperature x	Measured number of orders of iced tea y	Estimated number of orders of iced tea $\hat{y} = 3.7x - 36.4$	Residual $y - \hat{y}$	Standardized residual
22nd (Mon.)	29	77	72.0	5.0	0.9
23rd (Tues.)	28	62	68.3	-6.3	-1.2
24th (Wed.)	34	93	90.7	2.3	0.5
25th (Thurs.)	31	84	79.5	4.5	0.8
26th (Fri.)	25	59	57.1	1.9	0.4
27th (Sat.)	29	64	72.0	-8.0	-1.5
28th (Sun.)	32	80	83.3	-3.3	-0.6
29th (Mon.)	31	75	79.5	-4.5	-0.8
30th (Tues.)	24	58	53.3	4.7	1.0
31st (Wed.)	33	91	87.0	4.0	0.8
1st (Thurs.)	25	51	57.1	-6.1	-1.2
2nd (Fri.)	31	73	79.5	-6.5	-1.2
3rd (Sat.)	26	65	60.8	4.2	0.8
4th (Sun.)	30	84	75.8	8.2	1.5

As you can see, the standardized residual on the 4th is 1.5. If iced tea orders had been 76, as expected, the standardized residual would have been 0.

Sometimes a measured value can deviate so much from the trend that it adversely affects the analysis. If the standardized residual is greater than 3 or less than -3, the measurement is considered an *outlier*. There are a number of ways to handle outliers, including removing them, changing them to a set value, or just keeping them in the analysis as is. To determine which approach is most appropriate, investigate the underlying cause of the outliers.

INTERPOLATION AND EXTRAPOLATION

If you look at the x values (high temperature) on page 64, you can see that the highest value is 34°C and the lowest value is 24°C. Using regression analysis, you can *interpolate* the number of iced tea orders on days with a high temperature between 24°C and 34°C and *extrapolate* the number of iced tea orders on days with a high below 24°C or above 34°C. In other words, extrapolation is the estimation of values that fall outside the range of your observed data.

Since we've only observed the trend between 24°C and 34°C, we don't know whether iced tea sales follow the same trend when the weather is extremely cold or extremely hot. Extrapolation is therefore less reliable than interpolation, and some statisticians avoid it entirely.

For everyday use, it's fine to extrapolate—as long as you're aware that your result isn't completely trustworthy. However, avoid using extrapolation in academic research or to estimate a value that's far beyond the scope of the measured data.

AUTOCORRELATION

The independent variable used in this chapter was high temperature; this is used to predict iced tea sales. In most places, it's unlikely that the high temperature will be 20°C one day and then shoot up to 30°C the next day. Normally, the temperature rises or drops gradually over a period of several days, so if the two variables are related, the number of iced tea orders should rise or drop gradually as well. Our assumption, however, has been that the deviation (error) values are random. Therefore, our predicted values do not change from day to day as smoothly as they might in real life.

When analyzing variables that may be affected by the passage of time, it's a good idea to check for autocorrelation. Autocorrelation occurs when the error is correlated over time, and it can indicate that you need to use a different type of regression model.

There's an index to describe autocorrelation—the *Durbin-Watson statistic*, which is calculated as follows:

$$d = \frac{\sum_{t=2}^T (e_t - e_{t-1})^2}{\sum_{t=1}^T e_t^2}$$

The equation can be read as “the sum of the square of each residual minus the previous residual, divided by the sum of each residual squared.” You can calculate the value of the Durbin-Watson statistic for the example in this chapter:

$$\frac{(-6.3 - 5.0)^2 + (2.3 - (-6.3))^2 + \dots + (8.2 - 4.2)^2}{5.0^2 + (-6.3)^2 + \dots + 8.2^2} = 1.8$$

The exact critical value of the Durbin-Watson test differs for each analysis, and you can use a table to find it, but generally we use 1 as a cutoff: a result less than 1 may indicate the presence of autocorrelation. This result is close to 2, so we can conclude that there is no autocorrelation in our example.

NONLINEAR REGRESSION

On page 66, Risa said:



THE GOAL OF REGRESSION ANALYSIS IS TO OBTAIN THE REGRESSION EQUATION IN THE FORM OF
 $y = ax + b.$

This equation is linear, but regression equations don't have to be linear. For example, these equations may also be used as regression equations:

- $y = \frac{a}{x} + b$
- $y = a\sqrt{x} + b$
- $y = ax^2 + bx + c$
- $y = a \times \log x + b$

The regression equation for Miu's age and height introduced on page 26 is actually in the form of $y = \frac{a}{x} + b$ rather than $y = ax + b$.

Of course, this raises the question of which type of equation you should choose when performing regression analysis on your own data. Below are some steps that can help you decide.

1. Draw a scatter plot of the data points, with the dependent variable values on the x-axis and the independent variable values on the y-axis. Examine the relationship between the variables suggested by the spread of the dots: Are they in roughly a straight line? Do they fall along a curve? If the latter, what is the shape of the curve?
2. Try the regression equation suggested by the shape in the variables plotted in Step 1. Plot the residuals (or standardized residuals) on the y-axis and the independent variable on the x-axis. The residuals should appear to be random, so if there is an obvious pattern in the residuals, like a curved shape, this suggests that the regression equation doesn't match the shape of the relationship.
3. If the residuals plot from Step 2 shows a pattern in the residuals, try a different regression equation and repeat Step 2. Try the shapes of several regression equations and pick one that appears to most closely match the data. It's usually best to pick the simplest equation that fits the data well.

TRANSFORMING NONLINEAR EQUATIONS INTO LINEAR EQUATIONS

There's another way to deal with nonlinear equations: simply turn them into linear equations. For an example, look at the equation for Miu's age and height (from page 26):

$$y = -\frac{326.6}{x} + 173.3$$

You can turn this into a linear equation. Remember:

$$\text{If } \frac{1}{x} = X, \text{ then } \frac{1}{X} = x.$$

So we'll define a new variable X , set it equal to $\frac{1}{x}$, and use X in the normal $y = aX + b$ regression equation. As shown on page 76, the value of a and b in the regression equation $y = aX + b$ can be calculated as follows:

$$\begin{cases} a = \frac{S_{xy}}{S_{xx}} \\ b = \bar{y} - \bar{X}a \end{cases}$$

We continue with the analysis as usual. See Table 2-2.

TALBE 2-2: CALCULATING THE REGRESSION EQUATION

Age x	$\frac{1}{\text{age}}$ $\frac{1}{x} = X$	Height y	$(X - \bar{X})$	$y - \bar{y}$	$(X - \bar{X})^2$	$(y - \bar{y})^2$	$(X - \bar{X})(y - \bar{y})$	
4	0.2500	100.1	0.1428	-38.1625	0.0204	1456.3764	-5.4515	
5	0.2000	107.2	0.0928	-31.0625	0.0086	964.8789	-2.8841	
6	0.1667	114.1	0.0595	-24.1625	0.0035	583.8264	-1.4381	
7	0.1429	121.7	0.0357	-16.5625	0.0013	274.3164	-0.5914	
8	0.1250	126.8	0.0178	-11.4625	0.0003	131.3889	-0.2046	
9	0.1111	130.9	0.0040	-7.3625	0.0000	54.2064	-0.0292	
10	0.1000	137.5	-0.0072	-0.7625	0.0001	0.5814	-0.0055	
11	0.0909	143.2	-0.0162	4.9375	0.0003	24.3789	-0.0802	
12	0.0833	149.4	-0.0238	11.1375	0.0006	124.0439	-0.2653	
13	0.0769	151.6	-0.0302	13.3375	0.0009	177.889	-0.4032	
14	0.0714	154.0	-0.0357	15.7375	0.0013	247.6689	-0.5622	
15	0.0667	154.6	-0.0405	16.3375	0.0016	266.9139	-0.6614	
16	0.0625	155.0	-0.0447	16.7375	0.0020	280.1439	-0.7473	
17	0.0588	155.1	-0.0483	16.8375	0.0023	283.5014	-0.8137	
18	0.0556	155.3	-0.0516	17.0375	0.0027	290.2764	-0.8790	
19	0.0526	155.7	-0.0545	17.4375	0.0030	304.0664	-0.9507	
Sum	184	1.7144	2212.2	0.0000	0.0000	0.0489	5464.4575	-15.9563
Average	11.5	0.1072	138.3					

According to the table:

$$\begin{cases} a = \frac{S_{xy}}{S_{xx}} = \frac{-15.9563}{0.0489} = -326.6^* \\ b = \bar{y} - \bar{X}a = 138.2625 - 0.1072 \times (-326.6) = 173.3 \end{cases}$$

So the regression equation is this:

$$y = -326.6X + 173.3$$

\uparrow \uparrow
 height $\frac{1}{\text{age}}$

* If your result is slightly different from 326.6, the difference might be due to rounding. If so, it should be very small.

which is the same as this:

$$y = -\frac{326.6}{x} + 173.3$$

↑ ↑
height age

We've transformed our original, nonlinear equation into a linear one!

3

MULTIPLE REGRESSION ANALYSIS

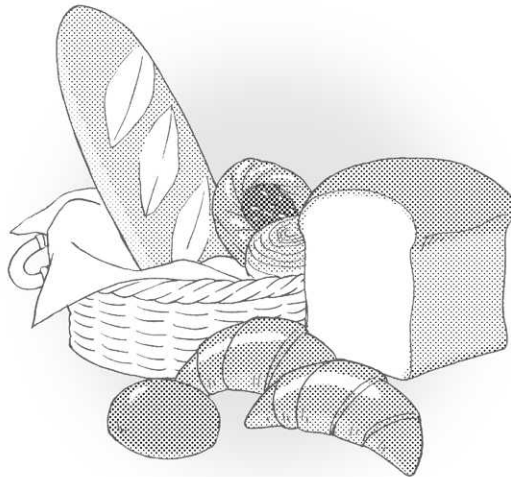

PREDICTING WITH MANY VARIABLES

THANKS FOR BRINGING THE DATA.

DON'T MENTION IT. IT'S NICE OF YOU TO HELP YOUR FRIEND.

WELL...

...I HAVE MY REASONS.

RISA...

OH, THAT'S HER.

PANT

WHEEZE

OVER HERE!

SORRY I'M LATE!

MY CLASS ENDED LATE. I RAN.

IT'S OKAY. WE JUST GOT HERE TOO.

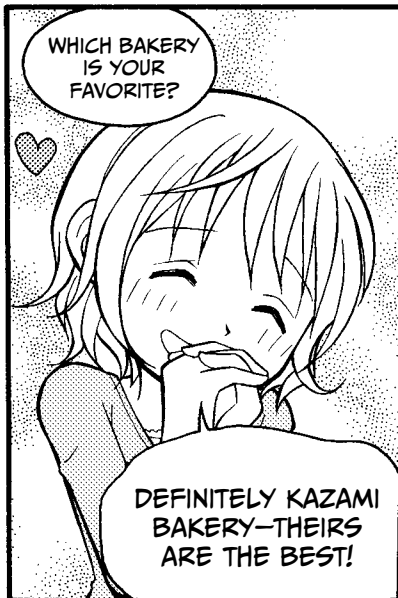
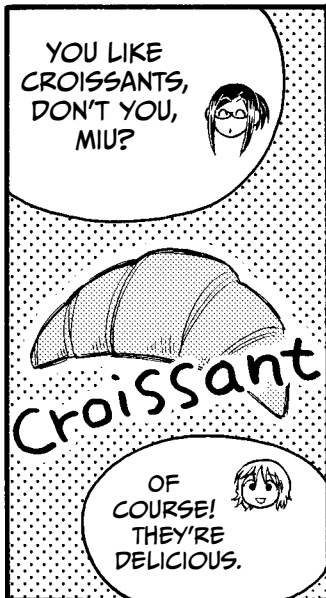
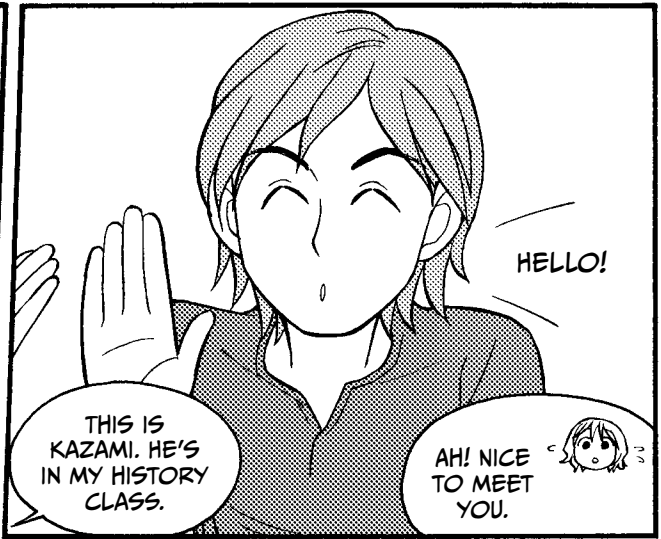
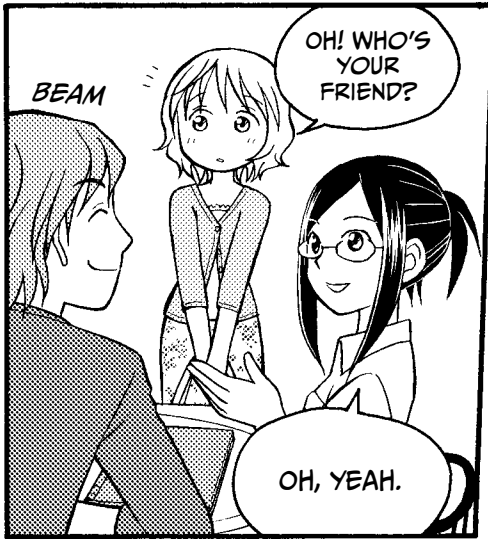

THEN YOU MUST BE...?

THE HEIR TO THE KAZAMI BAKERY EMPIRE!

RISA, DON'T BE DRAMATIC.

IT'S JUST A SMALL FAMILY BUSINESS.

BUT I SEE KAZAMI BAKERIES ALL OVER TOWN.

THERE ARE ONLY TEN RIGHT NOW, AND MOST OF THEM ARE HERE IN THE CITY.

YUMENOOKA
TERAI STATION
SONE
HASHIMOTO STATION
KIKYOU TOWN
POST OFFICE
SUIDOBASHI STATION
ROKUJO STATION
WAKABA RIVERSIDE
MISATO
ISEBASHI

NEW

WE'RE PLANNING TO OPEN A NEW ONE SOON.

SO TODAY...

WE'RE GOING TO PREDICT THE SALES OF THE NEW SHOP USING MULTIPLE REGRESSION ANALYSIS.

WOW!

ACCORDING TO MY NOTES, MULTIPLE REGRESSION ANALYSIS USES MORE THAN ONE FACTOR TO PREDICT AN OUTCOME.



THAT'S RIGHT.

IN SIMPLE REGRESSION ANALYSIS, WE USED ONE VARIABLE TO PREDICT THE VALUE OF ANOTHER VARIABLE.

IN MULTIPLE REGRESSION ANALYSIS, WE USE MORE THAN ONE VARIABLE TO PREDICT THE VALUE OF OUR OUTCOME VARIABLE.

MULTIPLE REGRESSION EQUATION

$$y = a_1x_1 + a_2x_2 + \dots + a_px_p + b$$

↑ ↑ ↑ ↑

OUTCOME VARIABLE PREDICTOR VARIABLES PARTIAL REGRESSION COEFFICIENTS

EVERY x VARIABLE HAS ITS OWN a , BUT THERE'S STILL JUST ONE INTERCEPT.

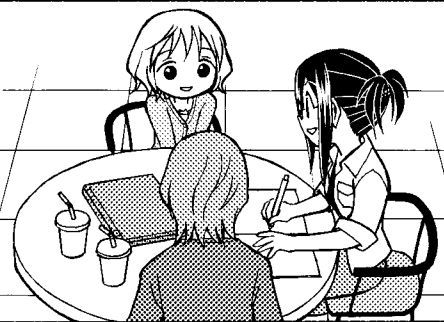

YEP. JUST ONE b .

AND JUST ONE OUTCOME VARIABLE, y . LIKE THIS, SEE?

I GET IT!

REGRESSION ANALYSIS

PREDICTOR VARIABLE

↓

OUTCOME VARIABLE

MULTIPLE REGRESSION ANALYSIS

PREDICTOR VARIABLE 1

PREDICTOR VARIABLE 2

.....

PREDICTOR VARIABLE P

↓ ↓ ↓

OUTCOME VARIABLE

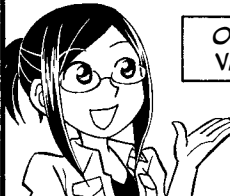
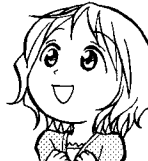
THE MULTIPLE REGRESSION EQUATION

ARE THE STEPS THE SAME AS IN SIMPLE REGRESSION ANALYSIS?

WELL...

CLICK!
THEY'RE SIMILAR— BUT NOT EXACTLY THE SAME.

MULTIPLE REGRESSION ANALYSIS PROCEDURE

STEP 1

DRAW A SCATTER PLOT OF EACH PREDICTOR VARIABLE AND THE OUTCOME VARIABLE TO SEE IF THEY APPEAR TO BE RELATED.

STEP 2

CALCULATE THE MULTIPLE REGRESSION EQUATION.

STEP 3

EXAMINE THE ACCURACY OF THE MULTIPLE REGRESSION EQUATION.

STEP 4

CONDUCT THE ANALYSIS OF VARIANCE (ANOVA) TEST.

STEP 5

CALCULATE CONFIDENCE INTERVALS FOR THE POPULATION.

STEP 6

MAKE A PREDICTION!

WE HAVE TO LOOK AT EACH PREDICTOR ALONE AND ALL OF THEM TOGETHER.

I'LL WRITE THAT DOWN.

STEP 1: DRAW A SCATTER PLOT OF EACH PREDICTOR VARIABLE AND THE OUTCOME VARIABLE TO SEE IF THEY APPEAR TO BE RELATED.

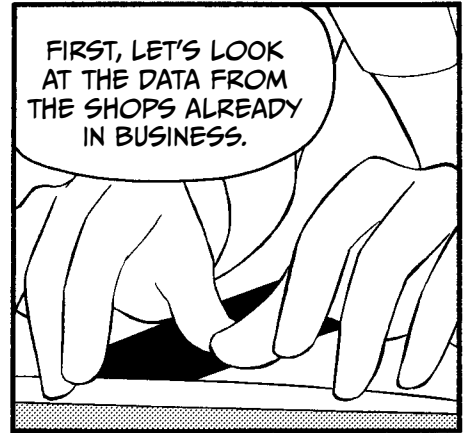
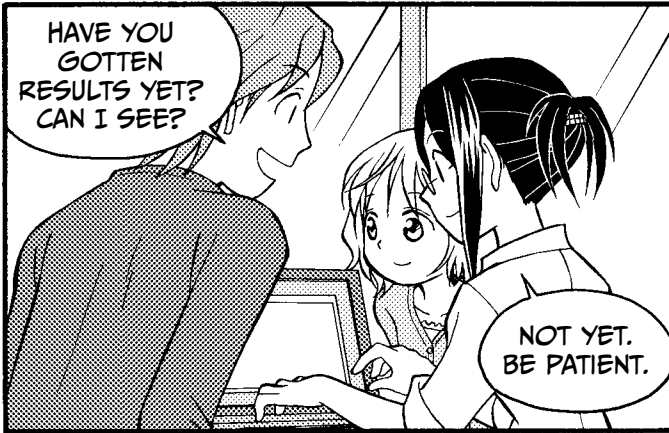

Bakery	Floor space of the shop (tsubo*)	Distance to the nearest station (meters)	Monthly sales (¥10,000)
Yumenooka Shop	10	80	469
Terai Station Shop	8	0	366
Sone Shop	8	200	371
Hashimoto Station Shop	5	200	208
Kikyou Town Shop	7	300	246
Post Office Shop	8	230	297
Suidobashi Station Shop	7	40	363
Rokujo Station Shop	9	0	436
Wakaba Riverside Shop	6	330	198
Misato Shop	9	180	364

* 1 tsubo is about 36 square feet.



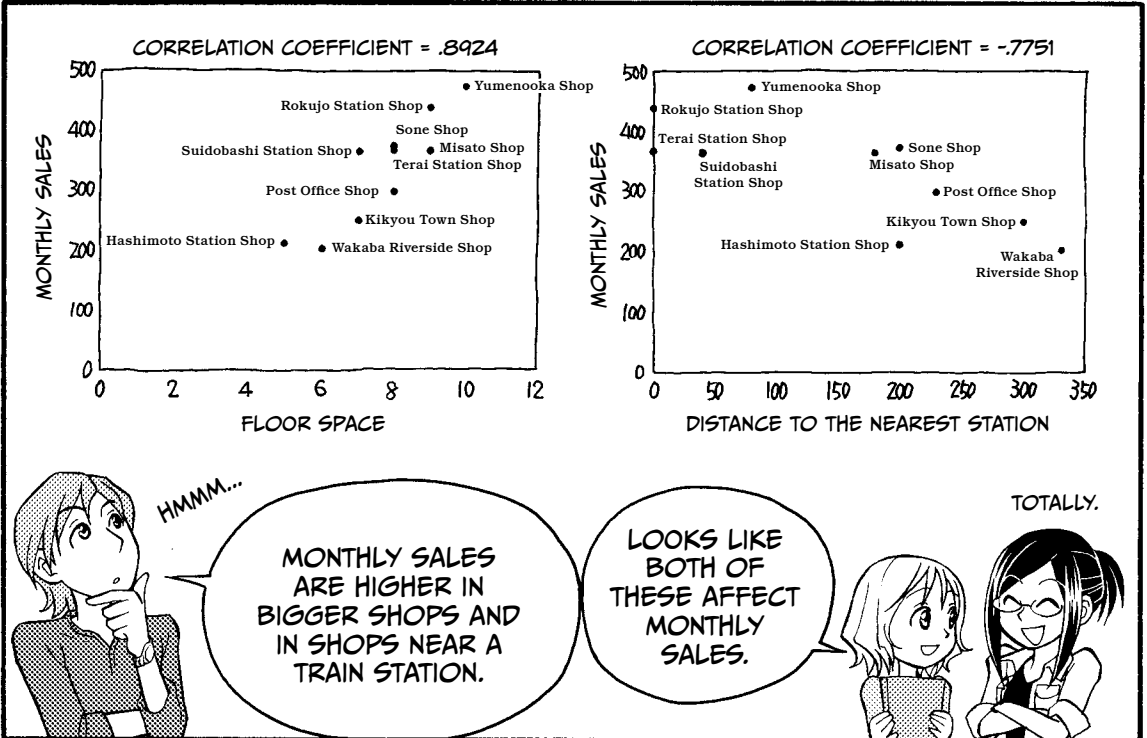
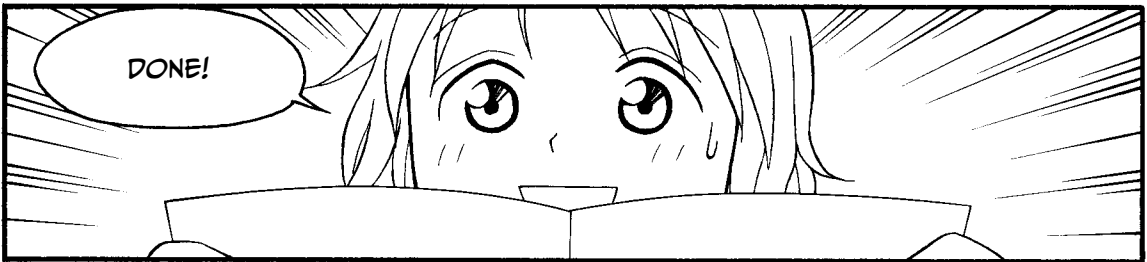
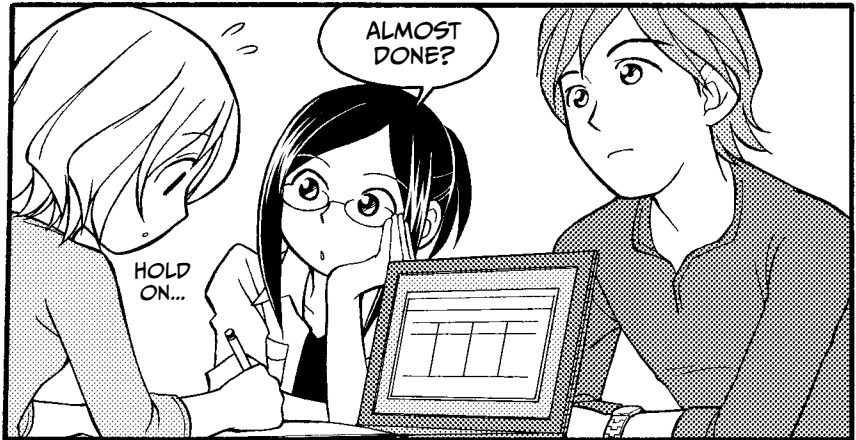
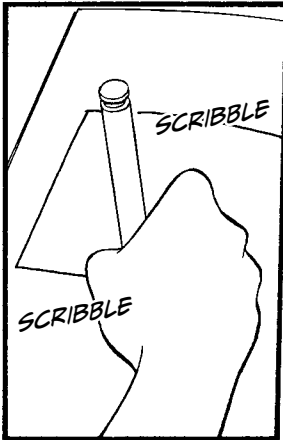

STEP 2: CALCULATE THE MULTIPLE REGRESSION EQUATION.

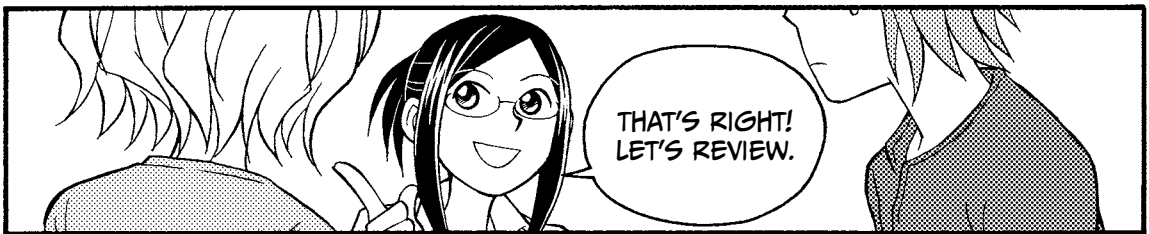
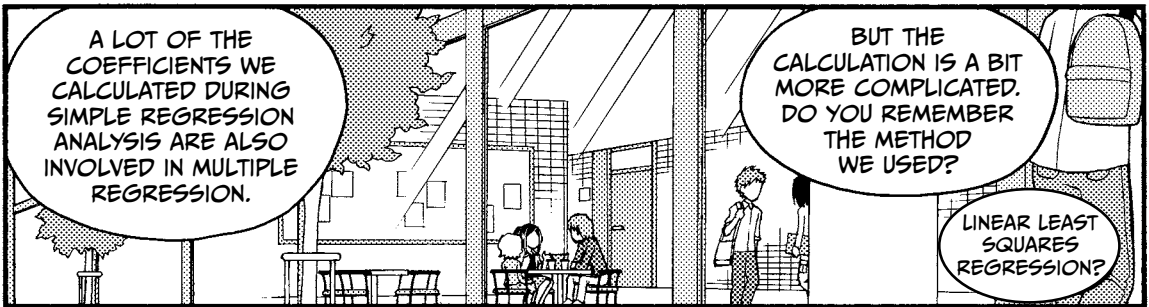

FIRST GET THE RESIDUAL SUM OF SQUARES, S_e .

$$S_e = \{469 - (a_1 \times 10 + a_2 \times 80 + b)\}^2 + \{366 - (a_1 \times 8 + a_2 \times 0 + b)\}^2 + \dots + \{364 - (a_1 \times 9 + a_2 \times 180 + b)\}^2$$

THEN DIFFERENTIATE BY a_1 , a_2 , AND b AND SET THE EQUATION EQUAL TO ZERO. FIND THE VALUES OF a_1 , a_2 , AND b THAT MAKE S_e AS SMALL AS POSSIBLE...

$$\frac{dS_e}{da_1} = 2(-10)\{469 - (a_1 \times 10 + a_2 \times 80 + b)\} + 2(-8)\{366 - (a_1 \times 8 + a_2 \times 0 + b)\} + \dots + 2(-9)\{364 - (a_1 \times 9 + a_2 \times 180 + b)\} = 0$$

$$\frac{dS_e}{da_2} = 2(-80)\{469 - (a_1 \times 10 + a_2 \times 80 + b)\} + 2(-0)\{366 - (a_1 \times 8 + a_2 \times 0 + b)\} + \dots + 2(-180)\{364 - (a_1 \times 9 + a_2 \times 180 + b)\} = 0$$

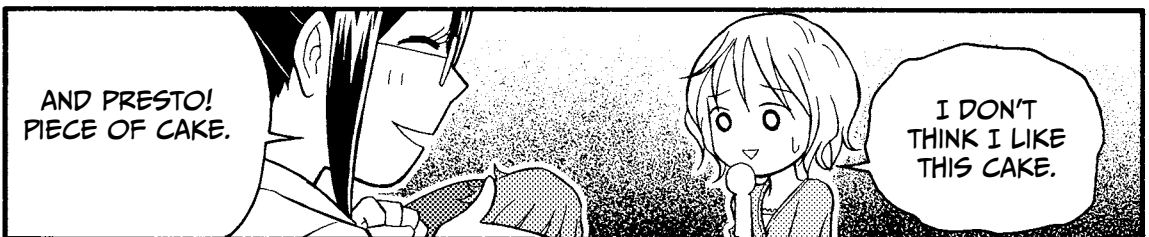
$$\frac{dS_e}{db} = 2(-1)\{469 - (a_1 \times 10 + a_2 \times 80 + b)\} + 2(-1)\{366 - (a_1 \times 8 + a_2 \times 0 + b)\} + \dots + 2(-1)\{364 - (a_1 \times 9 + a_2 \times 180 + b)\} = 0$$



COME ON!
SHARPEN YOUR
PENCILS AND GET
READY!

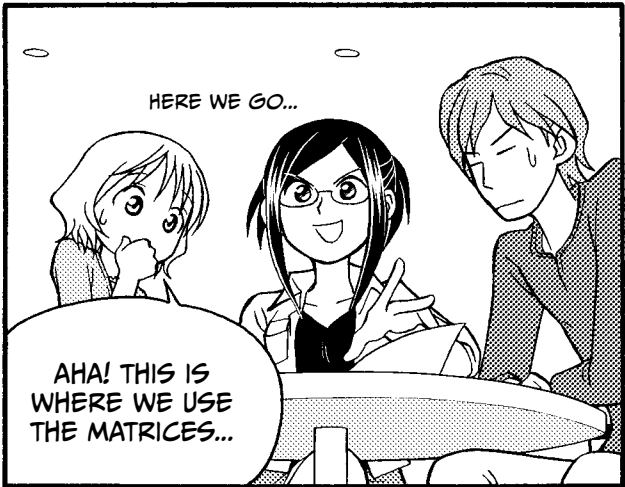

HERE WE GO...

AHA! THIS IS
WHERE WE USE
THE MATRICES...

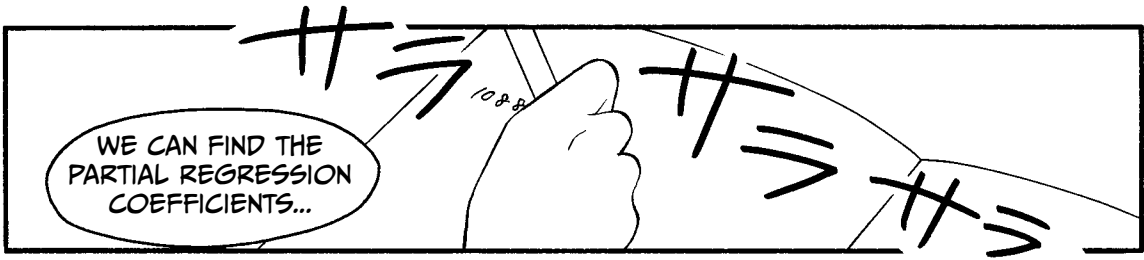

WE CAN FIND THE
PARTIAL REGRESSION
COEFFICIENTS...

$$\begin{pmatrix} 10 & 8 & 8 & 5 & 7 & 8 & 7 & 9 & 6 & 9 \\ 80 & 0 & 200 & 200 & 300 & 230 & 40 & 0 & 330 & 180 \\ | & | & | & | & | & | & | & | & | & | \end{pmatrix}$$

$$\begin{pmatrix} 10 & 80 & | \\ 8 & 0 & | \\ 8 & 200 & | \\ 5 & 200 & | \\ 7 & 300 & | \\ 8 & 230 & | \\ 7 & 40 & | \\ 9 & 0 & | \\ 6 & 330 & | \\ 9 & 180 & | \end{pmatrix}^{-1}$$

$$\begin{pmatrix} 10 & 8 & 8 & 5 & 7 & 8 & 7 & 9 & 6 & 9 \\ 80 & 0 & 200 & 200 & 300 & 230 & 40 & 0 & 330 & 180 \\ | & | & | & | & | & | & | & | & | & | \end{pmatrix}$$

$$\begin{pmatrix} 489 \\ 366 \\ 371 \\ 208 \\ 246 \\ 297 \\ 363 \\ 436 \\ 198 \\ 364 \end{pmatrix}$$

THIS BIG THING IS
EQUAL TO THE PARTIAL
REGRESSION COEFFICIENT!

...BY DOING THIS
CALCULATION!

WHAT THE
HECK IS
THIS?!

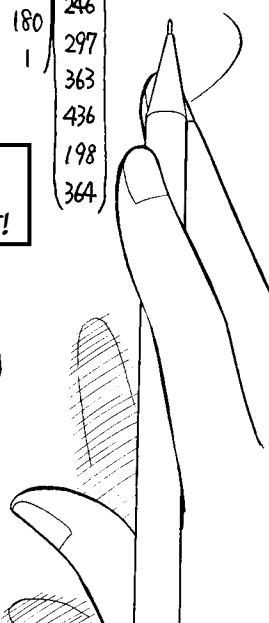

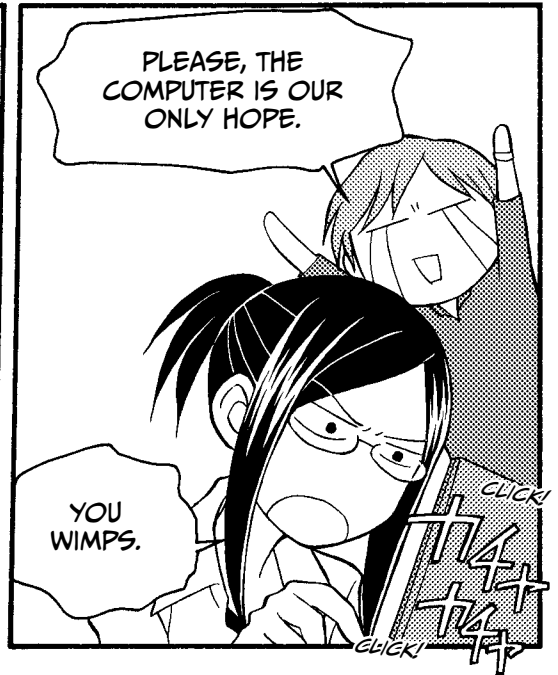
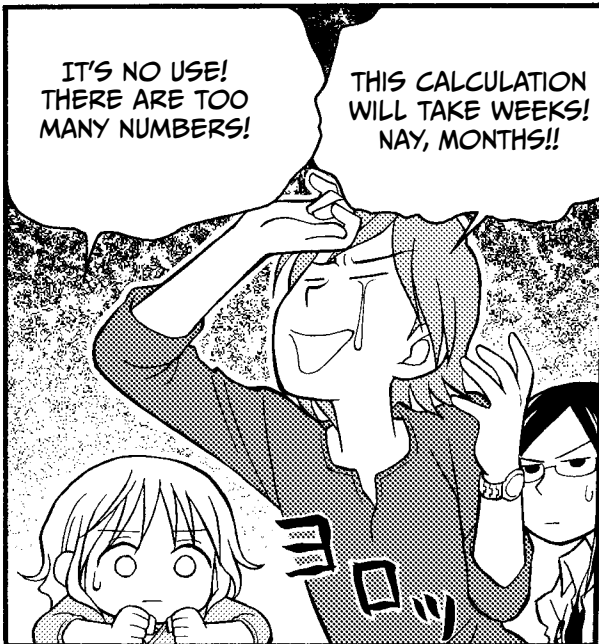
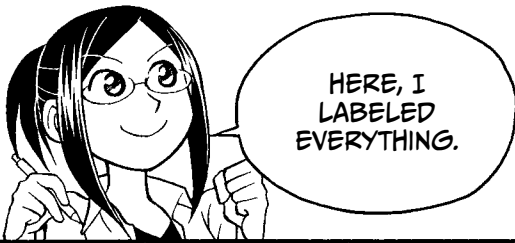
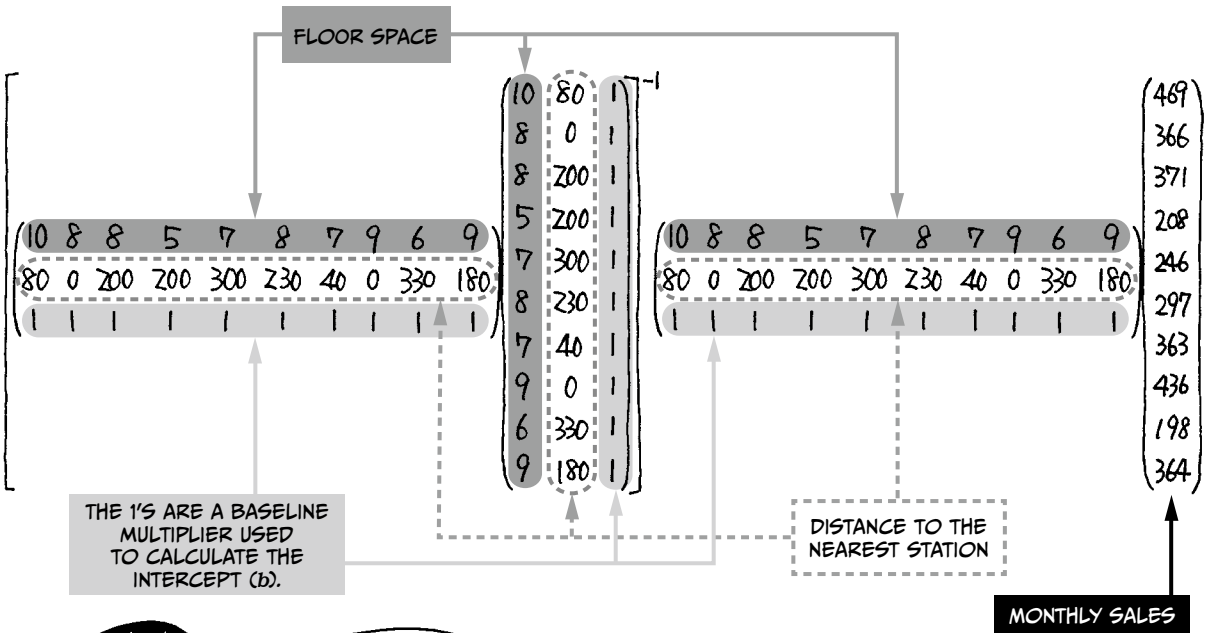

<p>FINE! I'LL DO IT FOR YOU...*</p>	Predictor variable	Partial regression coefficients
	Floor space of the shop (tsubo)	$\alpha_1 = 41.5$
	Distance to the nearest station (meters)	$\alpha_2 = -0.3$
	Intercept	$b = 65.3$

HOORAY!! 

* SEE PAGE 209 FOR THE FULL CALCULATION.

YOU ARE A GENIUS.

SAVE IT, LAZYPONES.

SO HERE'S THE EQUATION.

$$y = 41.5x_1 - 0.3x_2 + 65.3$$

↑ MONTHLY SALES ↑ FLOOR SPACE ↑ DISTANCE TO THE NEAREST STATION

YOU SHOULD WRITE THIS DOWN.

FINALLY! PAY DIRT.

THERE'S ONE MORE THING...

...THAT WILL HELP YOU UNDERSTAND THE MULTIPLE REGRESSION EQUATION AND MULTIPLE REGRESSION ANALYSIS.

WHAT IS IT? 

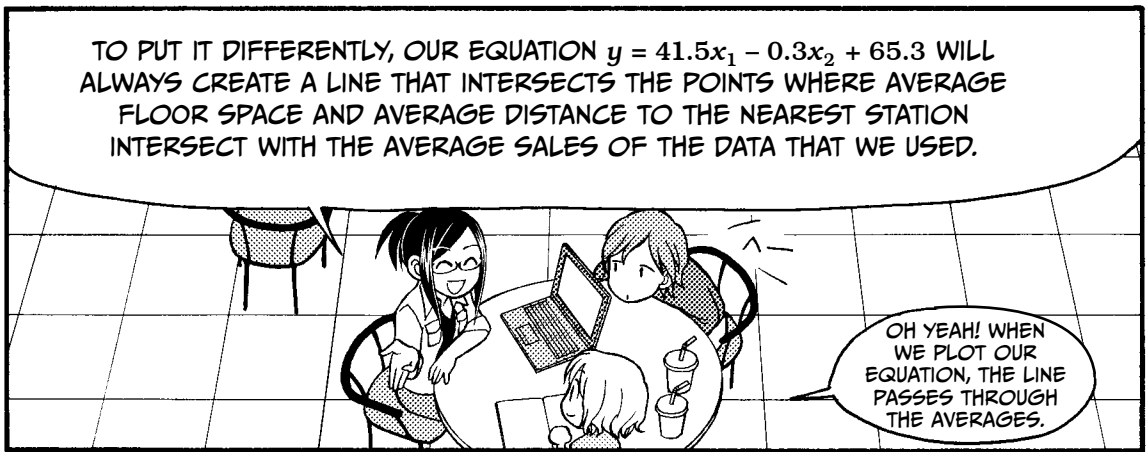
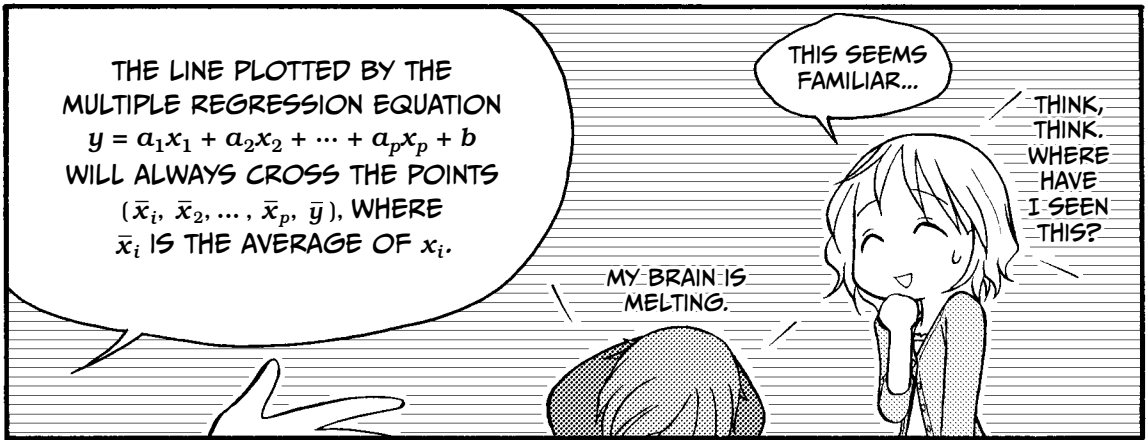

STEP 3: EXAMINE THE ACCURACY OF THE MULTIPLE REGRESSION EQUATION.

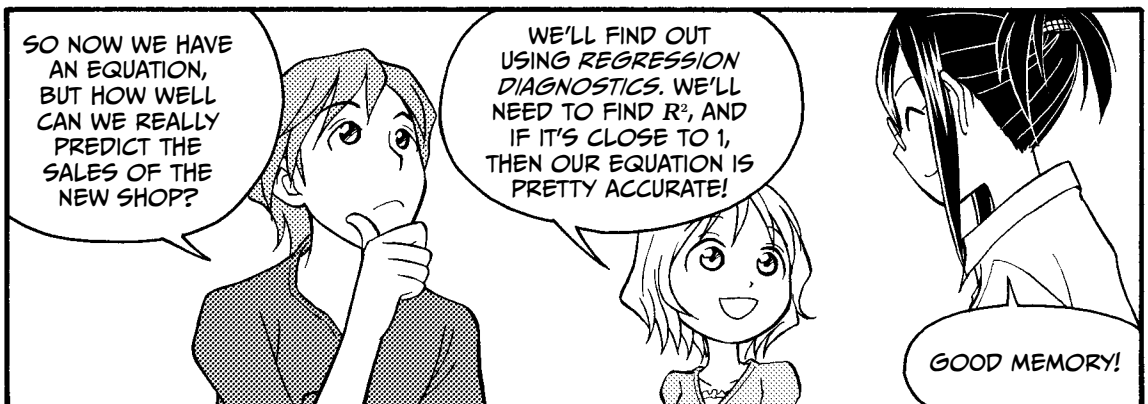

BEFORE WE FIND R^2 , WE NEED TO FIND PLAIN OLD R , WHICH IN THIS CASE IS CALLED THE MULTIPLE CORRELATION COEFFICIENT. REMEMBER: R IS A WAY OF COMPARING THE ACTUAL MEASURED VALUES (y) WITH OUR ESTIMATED VALUES (\hat{y}).*



Bakery	Actual value	Estimated value	$y - \bar{y}$	$\hat{y} - \bar{\hat{y}}$	$(y - \bar{y})^2$	$(\hat{y} - \bar{\hat{y}})^2$	$(y - \bar{y})(\hat{y} - \bar{\hat{y}})$	$(y - \hat{y})^2$
	y	$\hat{y} = 41x_1 - 0.3x_2 + 65.3$						
Yumenooka	469	453.2	137.2	121.4	18823.8	14735.1	16654.4	250.0
Terai	366	397.4	34.2	65.6	1169.6	4307.5	2244.6	988.0
Sone	371	329.3	39.2	-2.5	1536.6	6.5	-99.8	1742.6
Hashimoto	208	204.7	-123.8	-127.1	15326.4	16150.7	15733.2	10.8
Kikyuu	246	253.7	-85.8	-78.1	7361.6	6016.9	6705.0	58.6
Post Office	297	319.0	-34.8	-12.8	1211.0	163.1	444.4	485.3
Suidobashi	363	342.3	31.2	10.5	973.4	109.9	327.1	429.2
Rokujo	436	438.9	104.2	107.1	10857.6	11480.1	11164.5	8.7
Wakaba	198	201.9	-133.8	-129.9	17902.4	16870.5	17378.8	15.3
Misato	364	377.6	32.2	45.8	1036.8	2096.4	1474.3	184.6
Total	3318	3318	0	0	76199.6	72026.6	72026.6	4173.0
Average	331.8	331.8						

↓
 \bar{y}

↓
 $\bar{\hat{y}}$

↓
 S_{yy}

↓
 $S_{\hat{y}\hat{y}}$

↓
 $S_{y\hat{y}}$

↓
 S_e

WE DON'T NEED S_e YET, BUT WE WILL USE IT LATER.



$$R = \frac{\text{sum of } (y - \bar{y})(\hat{y} - \bar{\hat{y}})}{\sqrt{\text{sum of } (y - \bar{y})^2 \times \text{sum of } (\hat{y} - \bar{\hat{y}})^2}} = \frac{S_{y\hat{y}}}{\sqrt{S_{yy} \times S_{\hat{y}\hat{y}}}}$$

$$= \frac{72026.6}{\sqrt{76199.6 \times 72026.6}} = .9722$$

$$R^2 = (.9722)^2 = .9452$$

R^2 IS .9452.

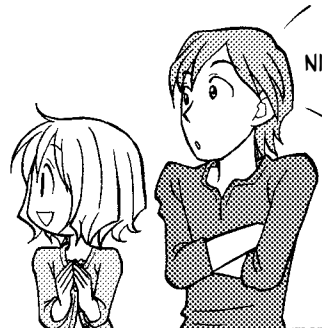

* AS IN CHAPTER 2, SOME OF THE FIGURES IN THIS CHAPTER ARE ROUNDED FOR READABILITY, BUT ALL CALCULATIONS ARE DONE USING THE FULL, UNROUNDED VALUES RESULTING FROM THE RAW DATA UNLESS OTHERWISE STATED.

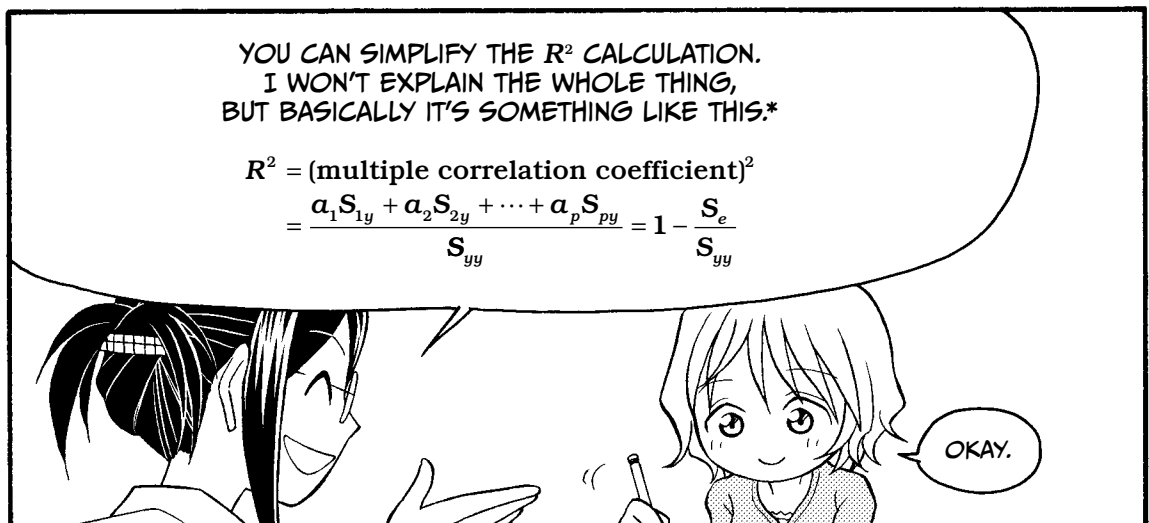
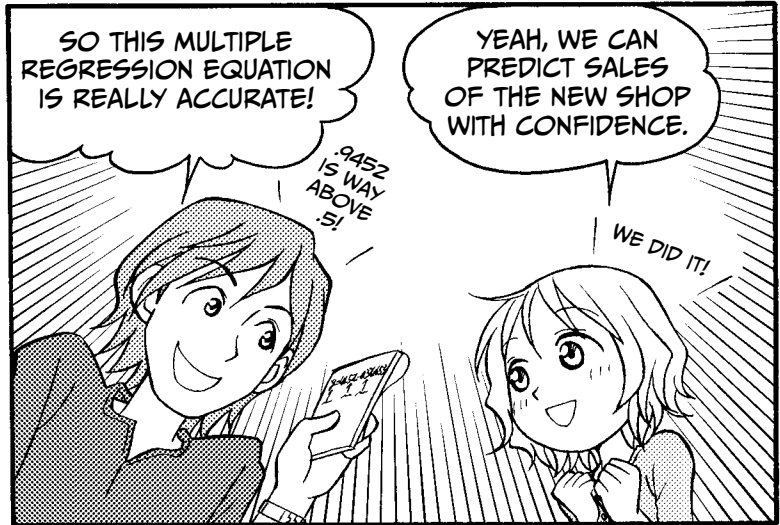
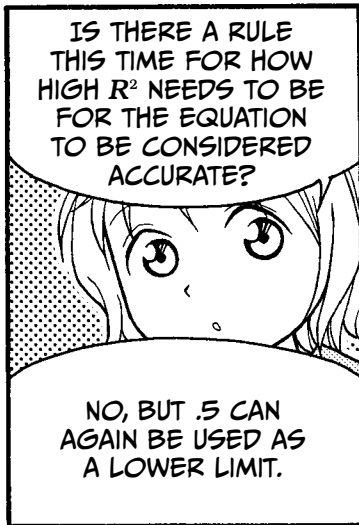
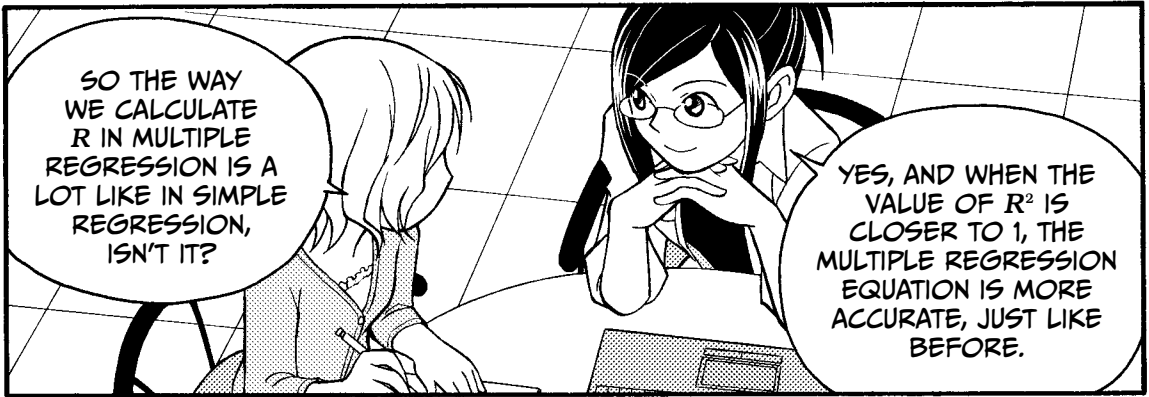

* REFER TO PAGE 144 FOR AN EXPLANATION OF S_{1y} , S_{2y} , ..., S_{py}

THE TROUBLE WITH R^2

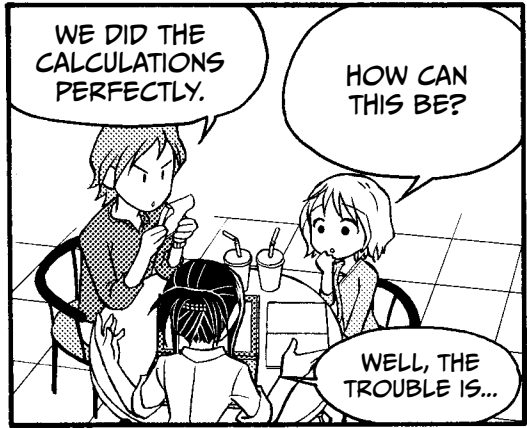
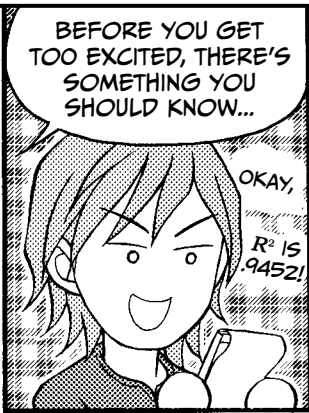

SUPPOSE WE ADD THE AGE OF THE SHOP MANAGER TO THE CURRENT DATA.

Bakery	Floor area of the shop (tsubo)	Distance to the nearest station (meters)	Shop manager's age (years)	Monthly sales (¥10,000)
Yumenooka Shop	10	80	42	469
Terai Station Shop	8	0	29	366
Sone Shop	8	200	33	371
Hashimoto Station Shop	5	200	41	208
Kikyou Town Shop	7	300	33	246
Post Office Shop	8	230	35	297
Suidobashi Shop	7	40	40	363
Rokujo Station Shop	9	0	46	436
Wakaba Riverside Shop	6	330	44	198
Misato Shop	9	180	34	364

AGE IS NOW THE THIRD PREDICTOR VARIABLE.

WHY WOULD AGE MATTER?





$$R^2 = .9495$$



$$R^2 = .9452$$

...IT'S .9495!

AS YOU CAN SEE, IT'S LARGER.

BUT WHEN WE PLOT AGE VERSUS MONTHLY SALES, THERE IS NO PATTERN, SO...

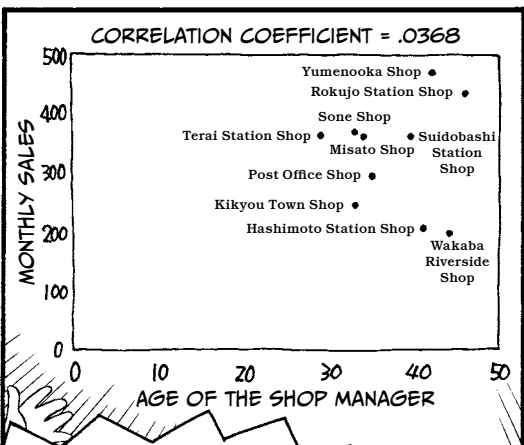

YET DESPITE THAT, THE VALUE OF R^2 INCREASED.

SO WHAT WAS THE POINT OF ALL THOSE CALCULATIONS?

THE AGE OF THE SHOP MANAGER HAS NOTHING TO DO WITH MONTHLY SALES!

I KNEW IT!

NEVER FEAR.

THE ADJUSTED COEFFICIENT OF DETERMINATION, AKA ADJUSTED R^2 , WILL SAVE US!

WHAT? ANOTHER R^2 ?

ADJUSTED R^2

THE VALUE OF ADJUSTED R^2 (\bar{R}^2) CAN BE OBTAINED BY USING THIS FORMULA.

$$\bar{R}^2 = 1 - \frac{\left(\frac{S_e}{\text{sample size} - \text{number of predictor variables} - 1} \right)}{\left(\frac{S_{yy}}{\text{sample size} - 1} \right)}$$

MIU, COULD YOU FIND THE VALUE OF ADJUSTED R^2 WITH AND WITHOUT THE AGE OF THE SHOP MANAGER?

UM, I THINK SO...

TOO MANY LAYERS!

IT'S WORSE THAN R^2 !

GO, MIU!

LET'S SEE...

WHEN THE PREDICTOR VARIABLES ARE ONLY FLOOR AREA AND DISTANCE...

... R^2 IS .9452.

SO ADJUSTED R^2 IS:

$$1 - \frac{\left(\frac{S_e}{\text{sample size} - \text{number of predictor variables} - 1} \right)}{\left(\frac{S_{yy}}{\text{sample size} - 1} \right)}$$

$$= 1 - \frac{\left(\frac{4173.0}{10 - 2 - 1} \right)}{\left(\frac{76199.6}{10 - 1} \right)} = \underline{\underline{.9296}}$$

I GOT IT!



HOW ABOUT WHEN WE ALSO INCLUDE THE SHOP MANAGER'S AGE?

WE'VE ALREADY GOT R^2 FOR THAT, RIGHT?

YES, IT'S .9495.

$R^2 = .9495$

FLOOR AREA OF THE SHOP

DISTANCE TO THE NEAREST STATION

AGE OF THE SHOP MANAGER

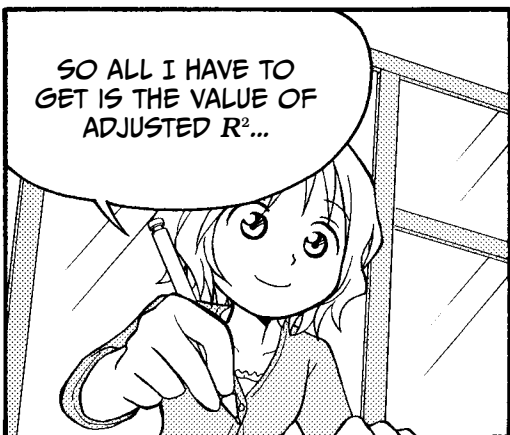

WHAT ARE S_{yy} AND S_e IN THIS CASE?

$\bar{R}^2 = 1 - \frac{S_e}{\text{sample size} - \text{number of predictor variables}}$

S_{yy} IS THE SAME AS BEFORE. IT'S 76199.6.

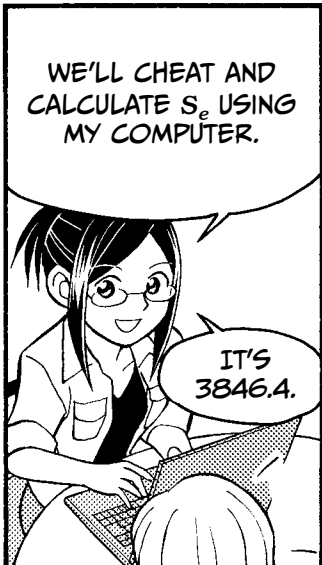

PREDICTOR VARIABLES:

- FLOOR AREA
- DISTANCE
- MANAGER'S AGE

$$1 - \frac{\left(\frac{S_e}{\text{sample size} - \text{number of predictor variables} - 1} \right)}{\left(\frac{S_{yy}}{\text{sample size} - 1} \right)}$$

$$= 1 - \frac{\left(\frac{3846.4}{10 - 3 - 1} \right)}{\left(\frac{76199.6}{10 - 1} \right)} = \underline{\underline{.9243}}$$

WAIT A MINUTE...



LOOK! THE VALUE OF ADJUSTED R^2 IS LARGER WHEN THE AGE OF THE SHOP MANAGER IS NOT INCLUDED.

	PREDICTOR VARIABLES	
	① FLOOR AREA AND DISTANCE	② FLOOR AREA, DISTANCE, AND AGE
R^2	.9452 <	.9495
\bar{R}^2	.9296 >	.9243

IT WORKED!



SEE? ADJUSTED R^2 TO THE RESCUE!

HEY, LOOK AT THIS.

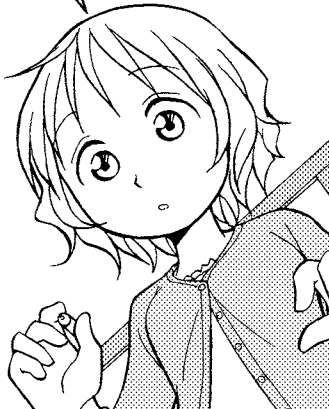

ADJUSTED R^2 IS SMALLER THAN R^2 IN BOTH CASES. IS IT ALWAYS SMALLER?

	① FLOOR AREA AND DISTANCE	② FLOOR AREA, DISTANCE, AND AGE
R^2	.9452 ✓	.9495 ✓
\bar{R}^2	.9296	.9243

GOOD EYE!
YES, IT IS ALWAYS SMALLER.



IS THAT GOOD?

IT MEANS THAT ADJUSTED R^2 IS A HARSHER JUDGE OF ACCURACY, SO WHEN WE USE IT, WE CAN BE MORE CONFIDENT IN OUR MULTIPLE REGRESSION EQUATION.

ADJUSTED R^2 IS AWESOME.

HYPOTHESIS TESTING WITH MULTIPLE REGRESSION

NOW...

\bar{R}^2

SINCE WE'RE HAPPY WITH ADJUSTED R^2 , WE'LL TEST OUR ASSUMPTIONS ABOUT THE POPULATION.

WE'LL DO HYPOTHESIS AND REGRESSION COEFFICIENT TESTS, RIGHT?

YES, BUT IN MULTIPLE REGRESSION ANALYSIS, WE HAVE PARTIAL REGRESSION COEFFICIENTS, INSTEAD.

DO YOU REMEMBER HOW WE DID THE HYPOTHESIS TESTING BEFORE?

I THINK SO. WE TESTED WHETHER THE POPULATION MATCHED THE EQUATION AND THEN CHECKED THAT A DIDN'T EQUAL ZERO.

RIGHT! IT'S BASICALLY THE SAME WITH MULTIPLE REGRESSION.

~ ALTERNATIVE HYPOTHESIS ~

IF THE FLOOR AREA OF THE SHOP IS x_1 TSUBO AND THE DISTANCE TO THE NEAREST STATION IS x_2 METERS, THE MONTHLY SALES FOLLOW A NORMAL DISTRIBUTION WITH MEAN $A_1x_1 + A_2x_2 + B$ AND STANDARD DEVIATION σ .

NOW, WE HAVE MORE THAN ONE x AND MORE THAN ONE A . AT LEAST ONE OF THESE A 'S MUST NOT EQUAL ZERO.

I SEE!

STEP 4: CONDUCT THE ANALYSIS OF VARIANCE (ANOVA) TEST.

HERE ARE OUR ASSUMPTIONS ABOUT THE PARTIAL REGRESSION COEFFICIENTS. a_1 , a_2 , AND b ARE COEFFICIENTS OF THE ENTIRE POPULATION.

IF THE REGRESSION EQUATION OBTAINED IS

$$y = a_1x_1 + a_2x_2 + b$$

- A_1 IS APPROXIMATELY a_1 .
- A_2 IS APPROXIMATELY a_2 .
- B IS APPROXIMATELY b .

$$\sigma = \sqrt{\frac{S_e}{\text{sample size} - \text{number of predictor variables} - 1}}$$

THE EQUATION SHOULD REFLECT THE POPULATION.

COULD YOU APPLY THIS TO KAZAMI BAKERY'S DATA?

SURE.

THE MULTIPLE REGRESSION EQUATION IS $y = 41.5x_1 - 0.3x_2 + 65.3$, SO...

THESE ARE OUR ASSUMPTIONS.

- A_1 IS APPROXIMATELY 41.5.
- A_2 IS APPROXIMATELY -0.3.
- B IS APPROXIMATELY 65.3.
- $\sigma = \sqrt{\frac{4173.0}{10-2-1}} = 24.4$.

WONDERFUL!

NOW WE NEED TO TEST OUR MODEL USING AN F-TEST.

THERE ARE TWO TYPES.

ONE TESTS ALL THE PARTIAL REGRESSION COEFFICIENTS TOGETHER.

NULL HYPOTHESIS	$A_1 = 0$ AND $A_2 = 0$
ALTERNATIVE HYPOTHESIS	NOT $A_1 = A_2 = 0$

IN OTHER WORDS, ONE OF THE FOLLOWING IS TRUE:

- $A_1 \neq 0$ AND $A_2 \neq 0$
- $A_1 \neq 0$ AND $A_2 = 0$
- $A_1 = 0$ AND $A_2 \neq 0$

THE OTHER TESTS THE INDIVIDUAL PARTIAL REGRESSION COEFFICIENTS SEPARATELY.

NULL HYPOTHESIS	$A_i = 0$
ALTERNATIVE HYPOTHESIS	$A_i \neq 0$

SO, WE HAVE TO REPEAT THIS TEST FOR EACH OF THE PARTIAL REGRESSION COEFFICIENTS?

YES.

LET'S SET THE SIGNIFICANCE LEVEL TO .05. ARE YOU READY TO TRY DOING THESE TESTS?

YES, LET'S!

FIRST, WE'LL TEST ALL THE PARTIAL REGRESSION COEFFICIENTS TOGETHER.



THE STEPS OF ANOVA

Step 1	Define the population.	The population is all Kazami Bakery shops.
Step 2	Set up a null hypothesis and an alternative hypothesis.	Null hypothesis is $A_1 = 0$ and $A_2 = 0$. Alternative hypothesis is that A_1 or A_2 or both $\neq 0$.
Step 3	Select which hypothesis test to conduct.	We'll use an F -test.
Step 4	Choose the significance level.	We'll use a significance level of .05.
Step 5	Calculate the test statistic from the sample data.	The test statistic is: $\frac{S_{yy} - S_e}{\text{number of predictor variables}} \div \frac{S_e}{\text{sample size} - \text{number of predictor variables} - 1} =$ $\frac{76199.6 - 4173.0}{2} \div \frac{4173.0}{10 - 2 - 1} = 60.4$ <p>The test statistic, 60.4, will follow an F distribution with first degree of freedom 2 (the number of predictor variables) and second degree of freedom 7 (sample size minus the number of predictor variables minus 1), if the null hypothesis is true.</p>
Step 6	Determine whether the p -value for the test statistic obtained in Step 5 is smaller than the significance level.	At significance level .05, with d_1 being 2 and d_2 being 7 ($10 - 2 - 1$), the critical value is 4.7374. Our test statistic is 60.4.
Step 7	Decide whether you can reject the null hypothesis.	Since our test statistic is greater than the critical value, we reject the null hypothesis.

NEXT, WE'LL TEST THE INDIVIDUAL PARTIAL REGRESSION COEFFICIENTS. I WILL DO THIS FOR A_1 AS AN EXAMPLE.



THE STEPS OF ANOVA

Step 1	Define the population.	The population is all Kazami Bakery shops.
Step 2	Set up a null hypothesis and an alternative hypothesis.	Null hypothesis is $A_1 = 0$. Alternative hypothesis is $A_1 \neq 0$.
Step 3	Select which hypothesis test to conduct.	We'll use an F -test.
Step 4	Choose the significance level.	We'll use a significance level of .05.
Step 5	Calculate the test statistic from the sample data.	The test statistic is: $\frac{\alpha_1^2}{S_{11}} \div \frac{S_e}{\text{sample size} - \text{number of predictor variables} - 1} =$ $\frac{41.5^2}{0.0657} \div \frac{4173.0}{10 - 2 - 1} = 44$ <p>The test statistic will follow an F distribution with first degree of freedom 1 and second degree of freedom 7 (sample size minus the number of predictor variables minus 1), if the null hypothesis is true. (The value of S_{11} will be explained on the next page.)</p>
Step 6	Determine whether the p -value for the test statistic obtained in Step 5 is smaller than the significance level.	At significance level .05, with d_1 being 1 and d_2 being 7, the critical value is 5.5914. Our test statistic is 44.
Step 7	Decide whether you can reject the null hypothesis.	Since our test statistic is greater than the critical value, we reject the null hypothesis.

REGARDLESS OF THE RESULT OF STEP 7, IF THE VALUE OF THE TEST STATISTIC

$$\frac{\alpha_1^2}{S_{11}} \div \frac{S_e}{\text{sample size} - \text{number of predictor variables} - 1}$$

IS 2 OR MORE, WE STILL CONSIDER THE PREDICTOR VARIABLE CORRESPONDING TO THAT PARTIAL REGRESSION COEFFICIENT TO BE USEFUL FOR PREDICTING THE OUTCOME VARIABLE.

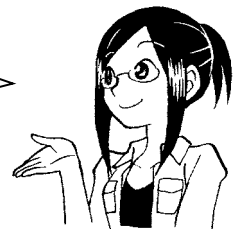

FINDING S_{11} AND S_{22}

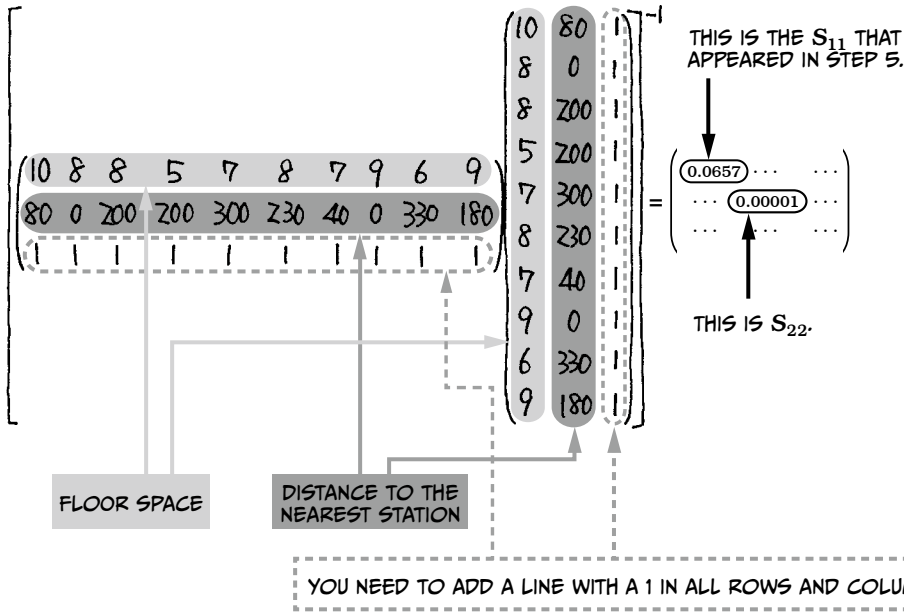

WE USE A MATRIX TO FIND S_{11} AND S_{22} . WE NEEDED S_{11} TO CALCULATE THE TEST STATISTIC ON THE PREVIOUS PAGE, AND WE USE S_{22} TO TEST OUR SECOND COEFFICIENT INDEPENDENTLY, IN THE SAME WAY.*



SO A_1 DOESN'T EQUAL ZERO! WE CAN REJECT THE NULL HYPOTHESIS.

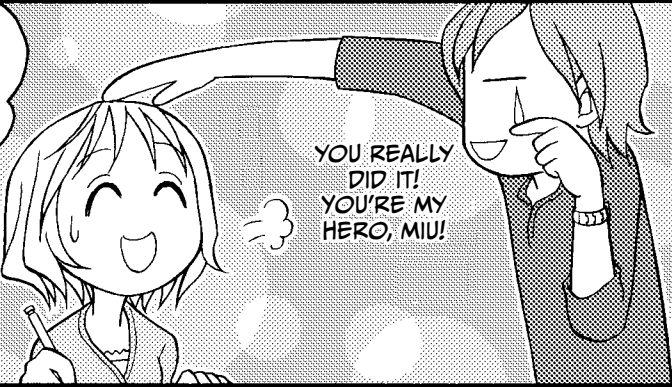

YOU REALLY DID IT! YOU'RE MY HERO, MIU!

* SOME PEOPLE USE THE t DISTRIBUTION INSTEAD OF THE F DISTRIBUTION WHEN EXPLAINING THE "TEST OF PARTIAL REGRESSION COEFFICIENTS." YOUR FINAL RESULT WILL BE THE SAME NO MATTER WHICH METHOD YOU CHOOSE.

STEP 5: CALCULATE CONFIDENCE INTERVALS FOR THE POPULATION.

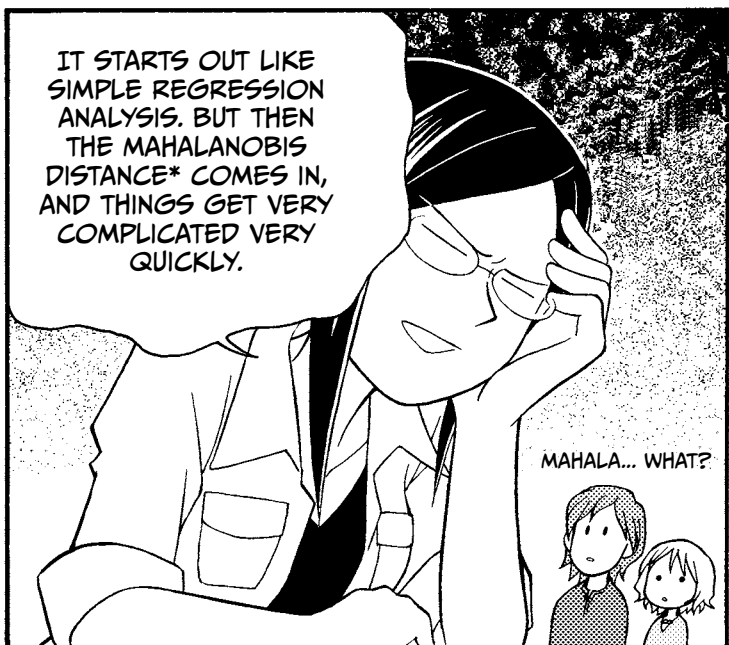
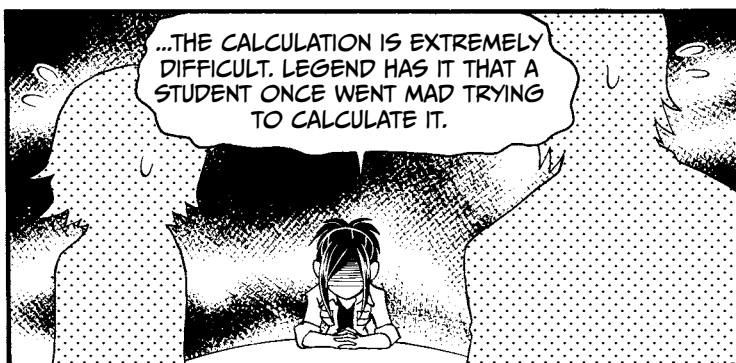
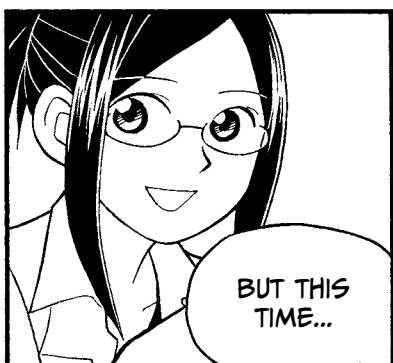
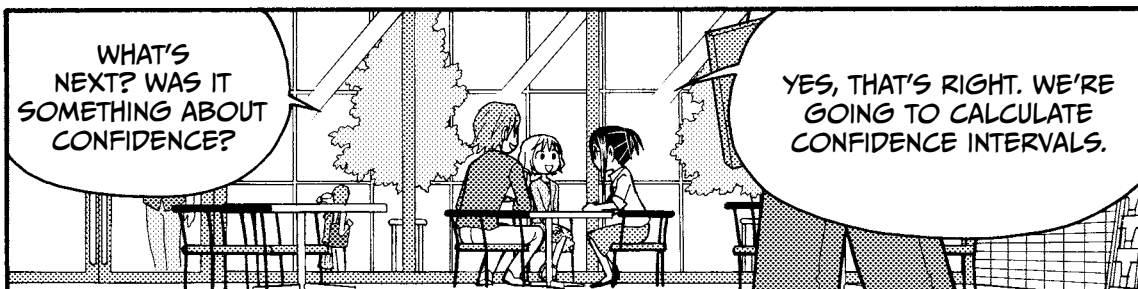

* THE MATHEMATICIAN P.C. MAHALANOBIS INVENTED A WAY TO USE MULTIVARIATE DISTANCES TO COMPARE POPULATIONS.

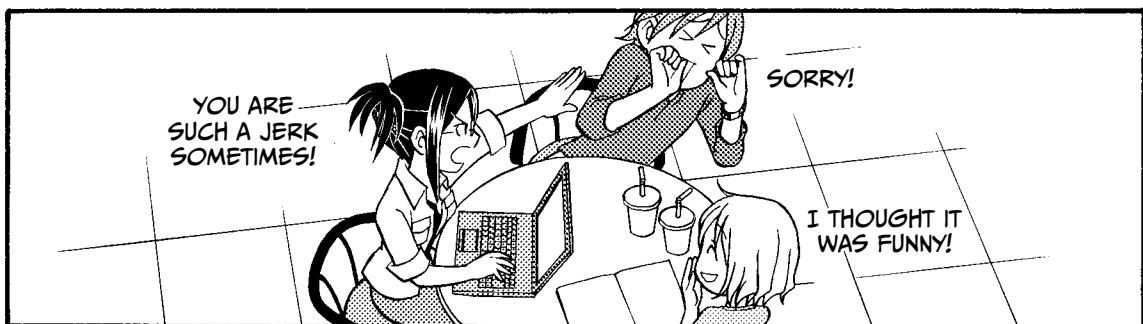
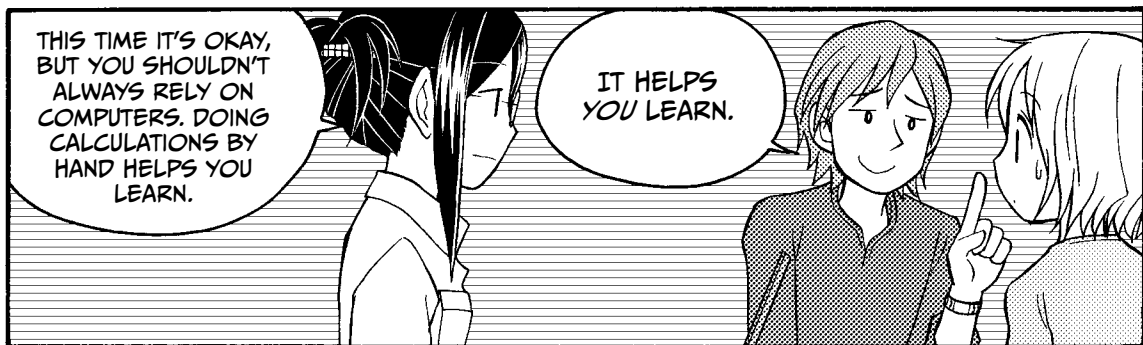
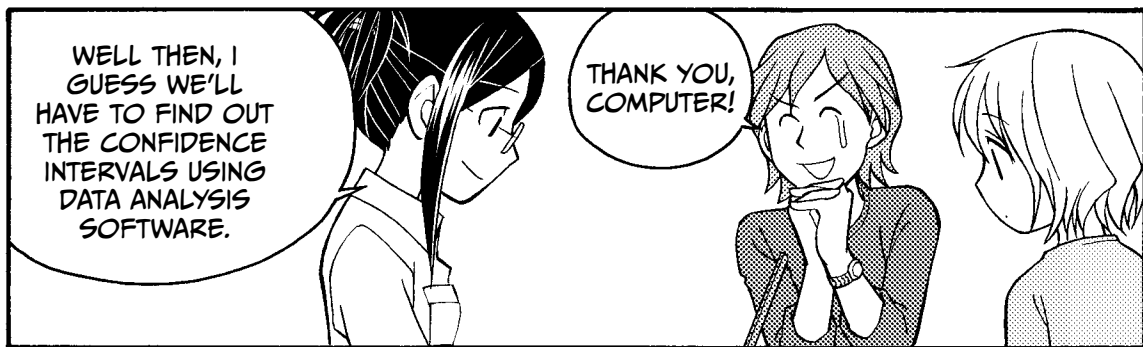
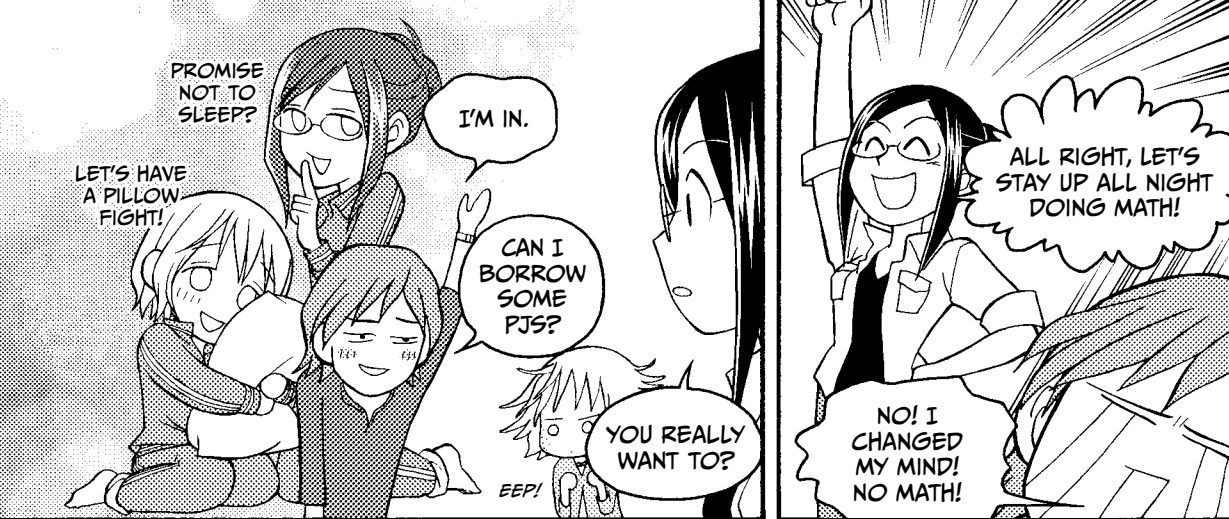

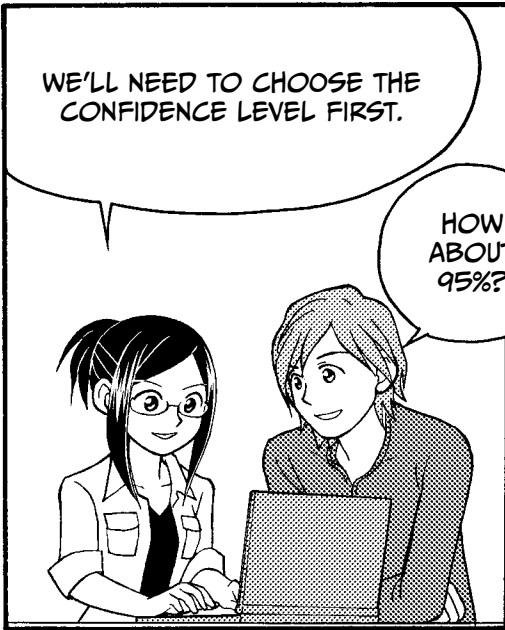

HOW ABOUT 95%?

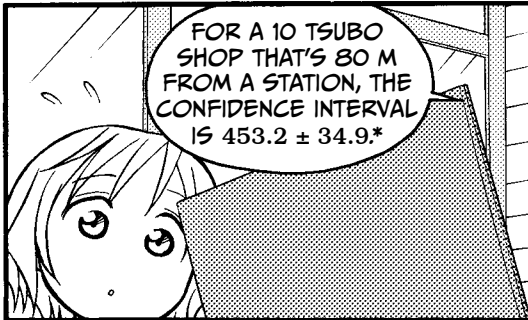
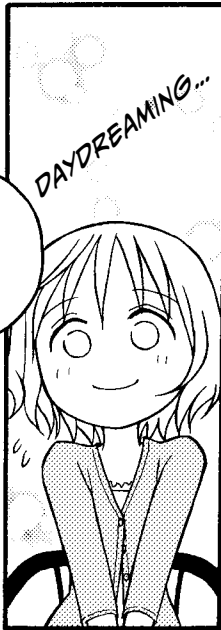

* THIS CALCULATION IS EXPLAINED IN MORE DETAIL ON PAGE 146.

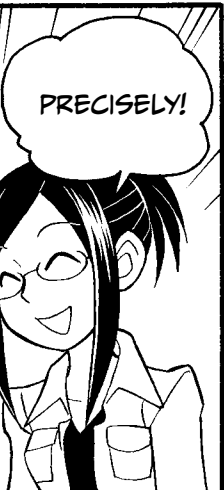
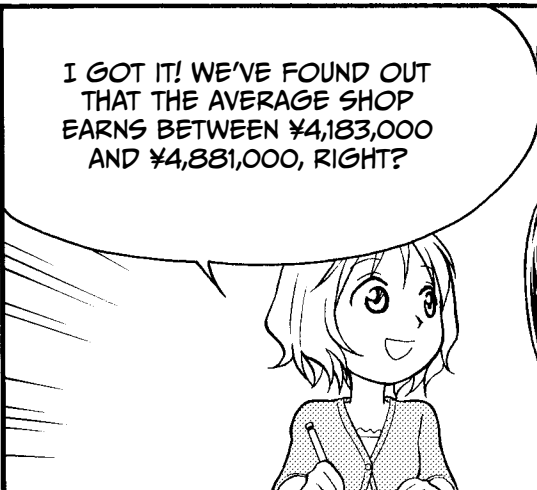
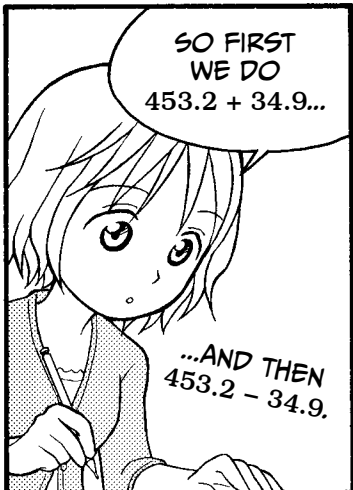

STEP 6: MAKE A PREDICTION!

HERE IS THE DATA FOR THE NEW SHOP WE'RE PLANNING TO OPEN.

	Floor space of the shop (tsubo)	Distance to the nearest station (meters)
Isebashi Shop	10	110

A SHOP IN ISEBASHI? THAT'S CLOSE TO MY HOUSE!

CAN YOU PREDICT THE SALES, MIU?

$$\begin{aligned}
 \hat{y} &= 41.5x_1 - 0.3x_2 + 65.3 \\
 &= 41.5 \times 10 - 0.3 \times 110 + 65.3 \\
 &= \underline{447.3^*}
 \end{aligned}$$

¥4,473,000 PER MONTH!

* THIS CALCULATION WAS MADE USING ROUNDED NUMBERS. IF YOU USE THE FULL, UNROUNDED NUMBERS, THE RESULT WILL BE 442.96.

YOU'RE A GENIUS, MIU! I SHOULD NAME THE SHOP AFTER YOU.

YOU SHOULD PROBABLY NAME IT AFTER RISA...

YEP!

BUT HOW COULD WE KNOW THE EXACT SALES OF A SHOP THAT HASN'T BEEN BUILT? SHOULD WE CALCULATE A PREDICTION INTERVAL?

ABSOLUTELY.

IN SIMPLE REGRESSION ANALYSIS, THE METHOD TO FIND BOTH THE CONFIDENCE AND PREDICTION INTERVALS WAS SIMILAR. IS THAT ALSO TRUE FOR MULTIPLE REGRESSION ANALYSIS?

YES, IT'S SIMILAR.

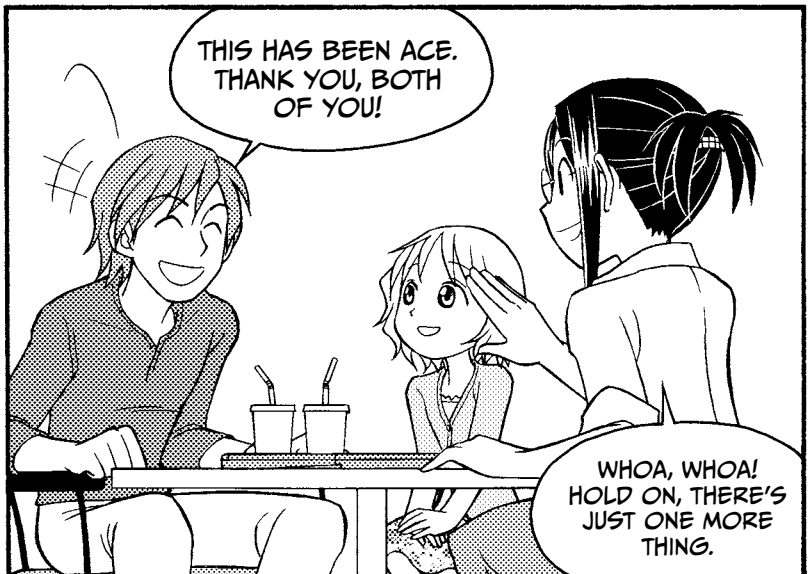
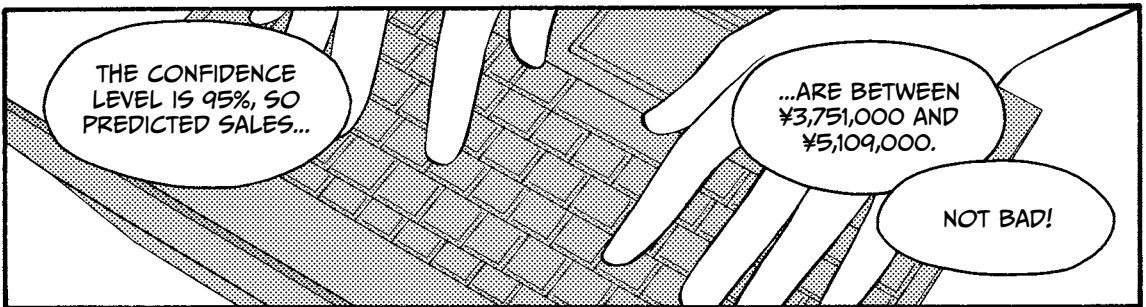
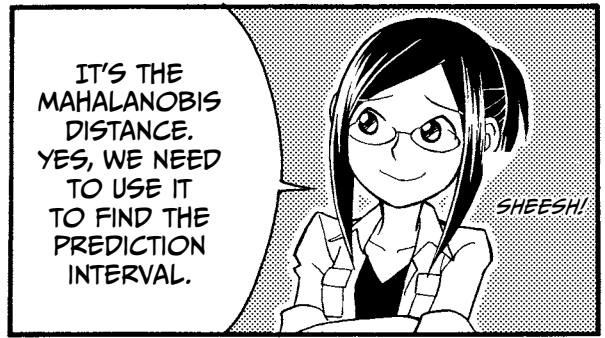

CHOOSING THE BEST COMBINATION OF PREDICTOR VARIABLES

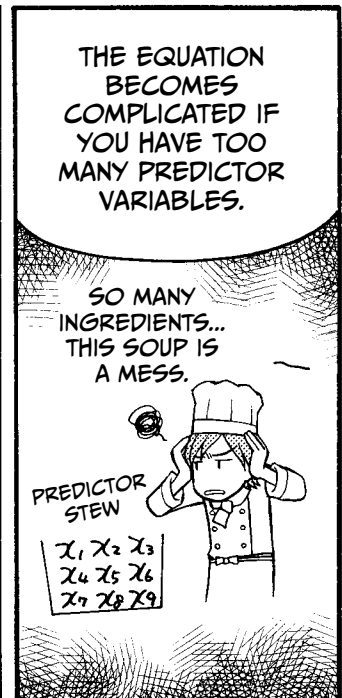
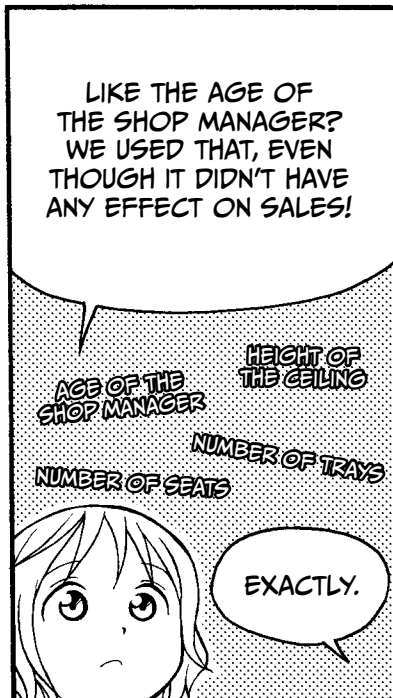
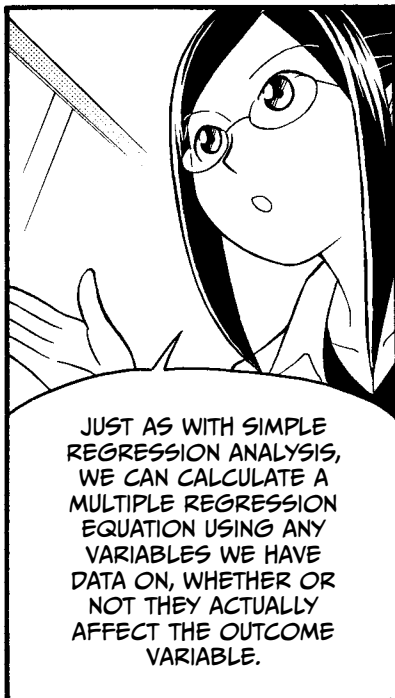
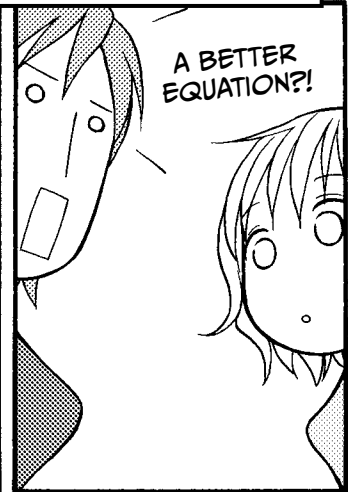
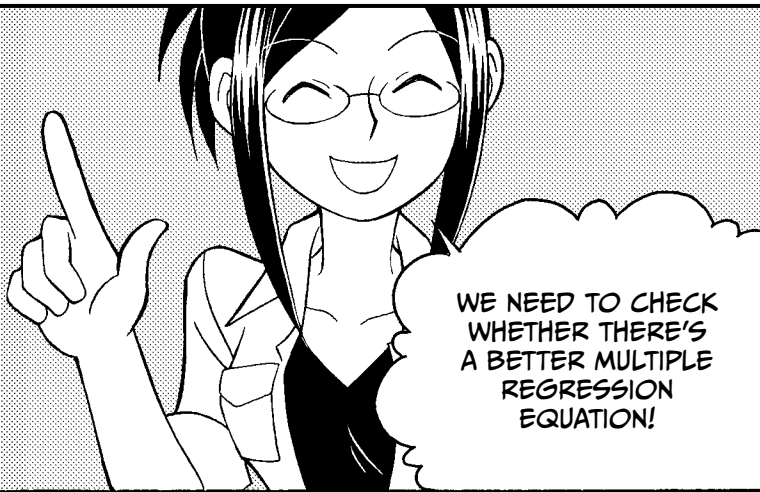

THE BEST MULTIPLE REGRESSION EQUATION BALANCES ACCURACY AND COMPLEXITY BY INCLUDING ONLY THE PREDICTOR VARIABLES NEEDED TO MAKE THE BEST PREDICTION.

DIFFICULT



$$y = a_1x_1 + a_2x_2 + a_3x_3 + a_4x_4 + a_5x_5 + a_6x_6 + \dots + b$$

EASY



$$y = a_1x_1 + a_2x_2 + b$$

ACCURATE



$$y = a_1x_1 + a_2x_2 + b$$

\bar{R}^2

>

NOT ACCURATE

$$y = a_1x_1 + a_3x_3 + b$$

\bar{R}^2



SHORT IS SWEET.



THERE ARE SEVERAL WAYS TO FIND THE EQUATION THAT GIVES YOU THE MOST BANG FOR YOUR BUCK.

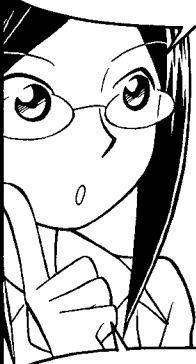

- FORWARD SELECTION
- BACKWARD ELIMINATION
- FORWARD-BACKWARD STEPWISE SELECTION
- ASK A DOMAIN EXPERT WHICH VARIABLES ARE THE MOST IMPORTANT

THESE ARE SOME COMMON WAYS.

THE METHOD WE'LL USE TODAY IS SIMPLER THAN ANY OF THOSE. IT'S CALLED BEST SUBSETS REGRESSION, OR SOMETIMES, THE ROUND-ROBIN METHOD.

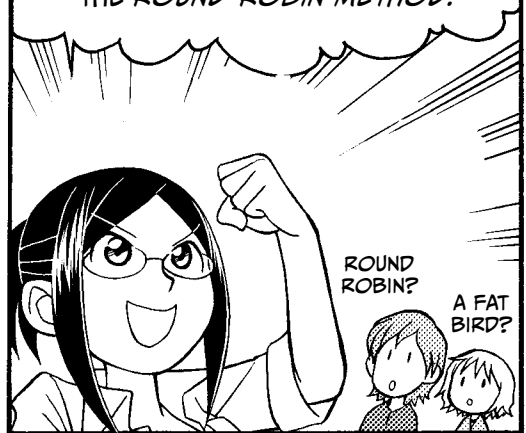

ROUND ROBIN?

A FAT BIRD?

WHAT THE HECK IS THAT?



x_1 x_2 x_3

I'LL SHOW YOU. SUPPOSE x_1 , x_2 , AND x_3 ARE POTENTIAL PREDICTOR VARIABLES.

FIRST, WE'D CALCULATE THE MULTIPLE REGRESSION EQUATION FOR EVERY COMBINATION OF PREDICTOR VARIABLES!

- x_1
- x_2
- x_3
- x_1 AND x_2
- x_2 AND x_3
- x_1 AND x_3
- x_1 AND x_2 AND x_3

HAHA. THIS SURE IS ROUND-ABOUT.



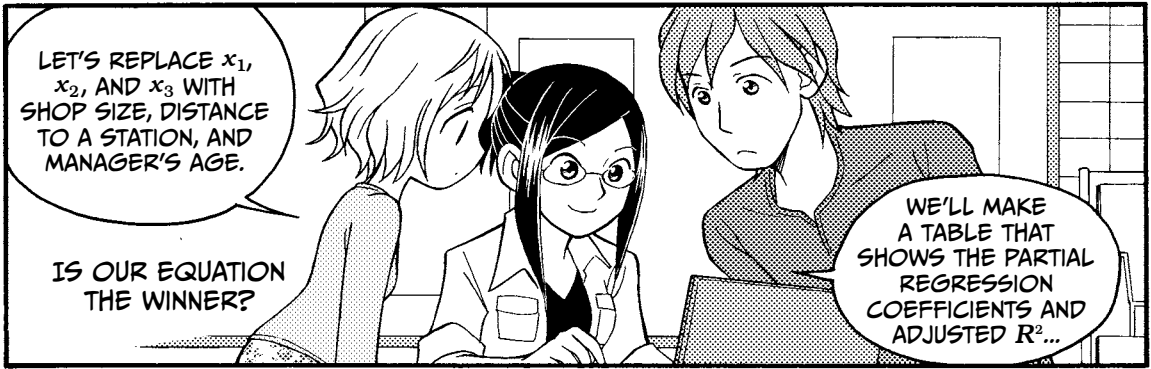

...LIKE THIS.

PRESTO!

Predictor variables	a_1	a_2	a_3	b	\bar{R}^2
1	54.9			-91.3	.07709
2		-0.6		424.8	.5508
3			0.6	309.1	.0000
1 and 2	41.5	-0.3		65.3	.9296
1 and 3	55.6		2.0	-170.1	.7563
2 and 3		-0.6	-0.4	438.9	.4873
1 and 2 and 3	42.2	-0.3	1.1	17.7	.9243

1 IS FLOOR AREA, 2 IS DISTANCE TO A STATION, AND 3 IS MANAGER'S AGE. WHEN 1 AND 2 ARE USED, ADJUSTED \bar{R}^2 IS HIGHEST.

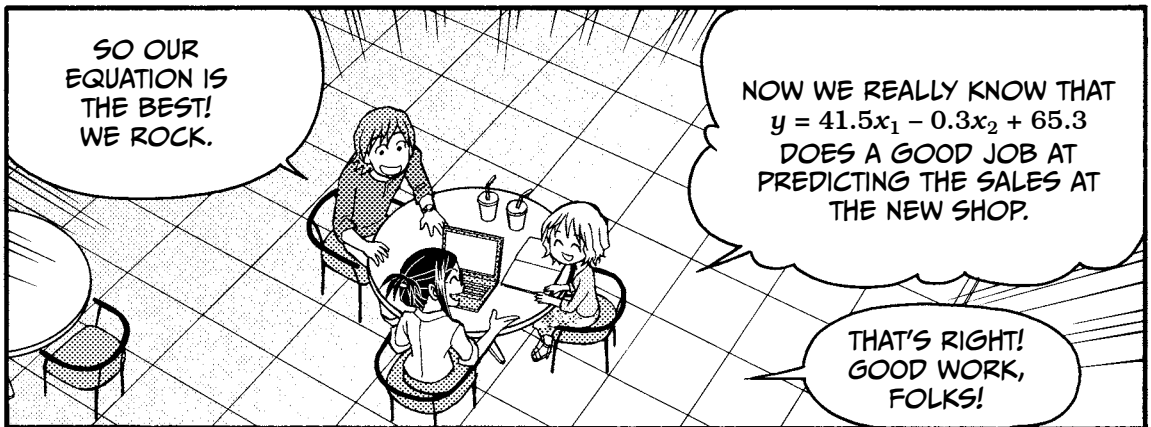

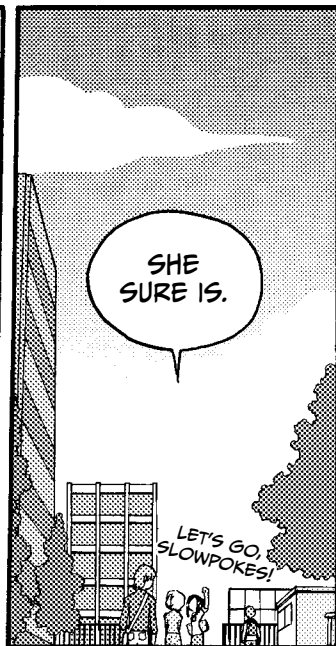
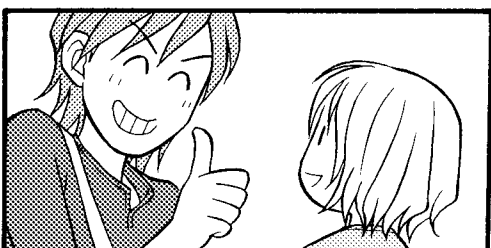
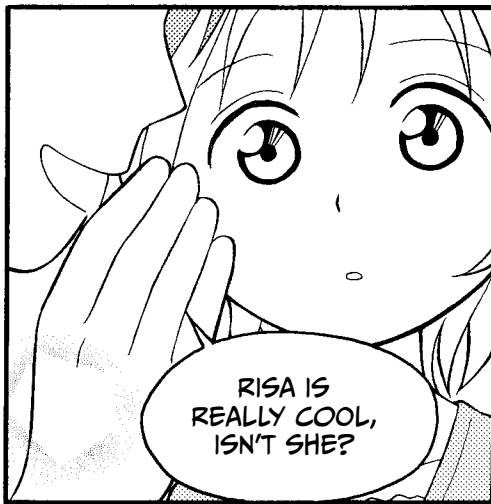
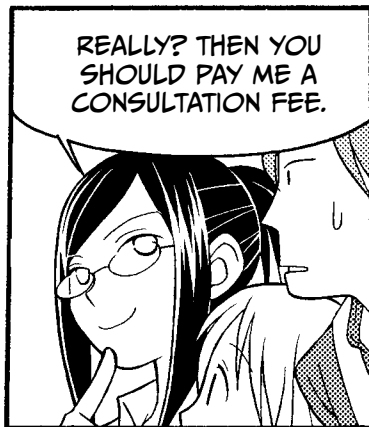
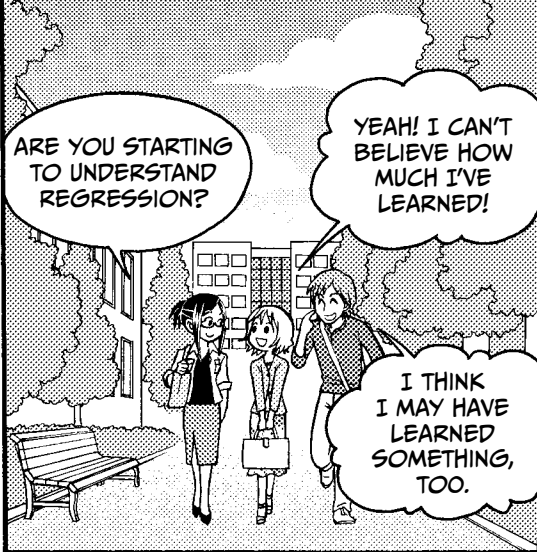
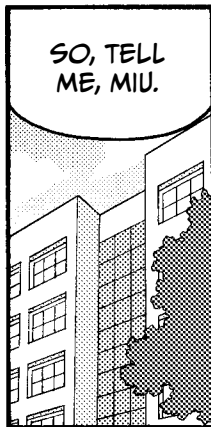

ASSESSING POPULATIONS WITH MULTIPLE REGRESSION ANALYSIS

Let's review the procedure of multiple regression analysis, shown on page 112.

1. Draw a scatter plot of each predictor variable and the outcome variable to see if they appear to be related.
2. Calculate the multiple regression equation.
3. Examine the accuracy of the multiple regression equation.
4. Conduct the analysis of variance (ANOVA) test.
5. Calculate confidence intervals for the population.
6. Make a prediction!

As in Chapter 2, we've talked about Steps 1 through 6 as if they were all mandatory. In reality, Steps 4 and 5 can be skipped for the analysis of some data sets.

Kazami Bakery currently has only 10 stores, and of those 10 stores, only one (Yumenooka Shop) has a floor area of 10 tsubo¹ and is 80 m to the nearest station. However, Risa calculated a confidence interval for the population of stores that were 10 tsubo and 80 m from a station. Why would she do that?

Well, it's possible that Kazami Bakery could open another 10-tsubo store that's also 80 m from a train station. If the chain keeps growing, there could be dozens of Kazami shops that fit that description. When Risa did that analysis, she was assuming that more 10-tsubo stores 80 m from a station might open someday.

The usefulness of this assumption is disputable. Yumenooka Shop has more sales than any other shop, so maybe the Kazami family will decide to open more stores just like that one. However, the bakery's next store, Isebashii Shop, will be 10 tsubo but 110 m from a station. In fact, it probably wasn't necessary to analyze such a specific population of stores. Risa could have skipped from calculating adjusted R^2 to making the prediction, but being a good friend, she wanted to show Miu all the steps.

1. Remember that 1 tsubo is about 36 square feet.

STANDARDIZED RESIDUALS

As in simple regression analysis, we calculate standardized residuals in multiple regression analysis when assessing how well the equation fits the actual sample data that's been collected.

Table 3-1 shows the residuals and standardized residuals for the Kazami Bakery data used in this chapter. An example calculation is shown for the Misato Shop.

TABLE 3-1: STANDARDIZED RESIDUALS OF THE KAZAMI BAKERY EXAMPLE

Bakery	Floor area of the shop	Distance to the nearest station	Monthly sales	Monthly sales	Residual	Standardized residual
	x_1	x_2	y	$\hat{y} = 41.5x_1 - 0.3x_2 + 65.3$	$y - \hat{y}$	
Yumenooka Shop	10	80	469	453.2	15.8	0.8
Terai Station Shop	8	0	366	397.4	-31.4	-1.6
Sone Shop	8	200	371	329.3	41.7	1.8
Hashimoto Station Shop	5	200	208	204.7	3.3	0.2
Kikyou Town Shop	7	300	246	253.7	-7.7	-0.4
Post Office Shop	8	230	297	319.0	-22.0	1.0
Suidobashi Station Shop	7	40	363	342.3	20.7	1.0
Rokujo Station Shop	9	0	436	438.9	-2.9	-0.1
Wakaba Riverside Shop	6	330	198	201.9	-3.9	-0.2
Misato Shop	9	180	364	377.6	-13.6	-0.6

If a residual is positive, the measurement is higher than predicted by our equation, and if the residual is negative, the measurement is lower than predicted; if it's 0, the measurement and our prediction are the same. The absolute value of the residual tells us how well the equation predicted what actually happened. The larger the absolute value, the greater the difference between the measurement and the prediction.

If the absolute value of the standardized residual is greater than 3, the data point can be considered an *outlier*. Outliers are measurements that don't follow the general trend. In this case, an outlier could be caused by a store closure, by road construction around a store, or by a big event held at one of the bakeries—anything that would significantly affect sales. When you detect an outlier, you should investigate the data point to see if it needs to be removed and the regression equation calculated again.

MAHALANOBIS DISTANCE

The *Mahalanobis distance* was introduced in 1936 by mathematician and scientist P.C. Mahalanobis, who also founded the Indian Statistical Institute. Mahalanobis distance is very useful in statistics because it considers an entire set of data, rather than looking at each measurement in isolation. It's a way of calculating distance that, unlike the more common Euclidean concept of distance, takes into account the correlation between measurements to determine the similarity of a sample to an established data set. Because these calculations reflect a more complex relationship, a linear equation will not suffice. Instead, we use matrices, which condense a complex array of information into a more manageable form that can then be used to calculate all of these distances at once.

On page 137, Risa used her computer to find the prediction interval using the Mahalanobis distance. Let's work through that calculation now and see how she arrived at a prediction interval of ¥3,751,000 and ¥5,109,000 at a confidence level of 95%.

STEP 1

Obtain the inverse matrix of

$$\begin{pmatrix} S_{11} & S_{12} & \cdots & S_{1p} \\ S_{21} & S_{22} & \cdots & S_{2p} \\ \vdots & \vdots & \ddots & \vdots \\ S_{p1} & S_{p2} & \cdots & S_{pp} \end{pmatrix}, \text{ which is } \begin{pmatrix} S_{11} & S_{12} & \cdots & S_{1p} \\ S_{21} & S_{22} & \cdots & S_{2p} \\ \vdots & \vdots & \ddots & \vdots \\ S_{p1} & S_{p2} & \cdots & S_{pp} \end{pmatrix}^{-1} = \begin{pmatrix} S^{11} & S^{12} & \cdots & S^{1p} \\ S^{21} & S^{22} & \cdots & S^{2p} \\ \vdots & \vdots & \ddots & \vdots \\ S^{p1} & S^{p2} & \cdots & S^{pp} \end{pmatrix}.$$

The first matrix is the covariance matrix as calculated on page 132. The diagonal of this matrix (S_{11} , S_{22} , and so on) is the variance within a certain variable.

STEP 3

Now we can calculate the confidence interval, as illustrated here:

This is the confidence interval.

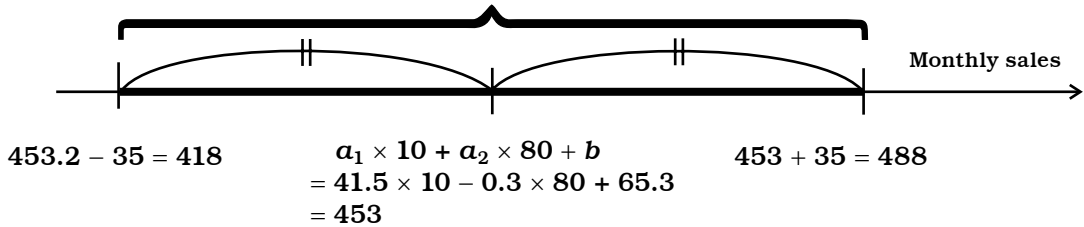

The minimum value of the confidence interval is the same distance from the mean as the maximum value of the interval. In other words, the confidence interval “straddles” the mean equally on each side. We calculate the distance from the mean as shown below (D^2 stands for Mahalanobis distance, and x represents the total number of predictors, not a value of some predictor):

$$\sqrt{F(1, \text{sample size} - x - 1; .05) \times \left(\frac{1}{\text{sample size}} + \frac{D^2}{\text{sample size} - 1} \right) \times \frac{S_e}{\text{sample size} - x - 1}}$$

$$= \sqrt{F(1, 10 - 2 - 1; .05) \times \left(\frac{1}{10} + \frac{2.4}{10 - 1} \right) \times \frac{4173.0}{10 - 2 - 1}}$$

$$= 35$$

As with simple regression analysis, when obtaining the prediction interval, we add 1 to the second term:

$$\sqrt{F(1, \text{sample size} - x - 1; .05) \times \left(1 + \frac{1}{\text{sample size}} + \frac{D^2}{\text{sample size} - 1} \right) \times \frac{S_e}{\text{sample size} - x - 1}}$$

If the confidence rate is 99%, just change the .05 to .01:

$$F(1, \text{sample size} - x - 1; .05) = F(1, 10 - 2 - 1; .05) = 5.6$$

$$F(1, \text{sample size} - x - 1; .01) = F(1, 10 - 2 - 1; .01) = 12.2$$

You can see that if you want to be more confident that the prediction interval will include the actual outcome, the interval needs to be larger.

USING CATEGORICAL DATA IN MULTIPLE REGRESSION ANALYSIS

Recall from Chapter 1 that categorical data is data that can't be measured with numbers. For example, the color of a store manager's eyes is categorical (and probably a terrible predictor variable for monthly sales). Although categorical variables can be *represented* by numbers (1 = blue, 2 = green), they are discrete—there's no such thing as “green and a half.” Also, one cannot say that 2 (green eyes) is greater than 1 (blue eyes). So far we've been using the numerical data (which can be meaningfully represented by continuous numerical values—110 m from the train station is further than 109.9 m) shown in Table 3-2, which also appears on page 113.

TABLE 3-2: KAZAMI BAKERY EXAMPLE DATA

Bakery	Floor space of the shop (tsubo)	Distance to the nearest station (meters)	Monthly sales (¥10,000)
Yumenooka Shop	10	80	469
Terai Station Shop	8	0	366
Sone Shop	8	200	371
Hashimoto Station Shop	5	200	208
Kikyuu Town Shop	7	300	246
Post Office Shop	8	230	297
Suidobashi Station Shop	7	40	363
Rokujo Station Shop	9	0	436
Wakaba Riverside Shop	6	330	198
Misato Shop	9	180	364

The predictor variable *floor area* is measured in tsubo, *distance to the nearest station* in meters, and *monthly sales* in yen. Clearly, these are all numerically measurable. In multiple regression analysis, the outcome variable must be a measurable, numerical variable, but the predictor variables can be

- all numerical variables,
- some numerical and some categorical variables, or
- all categorical variables.

Tables 3-3 and 3-4 both show valid data sets. In the first, categorical and numerical variables are both present, and in the second, all of the predictor variables are categorical.

In Table 3-4, we've converted numerical data (floor space and distance to a station) to categorical data by creating some general categories. Using this data, we calculate the multiple regression equation

$$y = 50.2x_1 - 110.1x_2 + 13.4x_3 + 75.1x_4 + 336.4$$

where y represents monthly sales, x_1 represents floor area, x_2 represents distance to the nearest station, x_3 represents samples every day, and x_4 represents samples on the weekend only.

MULTICOLLINEARITY

Multicollinearity occurs when two of the predictor variables are strongly correlated with each other. When this happens, it's hard to distinguish between the effects of these variables on the outcome variable, and this can have the following effects on your analysis:

- Less accurate estimate of the impact of a given variable on the outcome variable
- Unusually large standard errors of the regression coefficients
- Failure to reject the null hypothesis
- *Overfitting*, which means that the regression equation describes a relationship between the outcome variable and random error, rather than the predictor variable

The presence of multicollinearity can be assessed by using an index such as *tolerance* or the inverse of tolerance, known as the *variance inflation factor (VIF)*. Generally, a tolerance of less than 0.1 or a VIF greater than 10 is thought to indicate significant multicollinearity, but sometimes more conservative thresholds are used.

When you're just starting out with multiple regression analysis, you don't need to worry too much about this. Just keep in mind that multicollinearity can cause problems when it's severe. Therefore, when predictor variables are correlated to each other strongly, it may be better to remove one of the highly correlated variables and then reanalyze the data.

DETERMINING THE RELATIVE INFLUENCE OF PREDICTOR VARIABLES ON THE OUTCOME VARIABLE

Some people use multiple regression analysis to examine the relative influence of each predictor variable on the outcome variable. This is a fairly common and accepted use of multiple regression analysis, but it's not always a wise use.

The story below illustrates how one researcher used multiple regression analysis to assess the relative impact of various factors on the overall satisfaction of people who bought a certain type of candy.

Mr. Torikoshi is a product development researcher in a confectionery company. He recently developed a new soda-flavored candy, Magic Fizz, that fizzes when wet. The candy is selling astonishingly well. To find out what makes it so popular, the company gave free samples of the candy to students at the local university and asked them to rate the product using the following questionnaire.

MAGIC FIZZ QUESTIONNAIRE

Please let us know what you thought of Magic Fizz by answering the following questions. Circle the answer that best represents your opinion.

Flavor	1. Unsatisfactory 2. Satisfactory 3. Exceptional
Texture	1. Unsatisfactory 2. Satisfactory 3. Exceptional
Fizz sensation	1. Unsatisfactory 2. Satisfactory 3. Exceptional
Package design	1. Unsatisfactory 2. Satisfactory 3. Exceptional
Overall satisfaction	1. Unsatisfactory 2. Satisfactory 3. Exceptional

Twenty students returned the questionnaires, and the results are compiled in Table 3-5. Note that unlike in the Kazami Bakery example, the values of the outcome variable—overall satisfaction—are already known. In the bakery problem, the goal was to predict the outcome variable (profit) of a not-yet-existing store based on the trends shown by existing stores. In this case, the purpose of this analysis is to examine the relative effects of the different predictor variables in order to learn how each of the predictors (flavor, texture, sensation, design) affects the outcome (satisfaction).

TABLE 3-5: RESULTS OF MAGIC FIZZ QUESTIONNAIRE

Respondent	Flavor	Texture	Fizz sensation	Package design	Overall satisfaction
1	2	2	3	2	2
2	1	1	3	1	3
3	2	2	1	1	3
3	2	2	1	1	1
4	3	3	3	2	2
5	1	1	2	2	1
6	1	1	1	1	1
7	3	3	1	3	3
8	3	3	1	2	2
9	3	3	1	2	3
10	1	1	3	1	1
11	2	3	2	1	3
12	2	1	1	1	1
13	3	3	3	1	3
14	3	3	1	3	3
15	3	2	1	1	2
16	1	1	3	3	1
17	2	2	2	1	1
18	1	1	1	3	1
19	3	1	3	3	3
20	3	3	3	3	3

Each of the variables was normalized before the multiple regression equation was calculated. Normalization reduces the effect of error or scale, allowing a researcher to compare two variables more accurately. The resulting equation is

$$y = 0.41x_1 + 0.32x_2 + 0.26x_3 + 0.11x_4$$

where y represents overall satisfaction, x_1 represents flavor, x_2 represents texture, x_3 represents fizz sensation, and x_4 represents package design.

If you compare the partial regression coefficients for the four predictor variables, you can see that the coefficient for flavor is the largest. Based on that fact, Mr. Torikoshi concluded that the flavor has the strongest influence on overall satisfaction.

Mr. Torikoshi's reasoning does make sense. The outcome variable is equal to the sum of the predictor variables multiplied by their partial regression coefficients. If you multiply a predictor variable by a higher number, it should have a greater impact on the final tally, right? Well, sometimes—but it's not always so simple.

Let's take a closer look at Mr. Torikoshi's reasoning as depicted here:

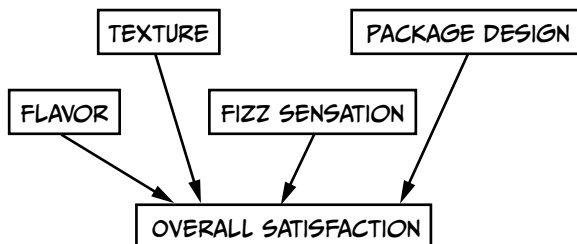

In other words, he is assuming that all the variables relate independently and directly to overall satisfaction. However, this is not necessarily true. Maybe in reality, the texture influences how satisfied people are with the flavor, like this:

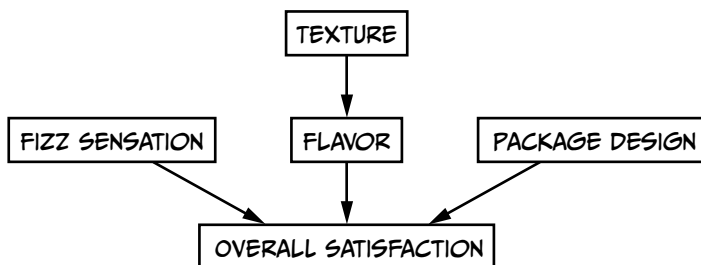

Structural equation modeling (SEM) is a better method for comparing the relative impact of various predictor variables on an outcome. This approach makes more flexible assumptions than linear regression does, and it can even be used to analyze data sets with multicollinearity. However, SEM is not a cure-all. It relies on the assumption that the data is relevant to answering the question asked.

SEM also assumes that the data is correctly modeled. It's worth noting that the questions in this survey ask each reviewer for a subjective interpretation. If Miu gave the candy two "satisfactory" and two "exceptional" marks, she might rate her overall satisfaction as either "satisfactory" or "exceptional." Which rating she picks might come down to what mood she is in that day!

Risa could rate the four primary categories the same as Miu, give a different overall satisfaction rating from Miu, and still be confident that she is giving an unbiased review. Because Miu and Risa had different thoughts on the final category, our data may not be correctly modeled. However, structural equation modeling can still yield useful results by telling us which variables have an impact on other variables rather than the final outcome.

4

LOGISTIC REGRESSION ANALYSIS

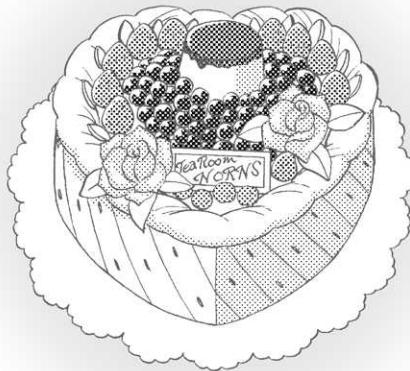

THE FINAL LESSON

...AND THE
CROISSANTS FOR
BREAKFAST.

I'VE GOT
DAD'S
COFFEE
BEANS...

WAS THERE
SOMETHING
ELSE...

HMMM...

OH YEAH!

DOGGY
SNACKS
FOR
REGGIE!

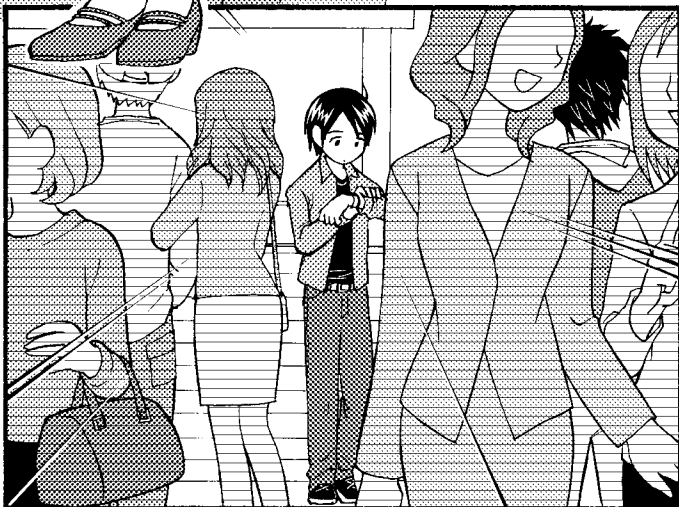
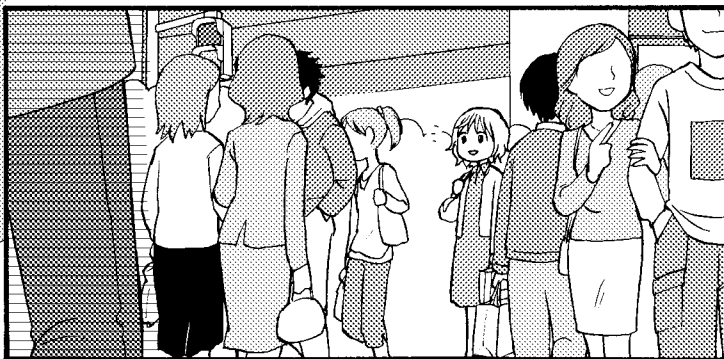

IT'S
HIM!





SHOULD I SAY HELLO?

I BET HE DOESN'T REMEMBER ME.



RISA WOULD TELL ME TO BE BOLD.



SHOULD I...?

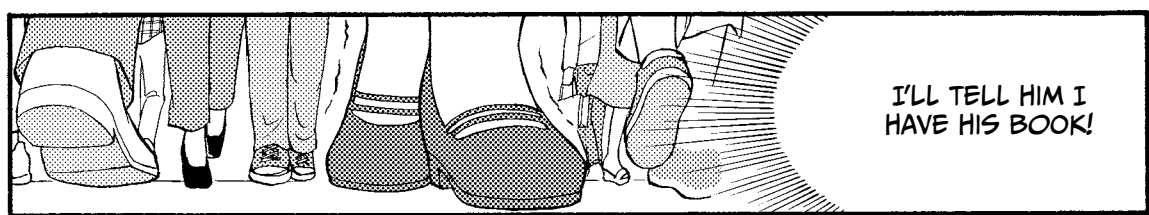

I'LL TELL HIM I HAVE HIS BOOK!



HE'LL WANT TO KNOW. HE NEEDS IT.



NO BIG DEAL.



SORRY I'M LATE!



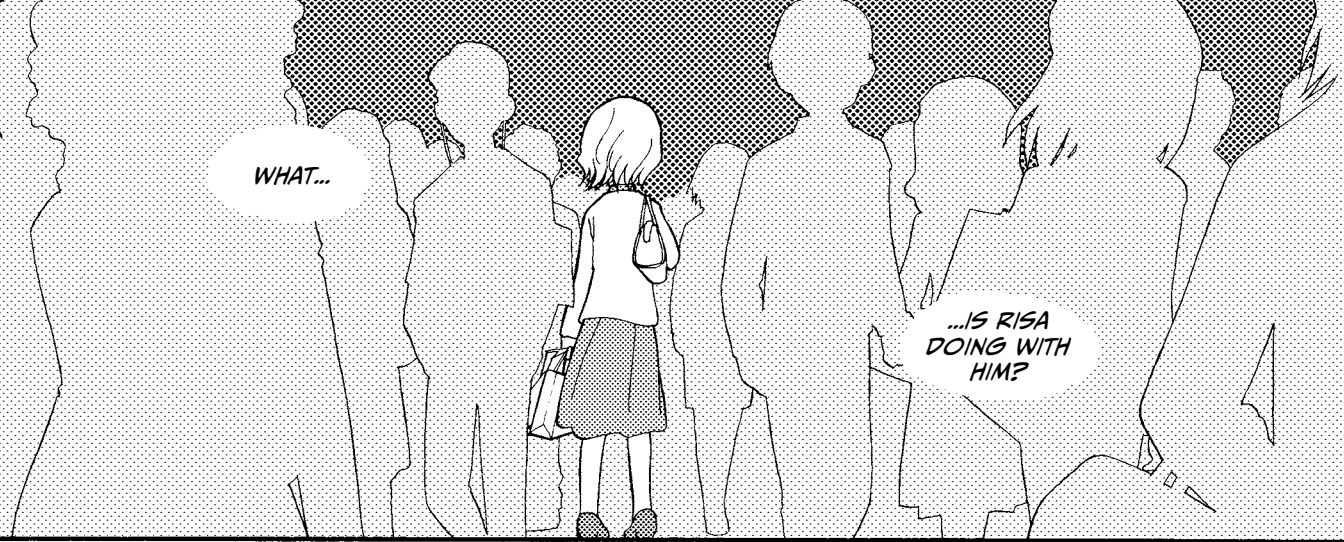

WHAT...

...IS RISA DOING WITH HIM?

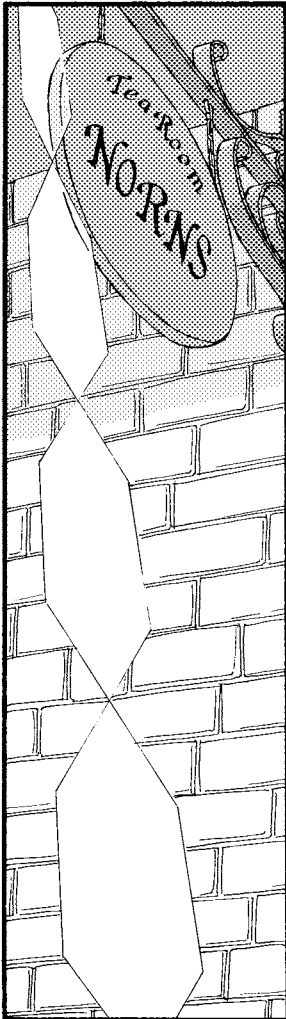

Tea Room
NO REAS

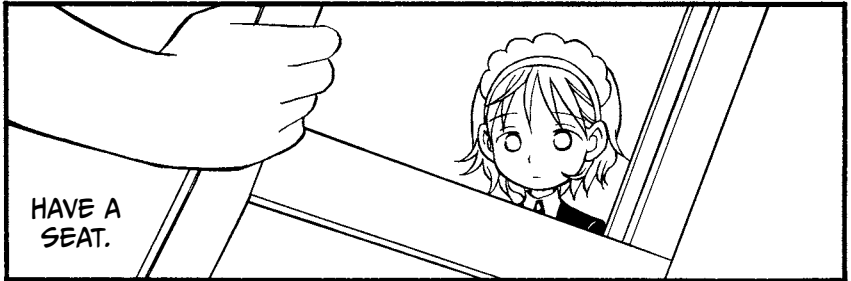

HAVE A SEAT.



MIU!

HUH?

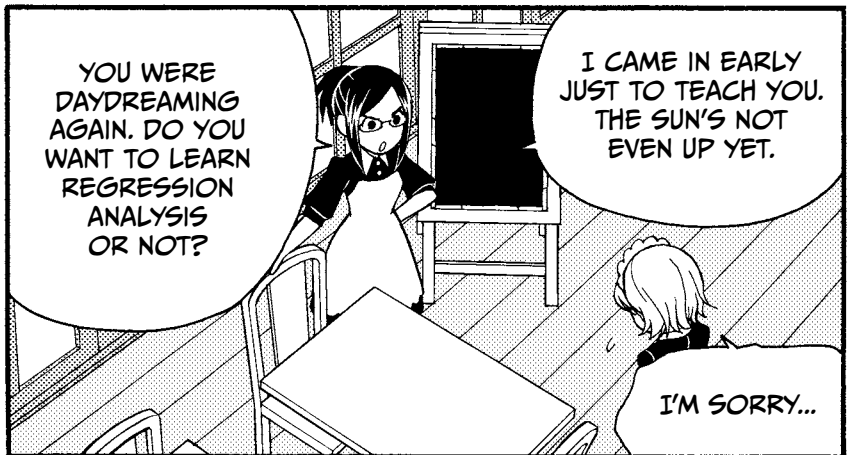

YOU WERE DAYDREAMING AGAIN. DO YOU WANT TO LEARN REGRESSION ANALYSIS OR NOT?

I CAME IN EARLY JUST TO TEACH YOU. THE SUN'S NOT EVEN UP YET.

I'M SORRY...

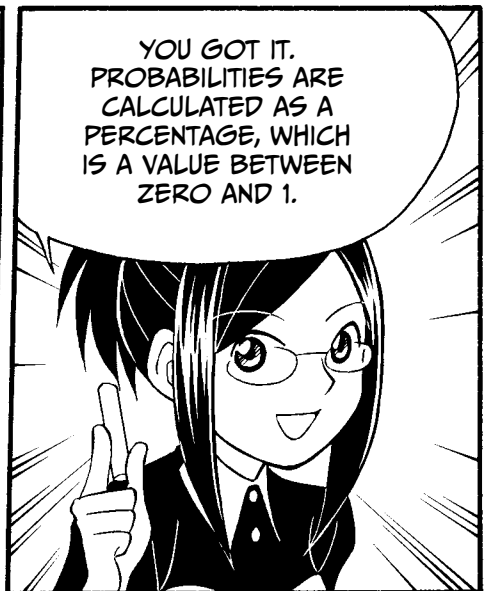
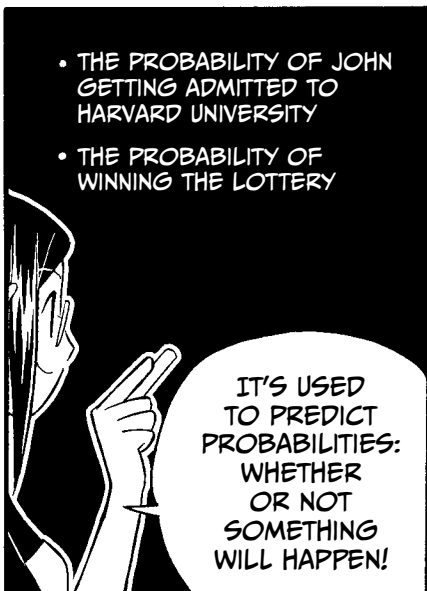
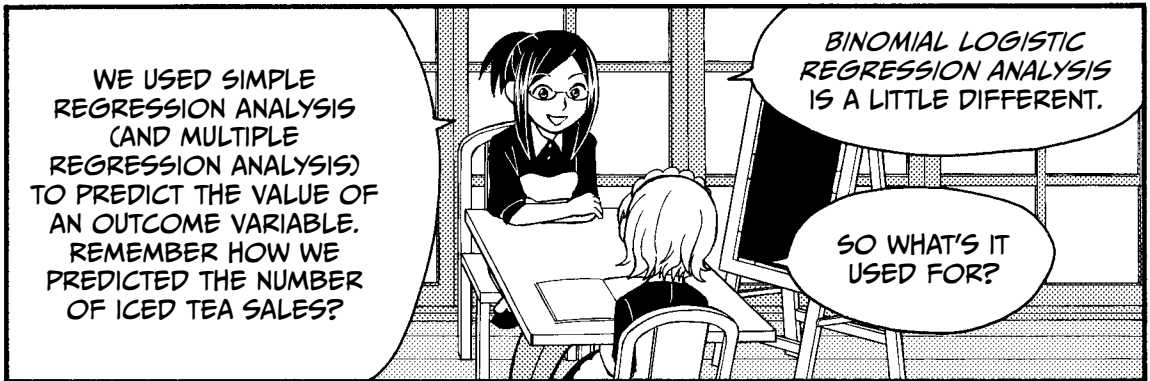
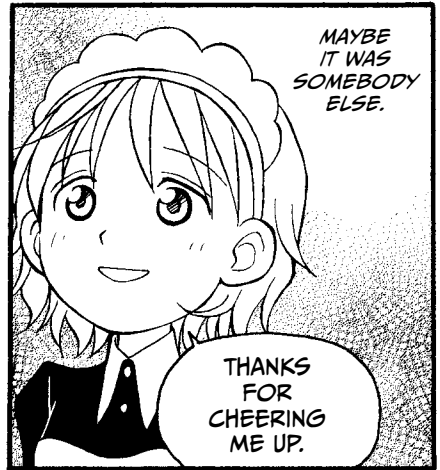
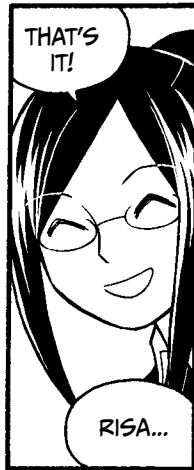

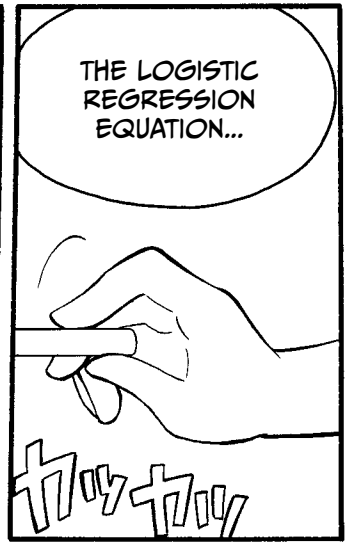
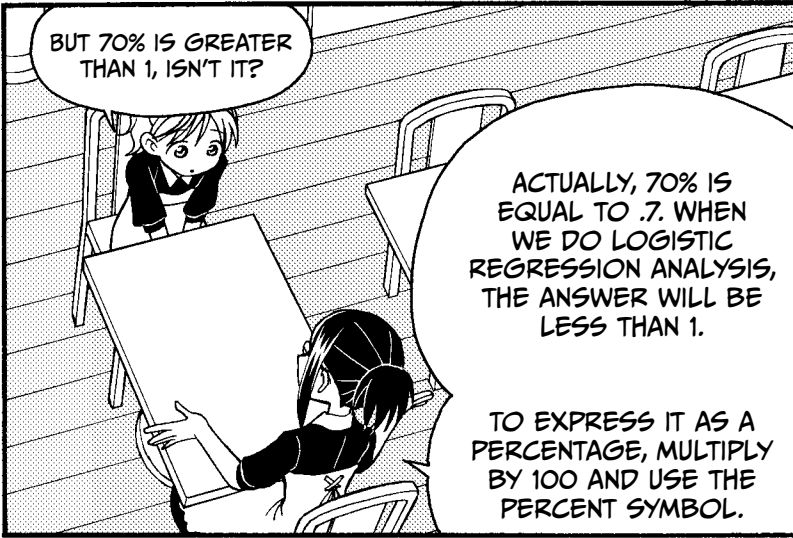

...LOOKS LIKE THIS.

$$y = \frac{1}{1 + e^{-(a_1x_1 + a_2x_2 + \dots + a_px_p + b)}}$$

OUTCOME VARIABLE (y)

PREDICTOR VARIABLE (x)

REGRESSION COEFFICIENT

INTERCEPT



THE GRAPH FOR THE EQUATION LOOKS LIKE THIS:

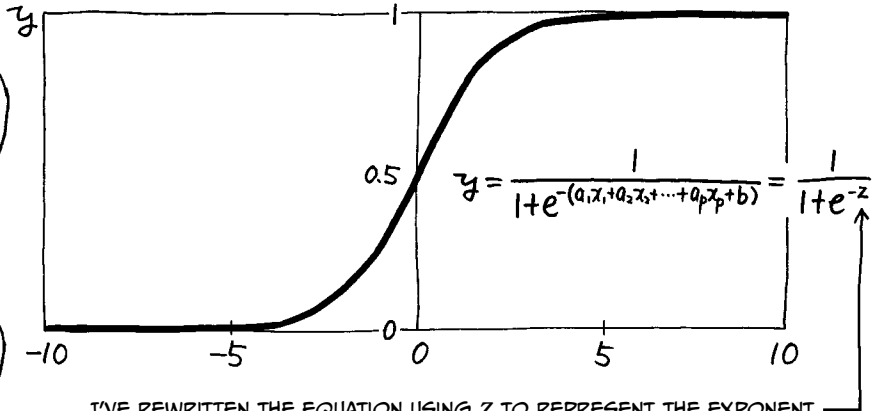

IT'S SHAPED LIKE AN S.

I'VE REWRITTEN THE EQUATION USING Z TO REPRESENT THE EXPONENT. $f(z)$ IS THE PROBABILITY OF OUR OUTCOME!

NO MATTER WHAT Z IS, THE VALUE OF y IS NEVER GREATER THAN 1 OR LESS THAN ZERO.

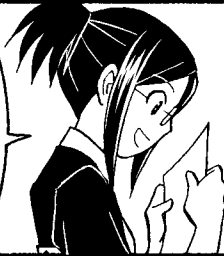

YEAH! IT LOOKS LIKE THE S WAS SMOOSHED TO FIT.

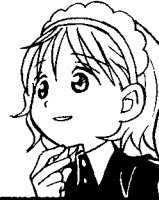

NOW, BEFORE WE CAN GO ANY FURTHER WITH LOGISTIC REGRESSION ANALYSIS, YOU NEED TO UNDERSTAND *MAXIMUM LIKELIHOOD*.



MAXIMUM LIKELIHOOD?

MAXIMUM LIKELIHOOD IS USED TO ESTIMATE THE VALUES OF PARAMETERS OF A POPULATION USING A REPRESENTATIVE SAMPLE. THE ESTIMATES ARE MADE BASED ON PROBABILITY.

MAXIMUM LIKELIHOOD

MORE PROBABILITY!



TO EXPLAIN, I'LL USE A HYPOTHETICAL SITUATION STARRING US!

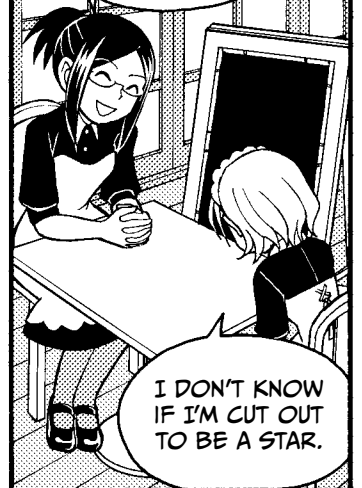

I DON'T KNOW IF I'M CUT OUT TO BE A STAR.

THE MAXIMUM LIKELIHOOD METHOD

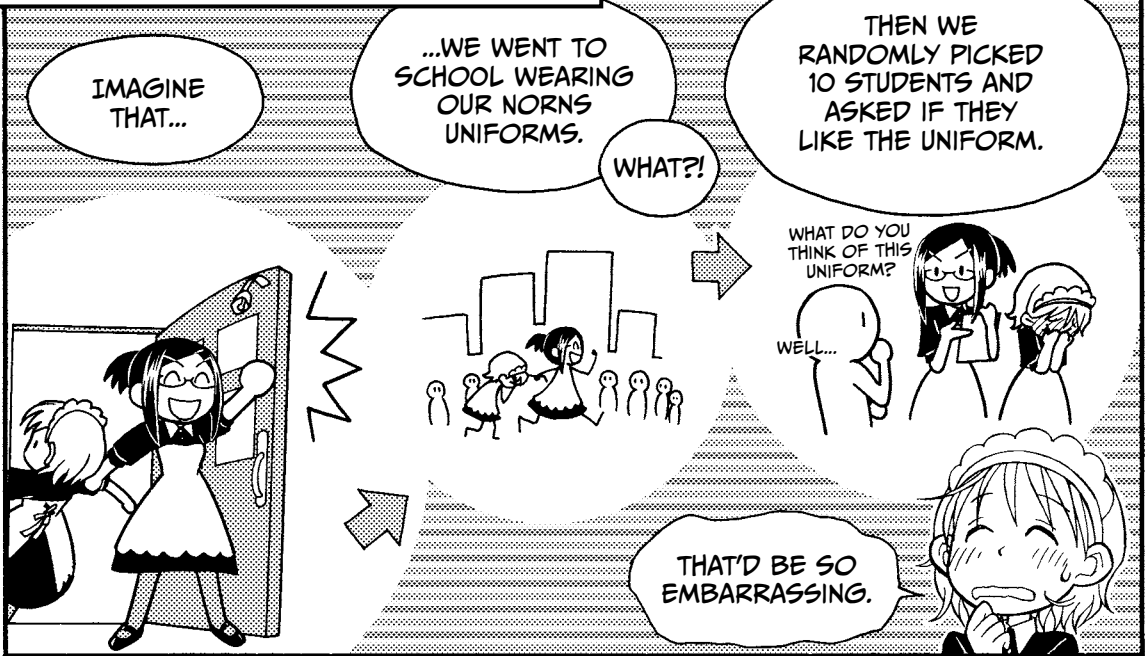

HERE ARE THE IMAGINARY RESULTS.

WOW! MOST PEOPLE SEEM TO LIKE OUR UNIFORM.

STUDENT	DO YOU LIKE THE NORNS UNIFORM?
A	YES
B	NO
C	YES
D	NO
E	YES
F	YES
G	YES
H	YES
I	NO
J	YES

IF THE POPULARITY OF OUR UNIFORMS THROUGHOUT THE ENTIRE STUDENT BODY IS THE PARAMETER p ...

...THEN THE PROBABILITY
BASED ON THE IMAGINARY
SURVEY RESULTS IS THIS:

YES NO YES NO YES YES YES YES NO YES

$$p \times (1-p) \times p \times (1-p) \times p \times p \times p \times p \times (1-p) \times p$$

$$= p^7(1-p)^3$$

IT'S AN
EQUATION?

YES, WE SOLVE IT BY
FINDING THE MOST
LIKELY VALUE OF p .

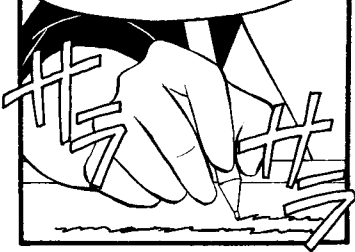

$$p^7(1-p)^3$$

OR

$$\log\{p^7(1-p)^3\}^*$$

WE USE ONE OF
THESE LIKELIHOOD
FUNCTIONS.

EITHER WAY,
THE ANSWER IS
THE SAME.

* TAKING THE LOG OF THIS FUNCTION CAN MAKE LATER CALCULATIONS EASIER.

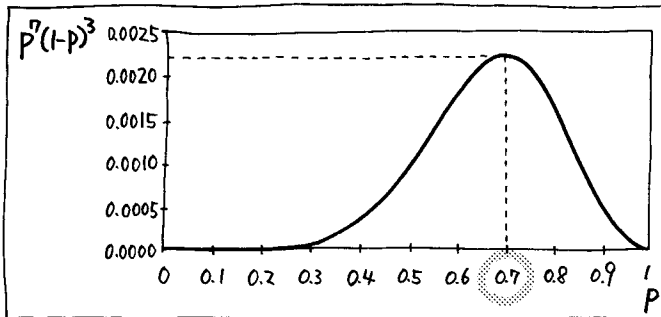

AS YOU CAN SEE, WHEN
WE PLOT THE EQUATIONS,
THEY BOTH PEAK AT .7.
THAT'S THE MOST LIKELY
VALUE FOR p !

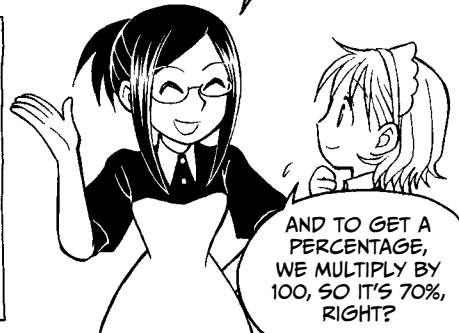
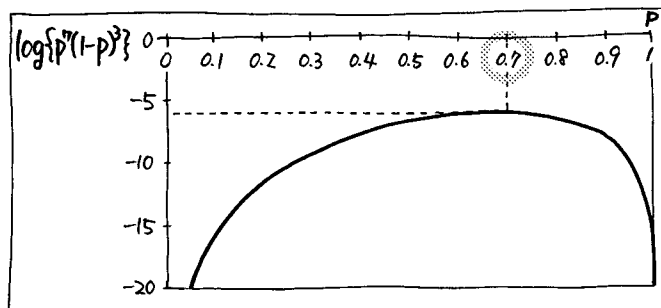

THAT'S RIGHT. WE TAKE THE LOG OF THIS FUNCTION BECAUSE IT MAKES IT EASIER TO CALCULATE THE DERIVATIVE, WHICH WE NEED TO FIND THE MAXIMUM LIKELIHOOD.

$p^n(1-p)^3$
 → LIKELIHOOD FUNCTION

$\log\{p^n(1-p)^3\}$
 → LOG-LIKELIHOOD FUNCTION

IN THE GRAPHS, THIS PEAK IS THE VALUE OF p THAT MAXIMIZES THE VALUE OF THE FUNCTION. IT'S CALLED THE MAXIMUM LIKELIHOOD ESTIMATE.

MAXIMUM LIKELIHOOD ESTIMATE

SO...

...SINCE THE FUNCTIONS PEAK AT THE SAME PLACE, EVEN THOUGH THEY HAVE A DIFFERENT SHAPE, THEY GIVE US THE SAME ANSWER.

EXACTLY!

NOW, LET'S REVIEW THE MAXIMUM LIKELIHOOD ESTIMATE FOR THE POPULARITY OF OUR UNIFORMS.

OKAY, RISA.

FINDING THE MAXIMUM LIKELIHOOD USING THE LIKELIHOOD FUNCTION

Step 1 Find the likelihood function. Here, p stands for Yes, and $1 - p$ stands for No. There were 7 Yeses and 3 Nos.

$$p \times (1 - p) \times p \times (1 - p) \times p \times p \times p \times p \times (1 - p) \times p$$

$$= p^7 (1 - p)^3$$

Step 2 Obtain the log-likelihood function and rearrange it.

$$L = \log \{ p^7 (1 - p)^3 \}$$

$$= \log p^7 + \log (1 - p)^3 \quad \leftarrow \text{Take the log of each component.}$$

$$= 7 \log p + 3 \log (1 - p) \quad \leftarrow \text{Use the Exponentiation Rule from page 22.}$$

WE'LL USE L TO MEAN THE LOG-LIKELIHOOD FUNCTION FROM NOW ON.



Step 3 Differentiate L with respect to p and set the expression equal to 0. Remember that when a function's rate of change is 0, we're finding the maxima.

$$\frac{dL}{dp} = 7 \times \frac{1}{p} + 3 \times \frac{1}{1 - p} \times (-1) = 7 \times \frac{1}{p} - 3 \times \frac{1}{1 - p} = 0$$

Step 4 Rearrange the equation in Step 3 to solve for p .

$$7 \times \frac{1}{p} - 3 \times \frac{1}{1 - p} = 0$$

$$\left(7 \times \frac{1}{p} - 3 \times \frac{1}{1 - p} \right) \times p(1 - p) = 0 \times p(1 - p) \quad \leftarrow \text{Multiply both sides of the equation by } p(1 - p).$$

$$7(1 - p) - 3p = 0$$

$$7 - 7p - 3p = 0$$

$$7 - 10p = 0$$

$$p = \frac{7}{10}$$



AND HERE'S THE
MAXIMUM LIKELIHOOD
ESTIMATE!

YEP, 70%.



CHOOSING PREDICTOR VARIABLES

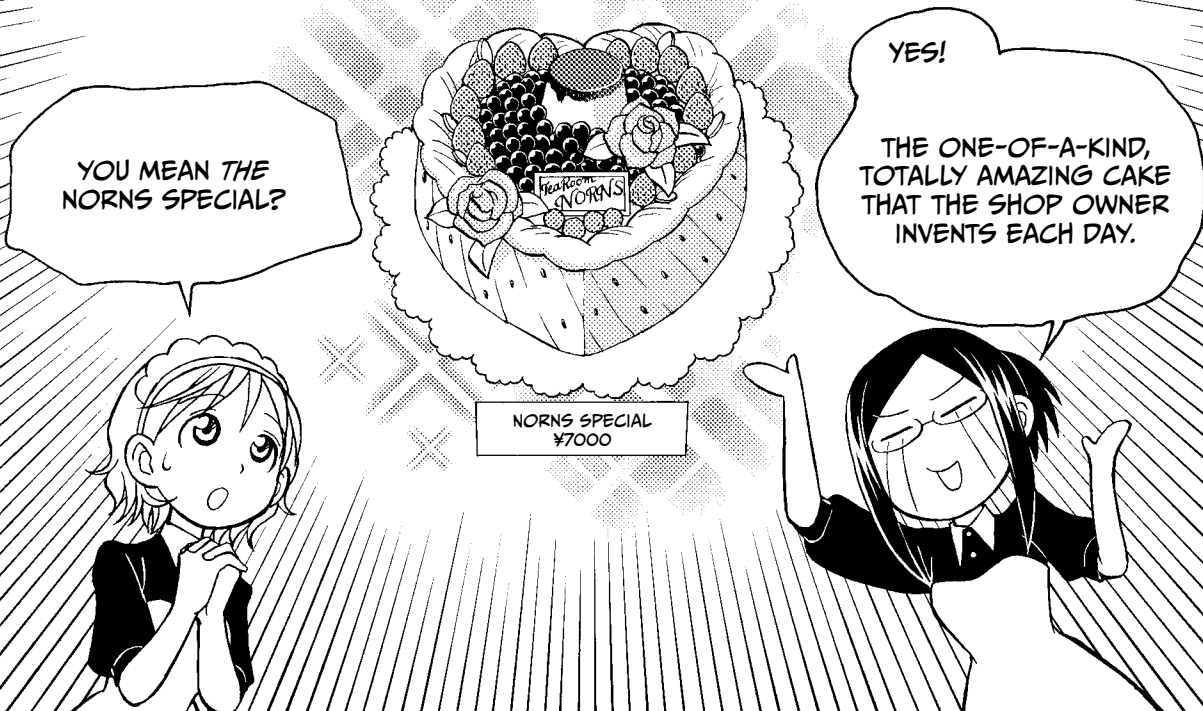
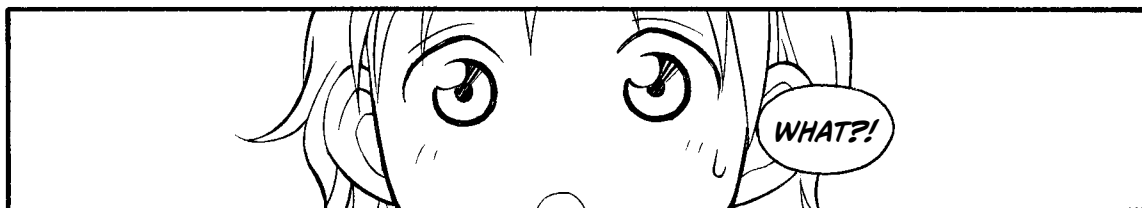
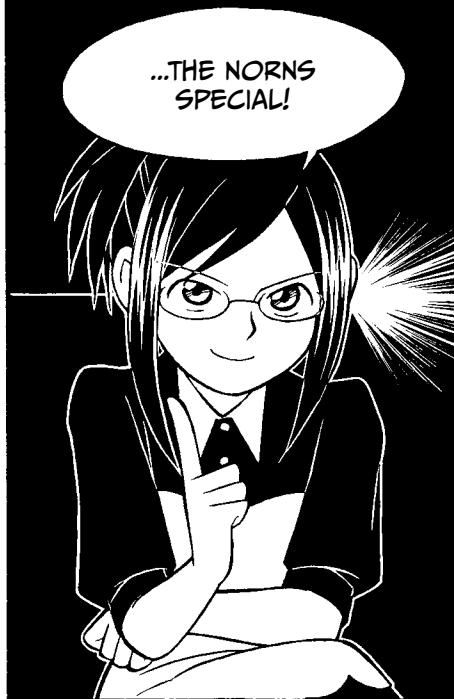
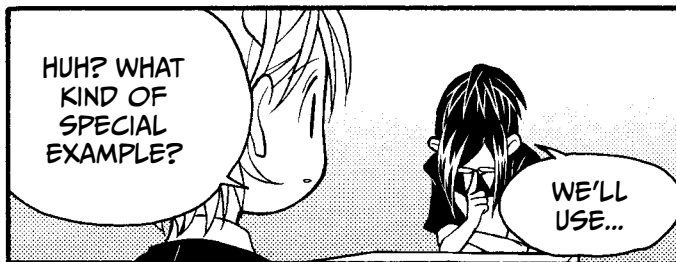
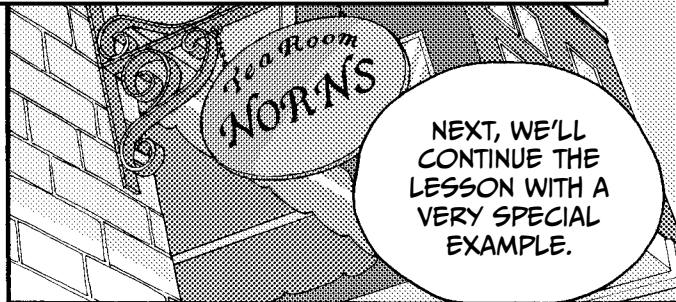

NORNS DOESN'T SELL A SPECIAL CAKE EVERY DAY. PEOPLE ONLY BUY IT FOR A REALLY SPECIAL OCCASION, LIKE A BIRTHDAY.

OR AN ANNIVERSARY...

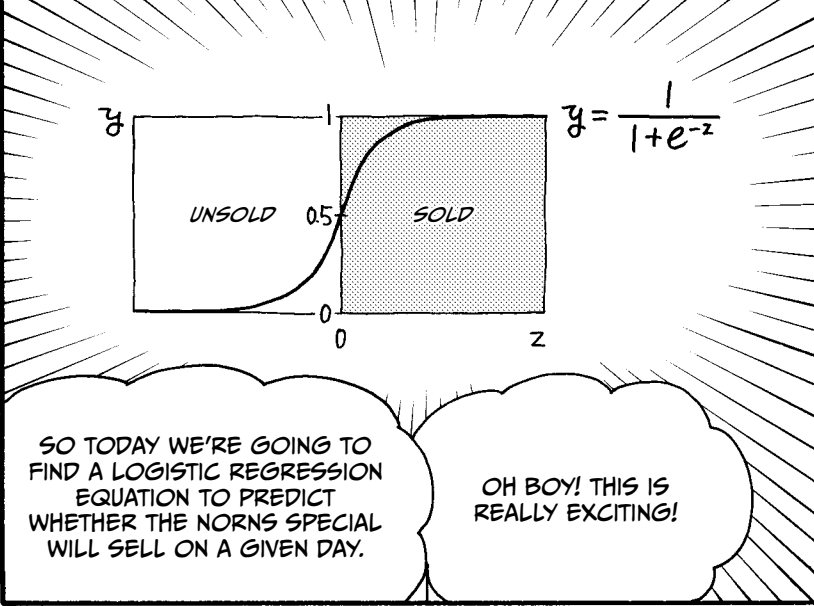

I GUESS WE'LL NEED A DATA SAMPLE. BUT WHAT SHOULD WE MEASURE? WHAT AFFECTS IF IT SELLS OR NOT?

THAT'S A GREAT QUESTION.

I'VE BEEN TRYING TO FIGURE THAT OUT FOR A WHILE. I'VE NOTICED THAT MORE PEOPLE SEEM TO BUY THE NORNS SPECIAL WHEN THE TEMPERATURE IS HIGH, AND ON WEDNESDAYS, SATURDAYS, AND SUNDAYS.

REALLY?

YEP. THERE ARE WAY MORE CUSTOMERS ON THE WEEKEND...

PARTY TIME!

...AND ON WEDNESDAYS, A LARGE MANGA FAN CLUB MEETS HERE, AND THEY REALLY LIKE TO GO BIG.

I'VE BEEN KEEPING RECORDS OF THE SALES AND HIGH TEMPERATURE OVER THE PAST THREE WEEKS.

WOW! YOU DESERVE A RAISE!

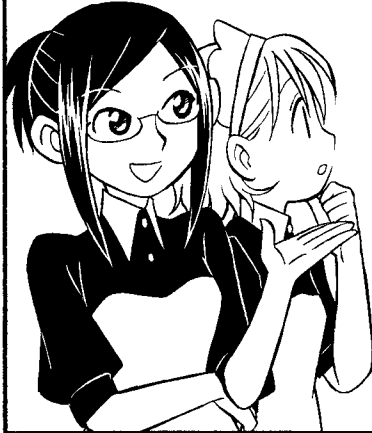

MARCH	WED, SAT, OR SUN	HIGH TEMP (°C)	SALES OF NORNS SPECIAL
5	0	28	1
6	0	24	0
7	1	26	0
8	0	24	0
9	0	23	0
10	1	28	1
11	1	24	0
12	0	26	1
13	0	25	0
14	1	28	1
15	0	21	0
16	0	22	0
17	1	27	1
18	1	26	1
19	0	26	0
20	0	21	0
21	1	21	1
22	0	27	0
23	0	23	0
24	1	22	0
25	1	24	1

1 MEANS WEDNESDAY, SATURDAY, OR SUNDAY. 0 MEANS OTHER DAYS.

1 MEANS IT WAS SOLD. 0 MEANS IT WAS NOT SOLD.

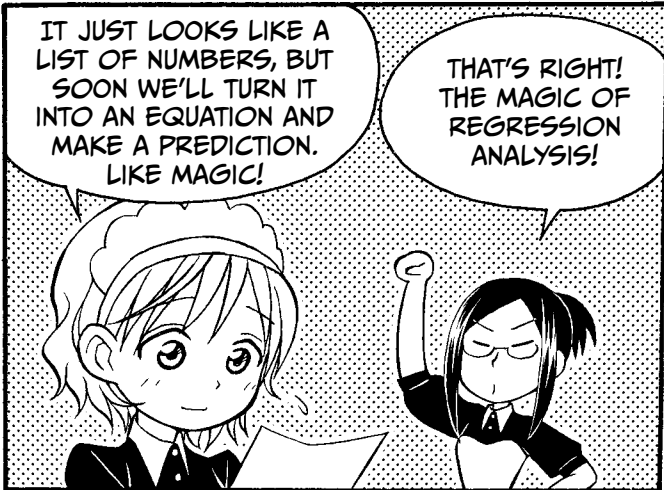

IT JUST LOOKS LIKE A LIST OF NUMBERS, BUT SOON WE'LL TURN IT INTO AN EQUATION AND MAKE A PREDICTION. LIKE MAGIC!

THAT'S RIGHT! THE MAGIC OF REGRESSION ANALYSIS!

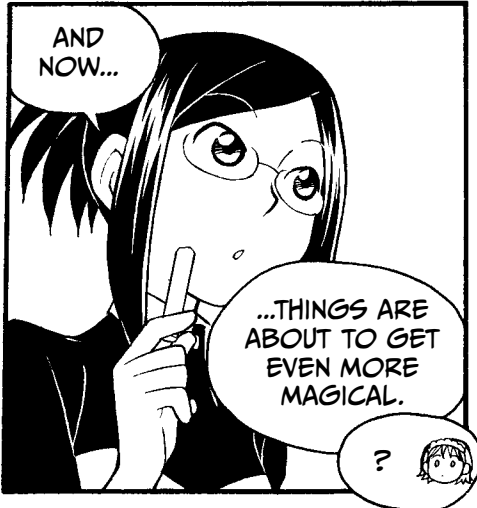

AND NOW...

...THINGS ARE ABOUT TO GET EVEN MORE MAGICAL.



WE USED 1 TO MEAN
SOLD AND 0 TO
MEAN UNSOLD...

1 = SOLD

0 = UNSOLD

...WHICH IS HOW
WE REPRESENT
CATEGORICAL
DATA AS
NUMBERS, RIGHT?

RIGHT.

WELL, IN LOGISTIC REGRESSION ANALYSIS,
THESE NUMBERS AREN'T JUST LABELS—
THEY ACTUALLY MEASURE THE PROBABILITY
THAT THE CAKE WAS SOLD. THAT'S
BECAUSE 1 MEANS 100% AND 0 MEANS 0%.

OH! SINCE WE
KNOW IT WAS SOLD,
THERE'S A 100%
PROBABILITY THAT
IT WAS SOLD.

WE ALSO
KNOW FOR
SURE IF IT WAS
WEDNESDAY,
SATURDAY, OR
SUNDAY.

WE SURE
DO.

IN THIS CASE, HIGH TEMPERATURE
IS MEASURABLE DATA, SO WE
USE THE TEMPERATURE, JUST
LIKE IN LINEAR REGRESSION
ANALYSIS. CATEGORICAL DATA
ALSO WORKS IN BASICALLY
THE SAME WAY AS IN LINEAR
REGRESSION ANALYSIS, AND
ONCE AGAIN WE CAN USE ANY
COMBINATION OF CATEGORICAL
AND NUMERICAL DATA.

BUT CATEGORICAL
DATA CAN HAVE
MEASURABLE
PROBABILITIES.

LOGISTIC REGRESSION ANALYSIS IN ACTION!

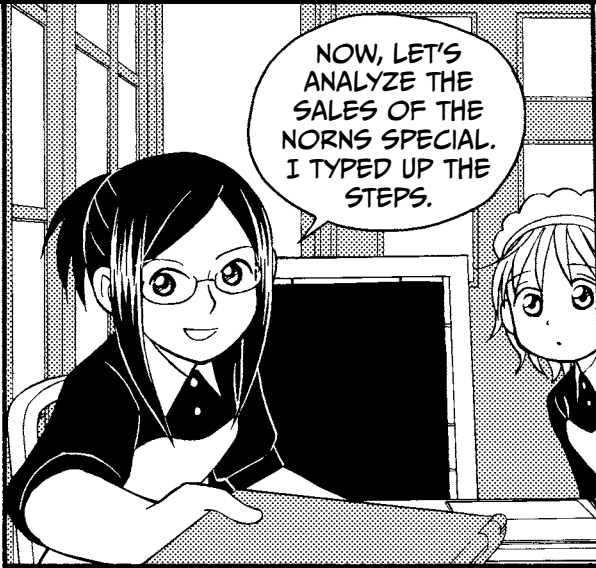

NOW, LET'S ANALYZE THE SALES OF THE NORNS SPECIAL. I TYPED UP THE STEPS.

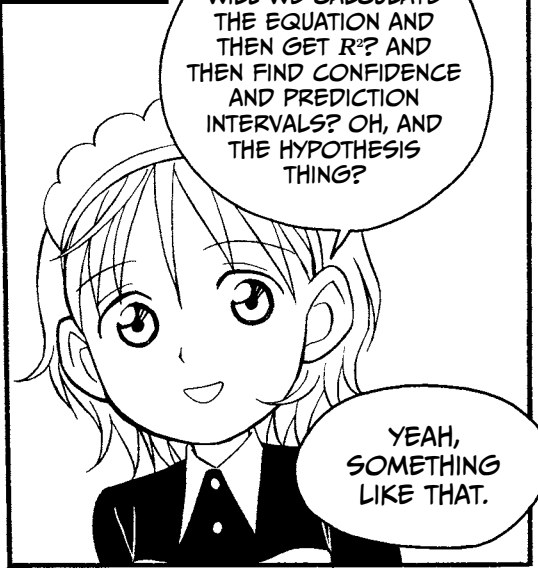

WILL WE CALCULATE THE EQUATION AND THEN GET R^2 ? AND THEN FIND CONFIDENCE AND PREDICTION INTERVALS? OH, AND THE HYPOTHESIS THING?

YEAH, SOMETHING LIKE THAT.

LOGISTIC REGRESSION ANALYSIS PROCEDURE

STEP 1

DRAW A SCATTER PLOT OF THE PREDICTOR VARIABLES AND THE OUTCOME VARIABLE TO SEE WHETHER THEY APPEAR TO BE RELATED.

STEP 2

CALCULATE THE LOGISTIC REGRESSION EQUATION.

STEP 3

ASSESS THE ACCURACY OF THE EQUATION.

STEP 4

CONDUCT THE HYPOTHESIS TESTS.

STEP 5

MAKE A PREDICTION!

HERE ARE THE FIVE BASIC STEPS OF LOGISTIC REGRESSION ANALYSIS.

THAT'S NOT SO DIFFERENT.

STEP 1: DRAW A SCATTER PLOT OF THE PREDICTOR VARIABLES AND THE OUTCOME VARIABLE TO SEE WHETHER THEY APPEAR TO BE RELATED.

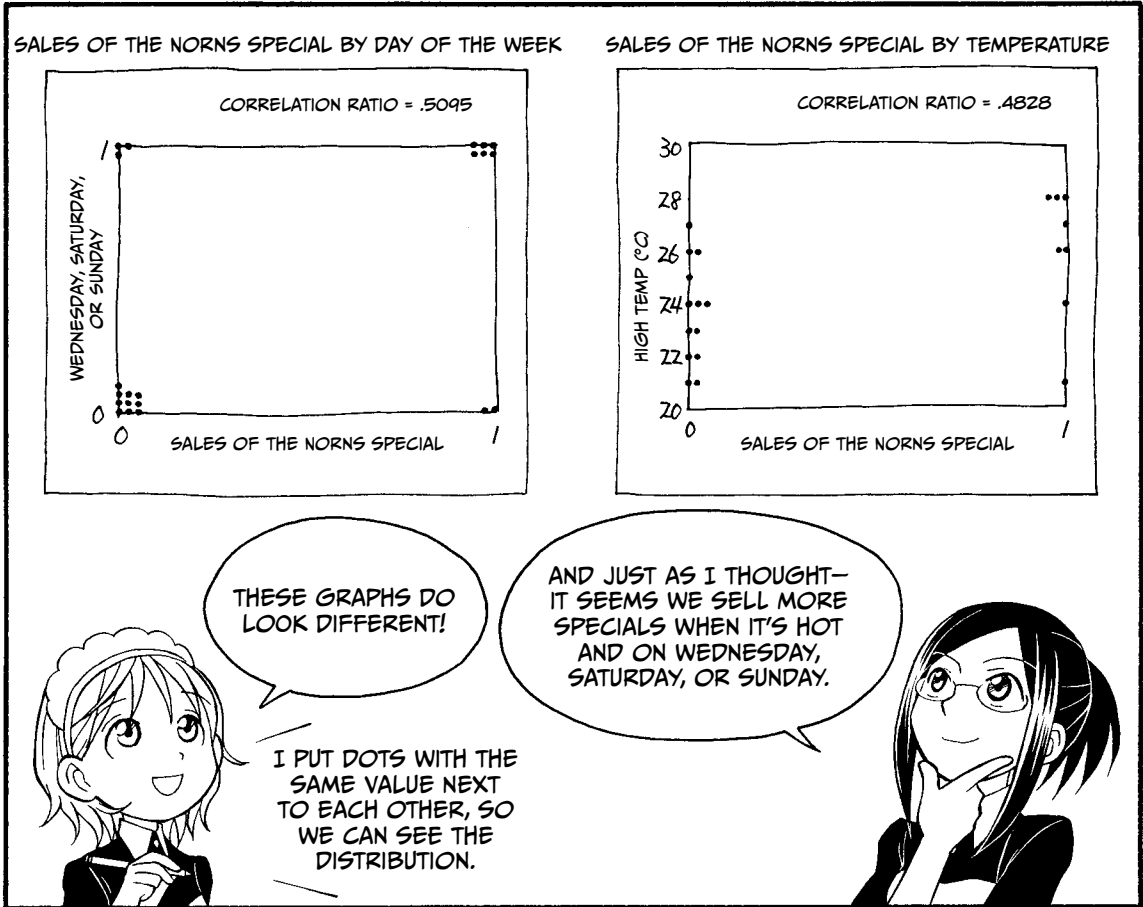
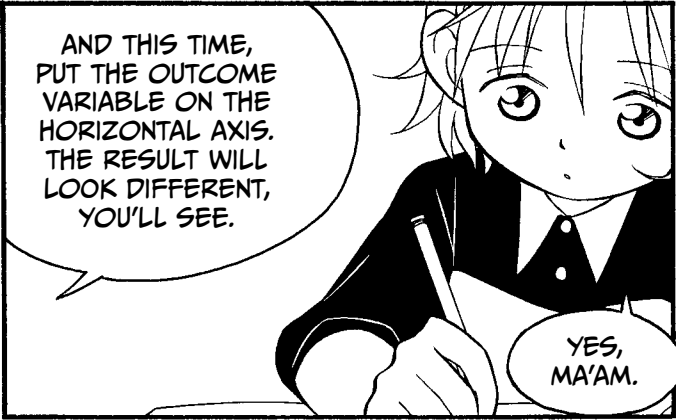

STEP 2: CALCULATE THE LOGISTIC REGRESSION EQUATION.

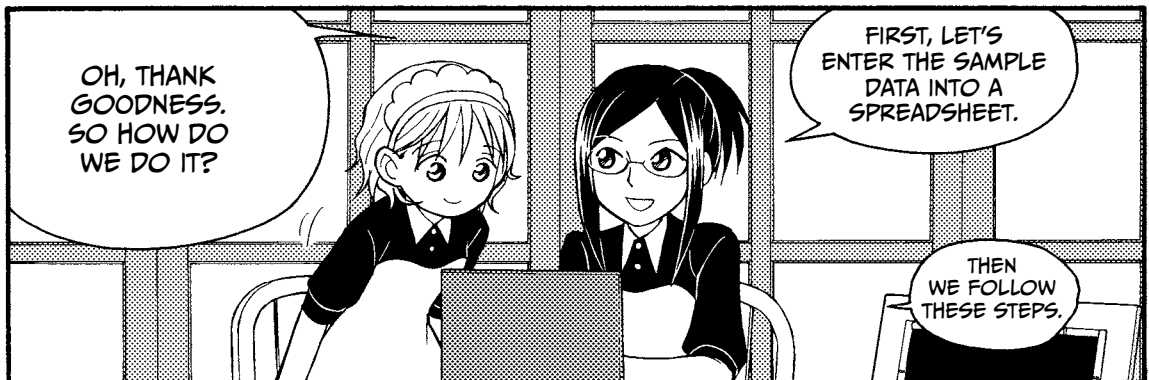
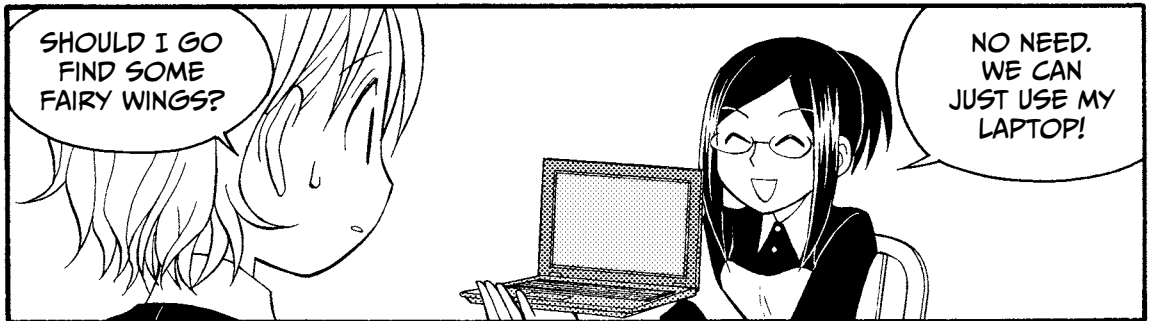
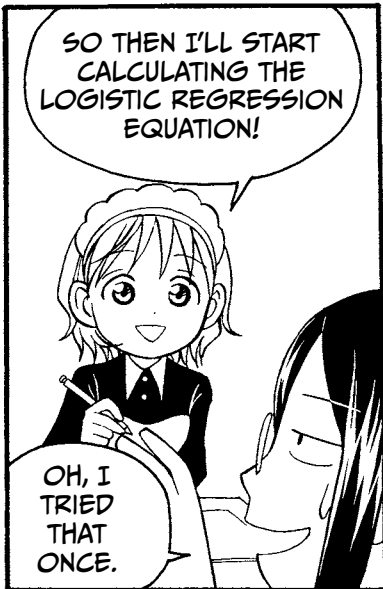

Step 1

Determine the binomial logistic equation for each sample.

Wednesday, Saturday, or Sunday	High temperature	Sales of the Norns special y	Sales of the Norns special $\hat{y} = \frac{1}{1 + e^{-(a_1x_1 + a_2x_2 + b)}}$
x_1	x_2		
0	28	1	$\frac{1}{1 + e^{-(a_1 \times 0 + a_2 \times 28 + b)}}$
0	24	0	$\frac{1}{1 + e^{-(a_1 \times 0 + a_2 \times 24 + b)}}$
:	:	:	:
1	24	0	$\frac{1}{1 + e^{-(a_1 \times 1 + a_2 \times 24 + b)}}$

Step 2

Obtain the likelihood function. The equation from Step 1 represents a sold cake, and (1 - the equation) represents an unsold cake.

$$\frac{1}{1 + e^{-(a_1 \times 0 + a_2 \times 28 + b)}} \times \left(1 - \frac{1}{1 + e^{-(a_1 \times 0 + a_2 \times 24 + b)}}\right) \times \dots \times \frac{1}{1 + e^{-(a_1 \times 1 + a_2 \times 24 + b)}}$$

Sold

Unsold

Sold

Step 3

Take the natural log to find the log-likelihood function, L .

$$L = \log_e \left[\frac{1}{1 + e^{-(a_1 \times 0 + a_2 \times 28 + b)}} \times \left(1 - \frac{1}{1 + e^{-(a_1 \times 0 + a_2 \times 24 + b)}}\right) \times \dots \times \frac{1}{1 + e^{-(a_1 \times 1 + a_2 \times 24 + b)}} \right]$$

$$= \log_e \left(\frac{1}{1 + e^{-(a_1 \times 0 + a_2 \times 28 + b)}} \right) + \log_e \left(1 - \frac{1}{1 + e^{-(a_1 \times 0 + a_2 \times 24 + b)}} \right) + \dots + \log_e \left(\frac{1}{1 + e^{-(a_1 \times 1 + a_2 \times 24 + b)}} \right)$$

Step4

Find the maximum likelihood coefficients. These coefficients maximize log-likelihood function L .

The values are:*

$$\begin{cases} a_1 = 2.44 \\ a_2 = 0.54 \\ b = -15.20 \end{cases}$$



We can plug these values into the likelihood function to calculate L , which we'll use to calculate R^2 .

$$\begin{aligned} L &= \log_e \left(\frac{1}{1 + e^{-(2.44 \times 0 + 0.54 \times 28 - 15.20)}} \right) + \log_e \left(1 - \frac{1}{1 + e^{-(2.44 \times 0 + 0.54 \times 24 - 15.20)}} \right) + \dots + \log_e \left(\frac{1}{1 + e^{-(2.44 \times 1 + 0.54 \times 24 - 15.20)}} \right) \\ &= -8.9 \end{aligned}$$

*See page 210 for a more detailed explanation of these calculations.

Step5

Calculate the logistic regression equation.

We fill in the coefficients calculated in Step 4 to get the following logistic regression equation:

$$y = \frac{1}{1 + e^{-(2.44x_1 + 0.54x_2 - 15.20)}}$$

SO THIS IS THE EQUATION THAT WE CAN USE TO PREDICT WHETHER WE'LL SELL TODAY'S SPECIAL!

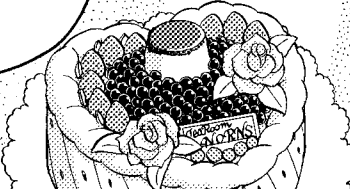

$$y = \frac{1}{1 + e^{-(2.44x_1 + 0.54x_2 - 15.20)}}$$

YEP, THIS IS IT.

STEP 3: ASSESS THE ACCURACY OF THE EQUATION.

NOW WE NEED TO MAKE SURE THAT THE EQUATION IS A GOOD FIT FOR OUR DATA.

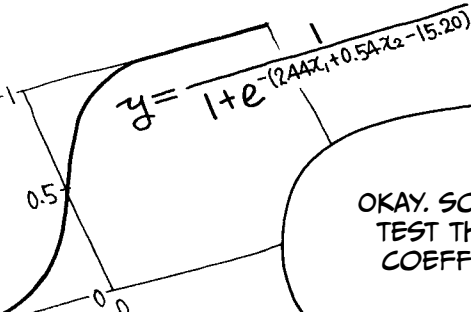

OKAY. SO WE FIND R^2 AND TEST THE REGRESSION COEFFICIENTS, RIGHT?

THAT'S RIGHT, ALTHOUGH LOGISTIC REGRESSION ANALYSIS WORKS SLIGHTLY DIFFERENTLY.



HUH? HOW COME?

IN LOGISTIC REGRESSION ANALYSIS, WE CALCULATE A PSEUDO- R^2 *



IT'S FAKE?

* IN THIS EXAMPLE, WE USE MCFADDEN'S PSEUDO- R^2 FORMULA.

HERE'S THE EQUATION THAT WE USE TO CALCULATE R^2 IN LOGISTIC REGRESSION ANALYSIS.

$$R^2 = 1 - \frac{\text{MAXIMUM VALUE OF LOG-LIKELIHOOD FUNCTION } L}{n_1 \log n_1 + n_0 \log n_0 - (n_1 + n_0) \log (n_1 + n_0)}$$

ACK!!! IT'S SO LONG!



THE n VARIABLES ARE A TALLY OF THE CAKES THAT ARE SOLD (n_1) OR UNSOLD (n_0).

n_1	THE NUMBER OF DATA POINTS WHOSE OUTCOME VARIABLE'S VALUE IS 1
n_0	THE NUMBER OF DATA POINTS WHOSE OUTCOME VARIABLE'S VALUE IS 0

AND HERE'S A MORE GENERAL DEFINITION.

I'M STILL NOT SURE HOW TO USE THIS EQUATION WITH THE NORN'S SPECIAL DATA.

DON'T WORRY, IT'S NOT THAT HARD.

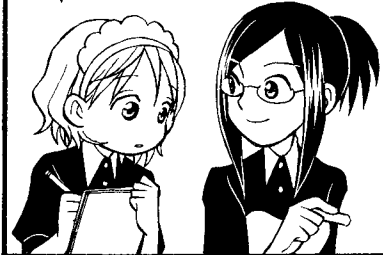

WE JUST FILL IN THE NUMBERS FOR THE NORN'S SPECIAL...

$$R^2 = 1 - \frac{\text{MAXIMUM VALUE OF LOG-LIKELIHOOD FUNCTION } L}{n_1 \log n_1 + n_0 \log n_0 - (n_1 + n_0) \log (n_1 + n_0)}$$

$$= 1 - \frac{-8.9}{8 \log 8 + 13 \log 13 - (8 + 13) \log (8 + 13)}$$

$$= .3622$$

WHOA, I WASN'T EXPECTING THAT.

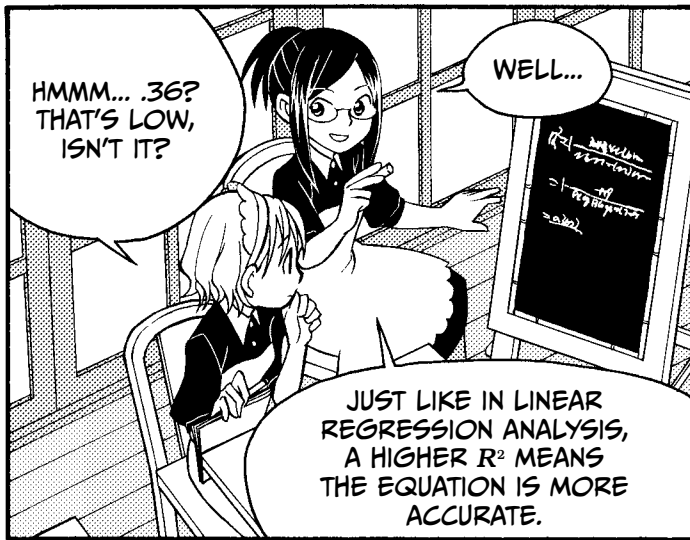

HMMM... .36?
THAT'S LOW,
ISN'T IT?

WELL...

JUST LIKE IN LINEAR
REGRESSION ANALYSIS,
A HIGHER R^2 MEANS
THE EQUATION IS MORE
ACCURATE.



BUT THERE'S NO SET
RULE FOR HOW HIGH
 R^2 NEEDS TO BE,
RIGHT?

THAT'S
TRUE.

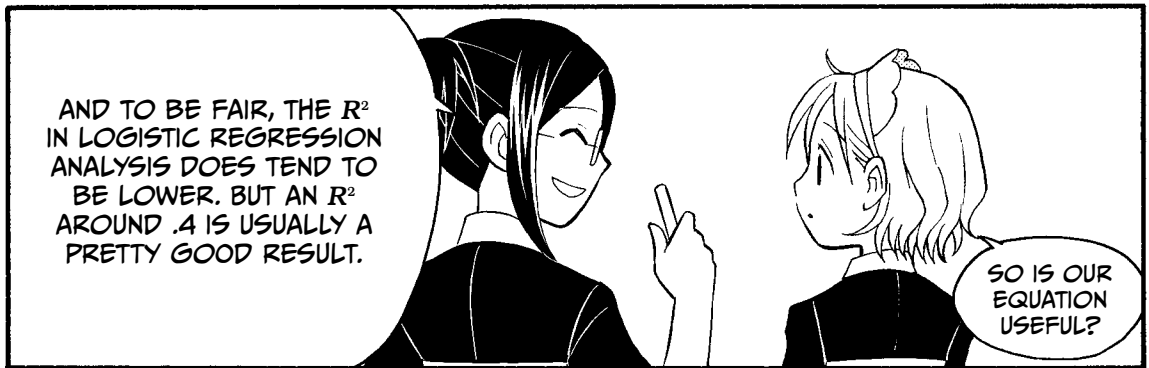

AND TO BE FAIR, THE R^2
IN LOGISTIC REGRESSION
ANALYSIS DOES TEND TO
BE LOWER. BUT AN R^2
AROUND .4 IS USUALLY A
PRETTY GOOD RESULT.

SO IS OUR
EQUATION
USEFUL?

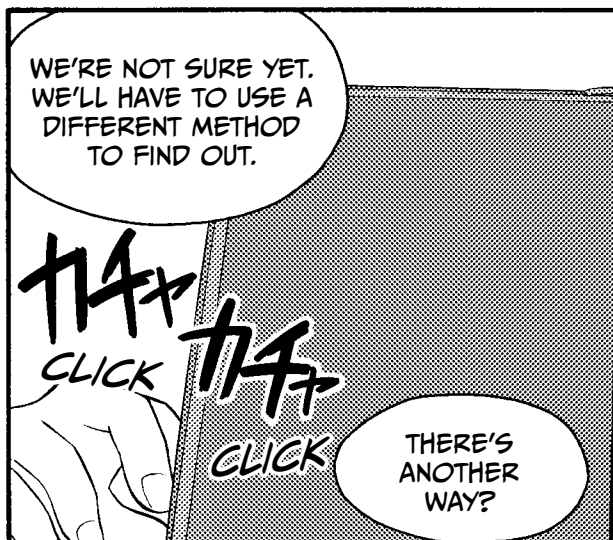

WE'RE NOT SURE YET.
WE'LL HAVE TO USE A
DIFFERENT METHOD
TO FIND OUT.

THERE'S
ANOTHER
WAY?

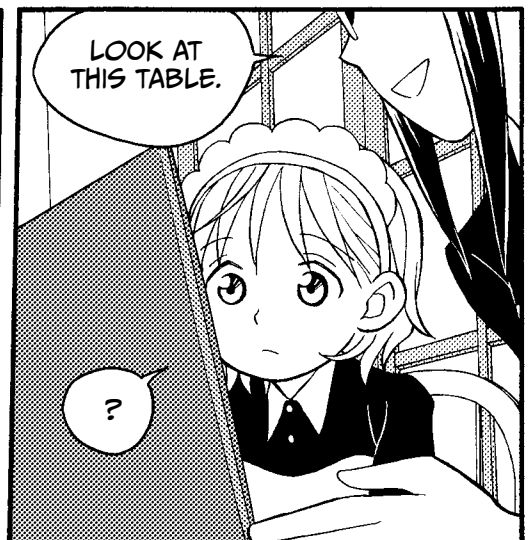

LOOK AT
THIS TABLE.

?

Wednesday,				
Saturday, or		High temp.		
Day	Sunday	(°C)	Actual sales	Predicted sales
	x_1	x_2	y	\hat{y}
5	0	28	1	.51 sold
6	0	24	0	.11 unsold
7	1	26	0	.80 sold
8	0	24	0	.11 unsold
9	0	23	0	.06 unsold
10	1	28	1	.92 sold
11	1	24	0	.58 sold
12	0	26	1	.26 unsold
13	0	25	0	.17 unsold
14	1	28	1	.92 sold
15	0	21	0	.02 unsold
16	0	22	0	.04 unsold
17	1	27	1	.87 sold
18	1	26	1	.80 sold
19	0	26	0	.26 unsold
20	0	21	0	.02 unsold
21	1	21	1	.21 unsold
22	0	27	0	.38 unsold
23	0	23	0	.06 unsold
24	1	22	0	.31 unsold
25	1	24	1	.58 sold

THIS TABLE SHOWS THE ACTUAL SALES DATA FOR THE NORNS SPECIAL AND OUR PREDICTION. IF THE PREDICTION IS GREATER THAN .50, WE SAY IT SOLD.

BUT THE TABLE SHOWS SOMETHING ELSE. CAN YOU SEE IT?

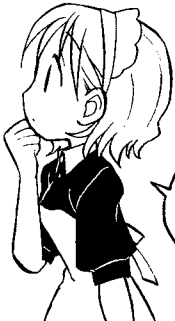

HMM...

WELL...

$$\frac{1}{1 + e^{-(2.44 \times 1 + 0.54 \times 24 - 15.20)}} = .58$$

FOR ONE THING, THE NORNS SPECIAL DID NOT SELL ON THE 7TH AND THE 11TH, EVEN THOUGH WE PREDICTED THAT IT WOULD.

Day	y	\hat{y}
7	0	.80 sold
11	0	.58 sold

GREAT! ANYTHING ELSE?

ON THE 12TH AND THE 21ST, WE PREDICTED THAT IT WOULDN'T SELL, BUT IT DID! WE CAN SEE WHERE THE EQUATION WAS WRONG.

BRILLIANT!

BEST STUDENT EVER!

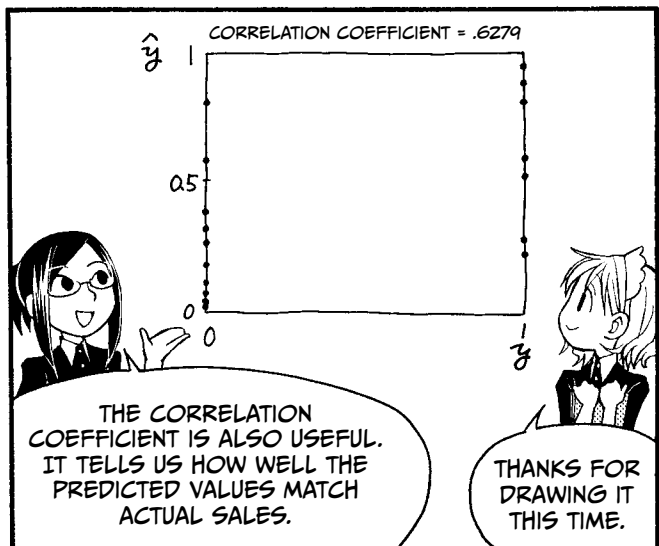
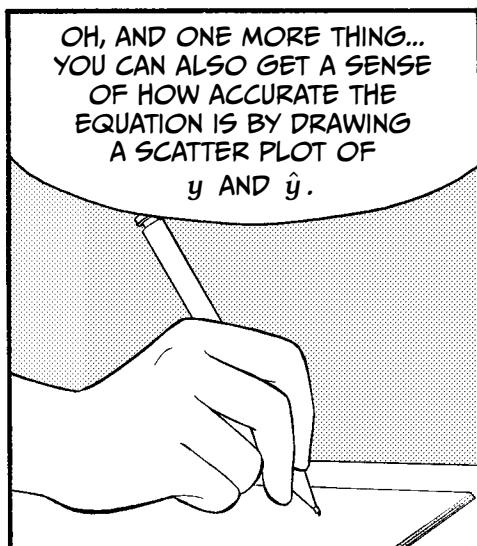
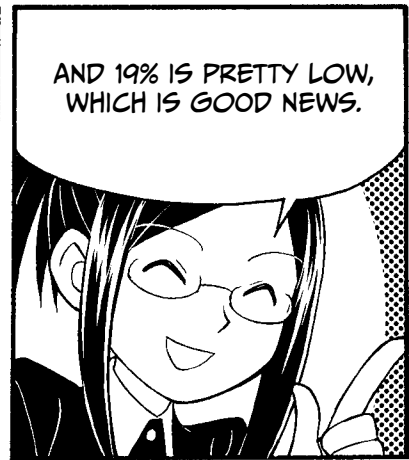
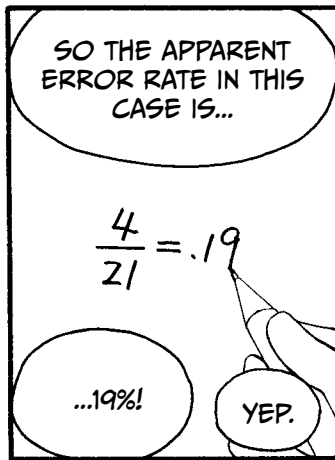
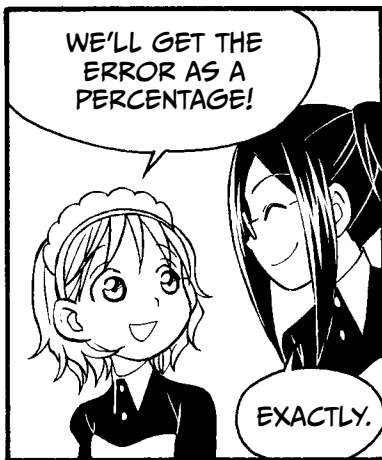
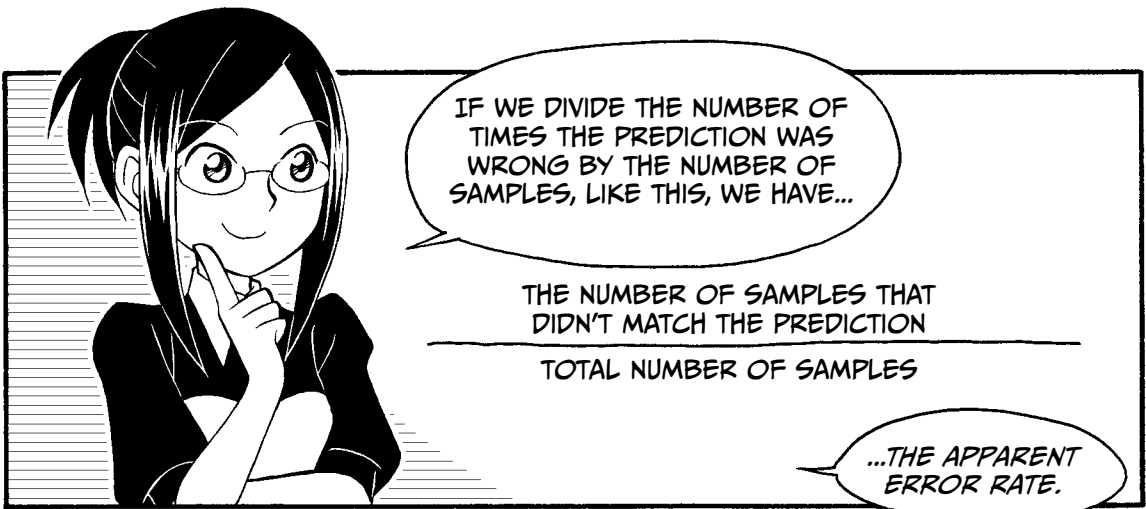

STEP 4: CONDUCT THE HYPOTHESIS TESTS.

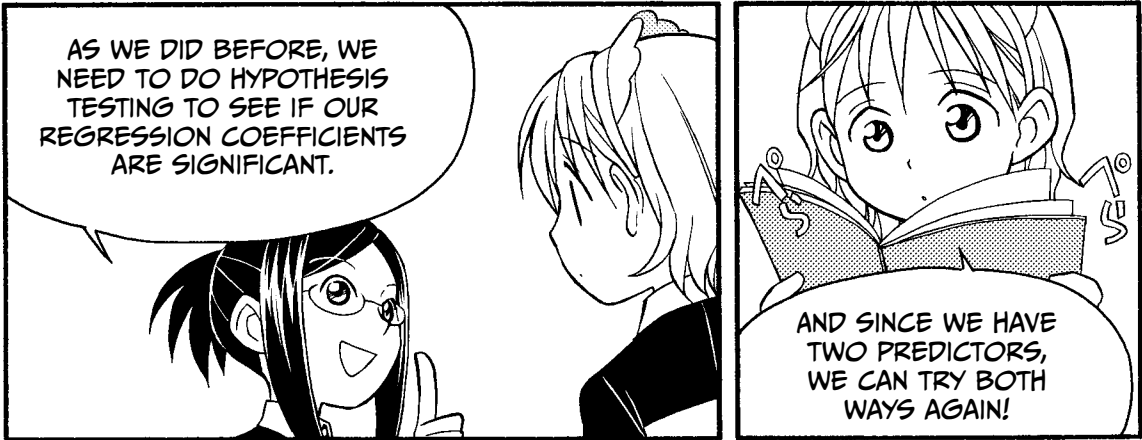

COMPREHENSIVE HYPOTHESIS TEST		HYPOTHESIS TEST FOR AN INDIVIDUAL REGRESSION COEFFICIENT	
NULL HYPOTHESIS	$A_1 = A_2 = 0$	NULL HYPOTHESIS	$A_i = 0$
ALTERNATIVE HYPOTHESIS	ONE OF THE FOLLOWING IS TRUE: <ul style="list-style-type: none"> • $A_1 \neq 0$ AND $A_2 \neq 0$ • $A_1 \neq 0$ AND $A_2 = 0$ • $A_1 = 0$ AND $A_2 \neq 0$ 	ALTERNATIVE HYPOTHESIS	$A_i \neq 0$

RIGHT.

LIKE THIS.

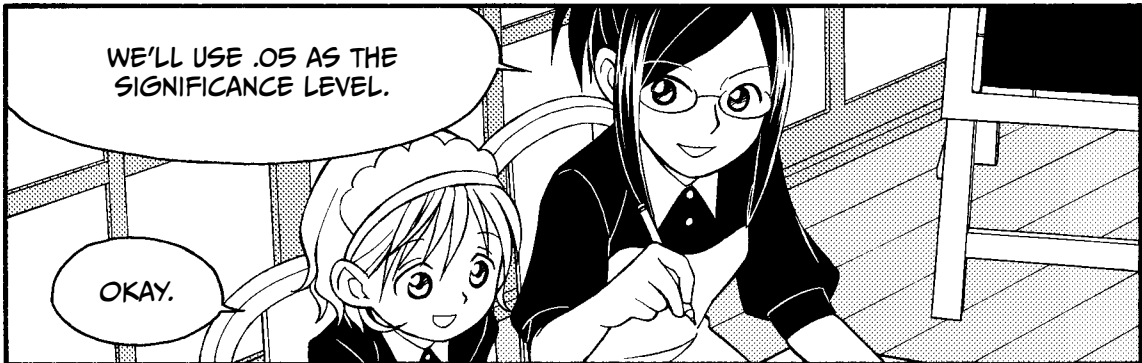

WE'LL DO THE LIKELIHOOD RATIO TEST. THIS TEST LETS US EXAMINE ALL THE COEFFICIENTS AT ONCE AND ASSESS THE RELATIONSHIPS AMONG THE COEFFICIENTS.



THE STEPS OF THE LIKELIHOOD RATIO TEST

Step 1	Define the populations.	All days the Norns Special is sold, comparing Wednesdays, Saturdays, and Sundays against the remaining days, at each high temperature.
Step 2	Set up a null hypothesis and an alternative hypothesis.	Null hypothesis is $A_1 = 0$ and $A_2 = 0$. Alternative hypothesis is $A_1 \neq 0$ or $A_2 \neq 0$.
Step 3	Select which hypothesis test to conduct.	We'll perform the likelihood ratio test.
Step 4	Choose the significance level.	We'll use a significance level of .05.
Step 5	Calculate the test statistic from the sample data.	The test statistic is: $2[L - n_1 \log_e(n_1) - n_0 \log_e(n_0) + (n_1 + n_0) \log_e(n_1 + n_0)]$ When we plug in our data, we get: $2[-8.9010 - 8 \log_e 8 - 13 \log_e 13 + (8 + 13) \log_e (8 + 13)]$ $= 10.1$ <p>The test statistic follows a chi-squared distribution with 2 degrees of freedom (the number of predictor variables), if the null hypothesis is true.</p>
Step 6	Determine whether the p -value for the test statistic obtained in Step 5 is smaller than the significance level.	The significance level is .05. The value of the test statistic is 10.1, so the p -value is .006. Finally, $.006 < .05$.*
Step 7	Decide whether you can reject the null hypothesis.	Since the p -value is smaller than the significance level, we reject the null hypothesis.

* How to obtain the p -value in a chi-squared distribution is explained on page 205.

NEXT, WE'LL USE THE WALD TEST TO SEE WHETHER EACH OF OUR PREDICTOR VARIABLES HAS A SIGNIFICANT EFFECT ON THE SALE OF THE NORNS SPECIAL. WE'LL DEMONSTRATE USING DAYS OF THE WEEK.

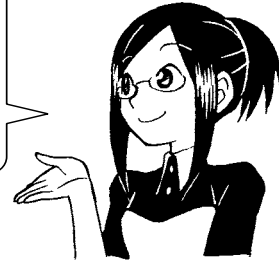

THE STEPS OF THE WALD TEST

Step 1	Define the population.	All days the Norns Special is sold, comparing Wednesdays, Saturdays, and Sundays against the remaining days, at each high temperature.
Step 2	Set up a null hypothesis and an alternative hypothesis.	Null hypothesis is $A = 0$. Alternative hypothesis is $A \neq 0$.
Step 3	Select which hypothesis test to conduct.	Perform the Wald test.
Step 4	Choose the significance level.	We'll use a significance level of .05.
Step 5	Calculate the test statistic from the sample data.	The test statistic for the Wald test is $\frac{\alpha_1^2}{S_{11}}$
		In this example, the value of the test statistic is: $\frac{2.44^2}{1.5475} = 3.9$
		The test statistic will follow a chi-squared distribution with 1 degree of freedom, if the null hypothesis is true.
Step 6	Determine whether the p -value for the test statistic obtained in Step 5 is smaller than the significance level.	The value of the test statistic is 3.9, so the p -value is .0489. You can see that $.0489 < .05$, so the p -value is smaller.
Step 7	Decide whether you can reject the null hypothesis.	Since the p -value is smaller than the significance level, we reject the null hypothesis.

IN SOME REFERENCES, THIS PROCESS IS EXPLAINED USING NORMAL DISTRIBUTION INSTEAD OF CHI-SQUARED DISTRIBUTION. THE FINAL RESULT WILL BE THE SAME NO MATTER WHICH METHOD YOU CHOOSE.



This is how we calculate the standard error matrix. The values of this matrix are used to calculate the Wald test statistic in Step 5 on page 180.

High temperature

Wednesday, Saturday, or Sunday

$$= \begin{pmatrix} 0 & 0 & \dots & 1 \\ 28 & 24 & \dots & 24 \\ \vdots & \vdots & \ddots & \vdots \\ 1 & 1 & \dots & 1 \end{pmatrix} \begin{pmatrix} (\hat{y} \text{ on the 5th}) \times (1 - \hat{y} \text{ on the 5th}) & 0 & \dots & 0 \\ 0 & (\hat{y} \text{ on the 6th}) \times (1 - \hat{y} \text{ on the 6th}) & \dots & 0 \\ \vdots & \vdots & \ddots & \vdots \\ 0 & 0 & \dots & (\hat{y} \text{ on the 25th}) \times (1 - \hat{y} \text{ on the 25th}) \end{pmatrix} \begin{pmatrix} 0 & 28 & 1 \\ 0 & 24 & 1 \\ \vdots & \vdots & \vdots \\ 1 & 24 & 1 \end{pmatrix}^{-1}$$

These 1s represent an immeasurable constant. In other words, they are a placeholder.

$$= \begin{pmatrix} 0 & 0 & \dots & 1 \\ 28 & 24 & \dots & 24 \\ 1 & 1 & \dots & 1 \end{pmatrix} \begin{pmatrix} 0.51 \times 0.49 & 0 & \dots & 0 \\ 0 & 0.11 \times 0.89 & \dots & 0 \\ \vdots & \vdots & \ddots & \vdots \\ 0 & 0 & \dots & 0.58 \times 0.42 \end{pmatrix} \begin{pmatrix} 0 & 28 & 1 \\ 0 & 24 & 1 \\ \vdots & \vdots & \vdots \\ 1 & 24 & 1 \end{pmatrix}^{-1}$$

$$= \begin{pmatrix} 1.5388 & \dots & \dots \\ \dots & 0.881 & \dots \\ \dots & \dots & \dots \end{pmatrix}$$

S_{11} in Step 5 is this... ...and this is S_{22} .

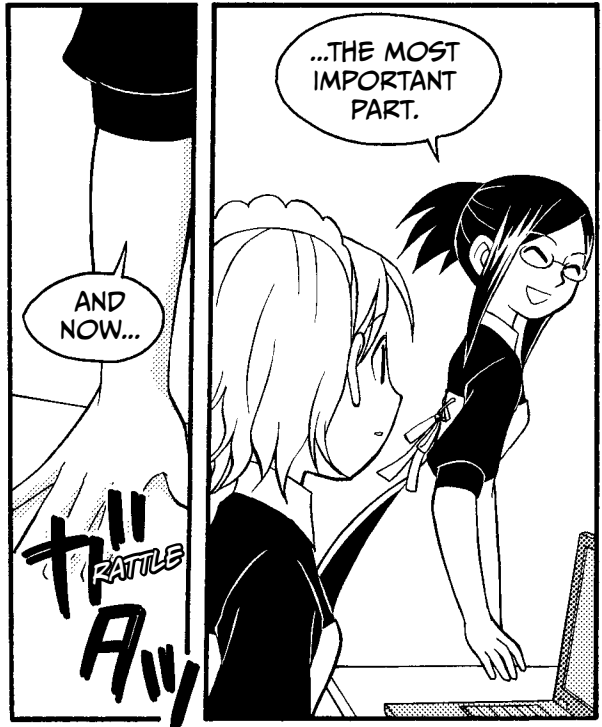
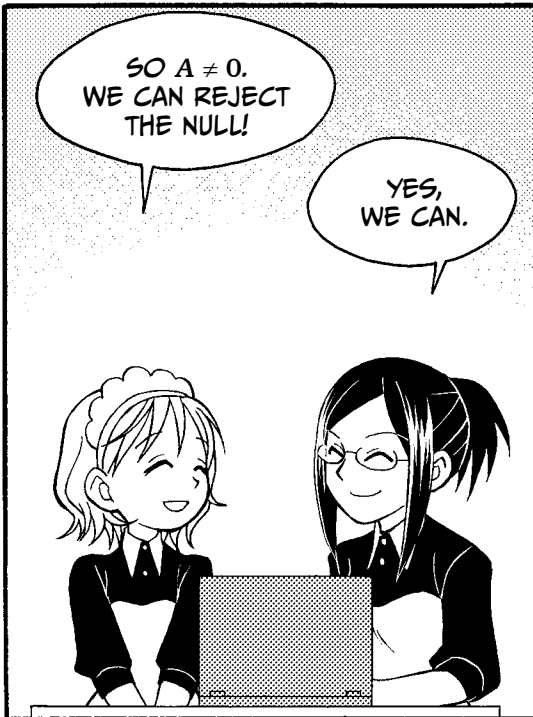

STEP 5: PREDICT WHETHER THE NORNS SPECIAL WILL SELL.

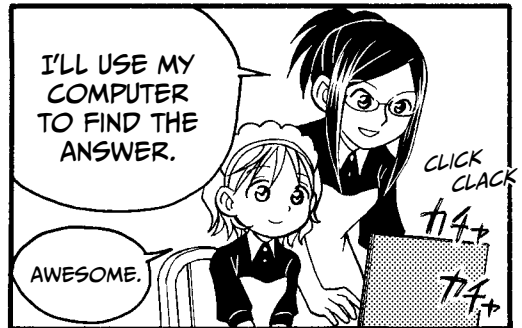
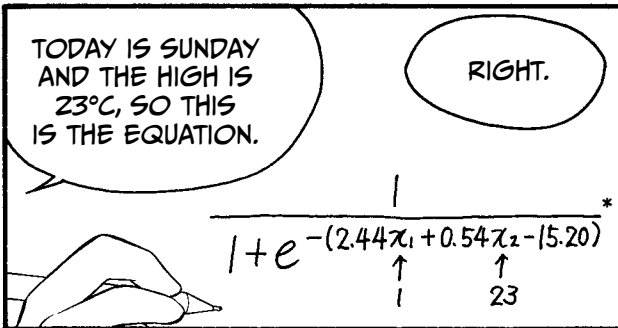
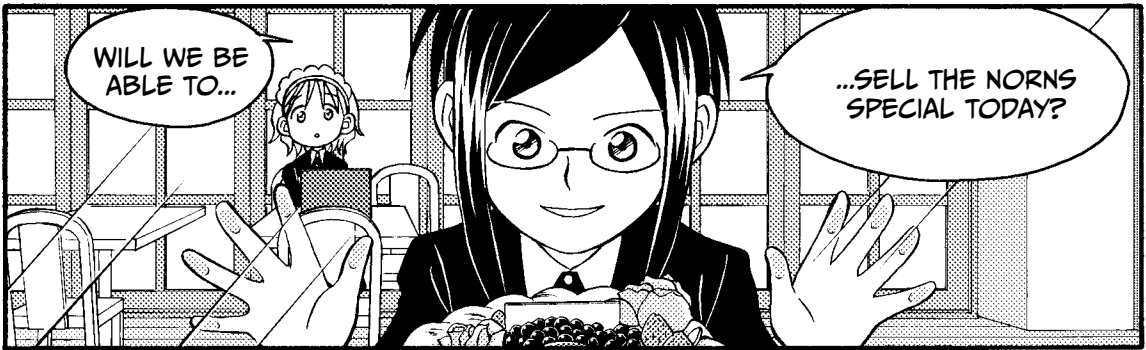

* THIS CALCULATION WAS MADE USING ROUNDED NUMBERS. IF YOU USE THE FULL, UNROUNDED NUMBERS, THE RESULT WILL BE .44.

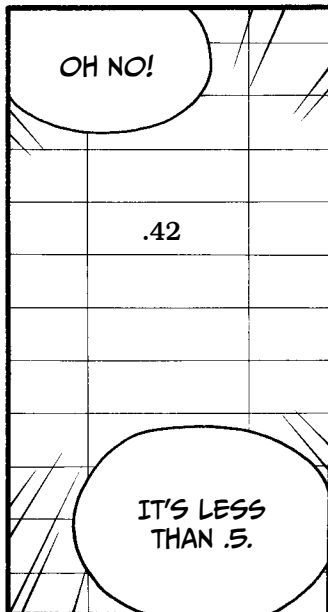

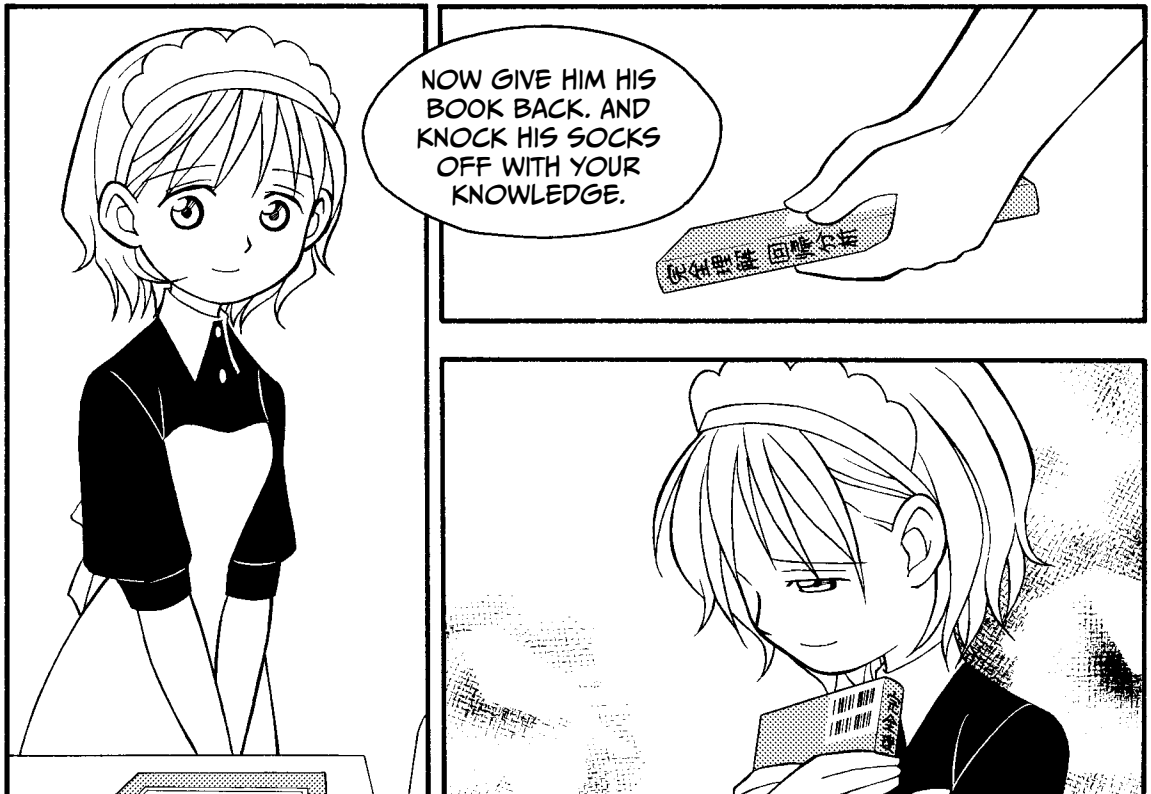
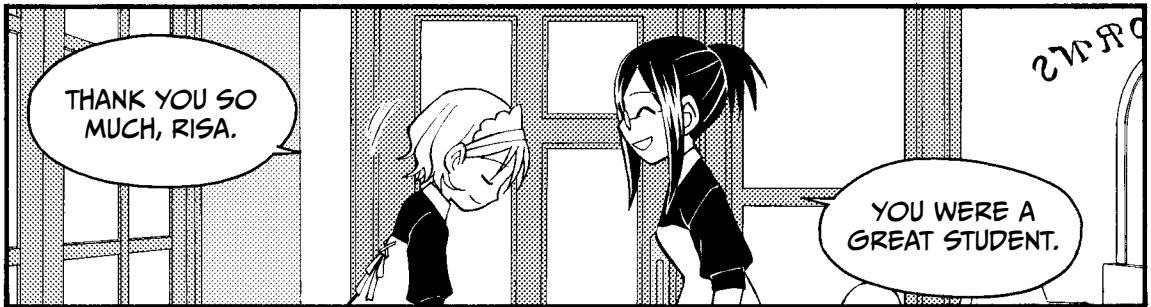
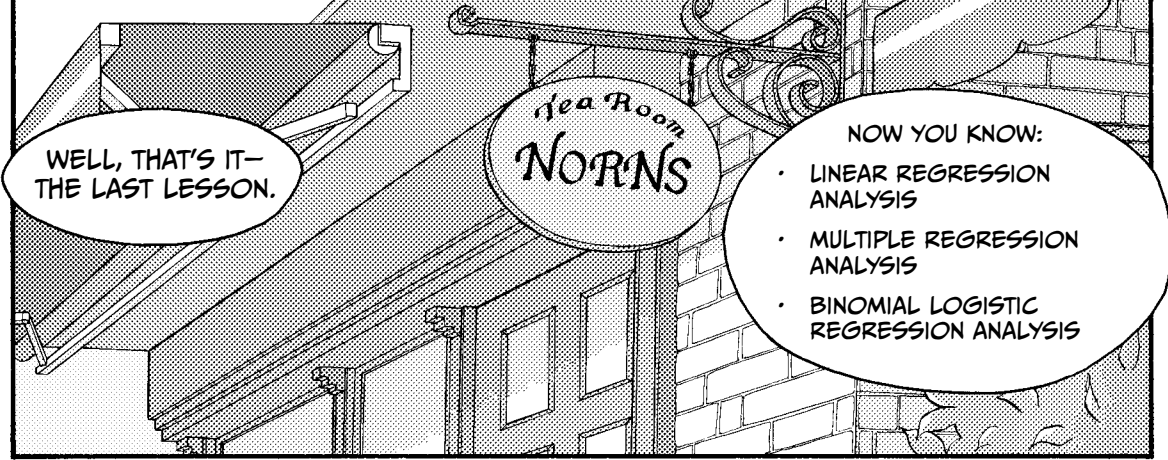

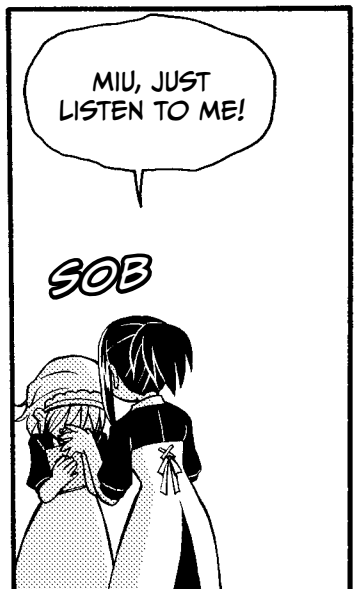
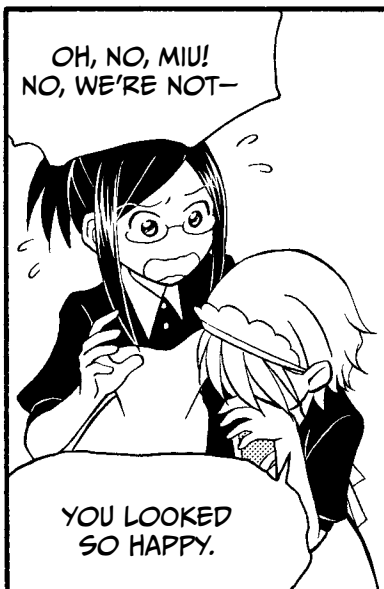
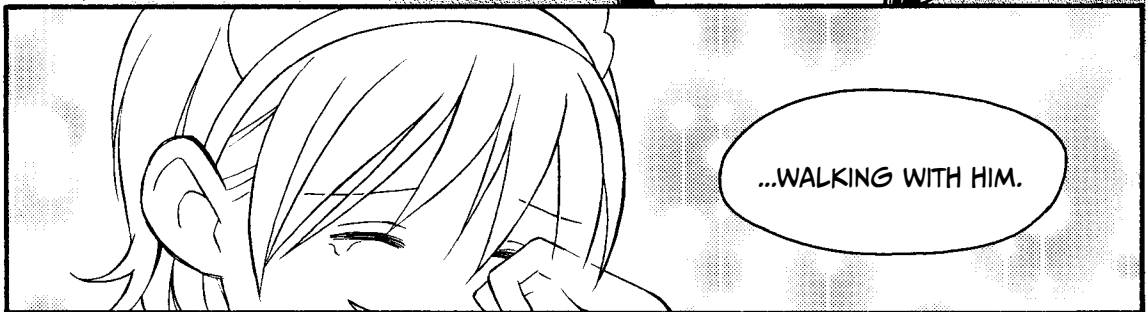
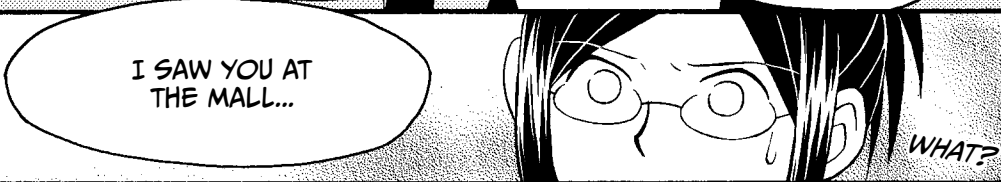
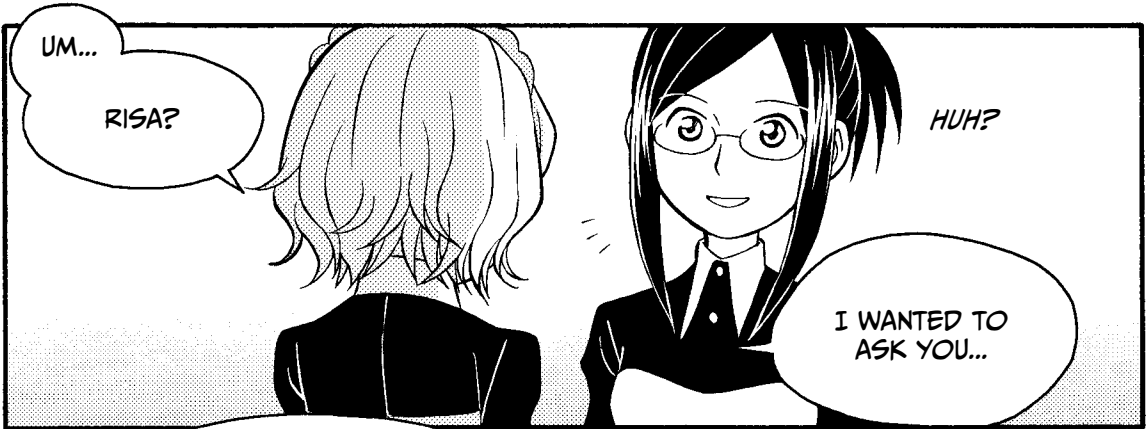

HELLO?

IS THE SHOP
OPEN YET?

HIROTO!

YOU KNOW
HIS NAME...?

あわわ...

MIU...

LET ME
INTRODUCE YOU
TO HIROTO...

MY COUSIN.

COUSIN...?

RISA!

YES, MIU?

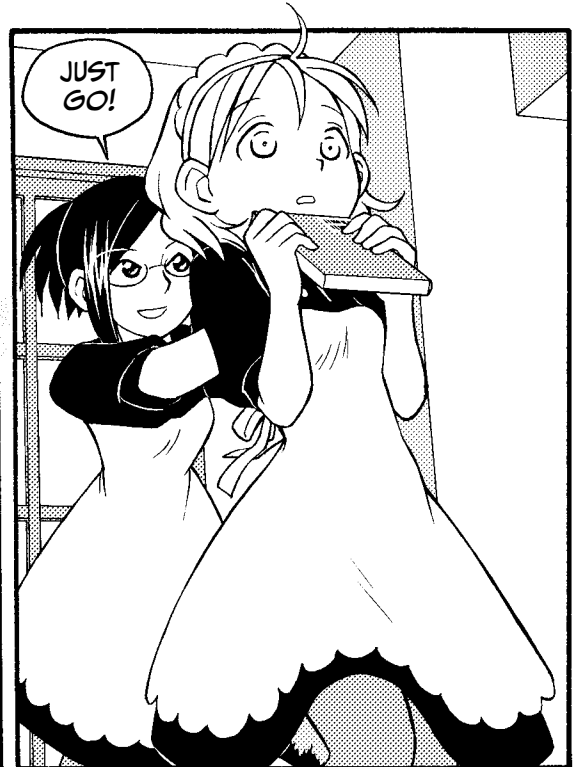
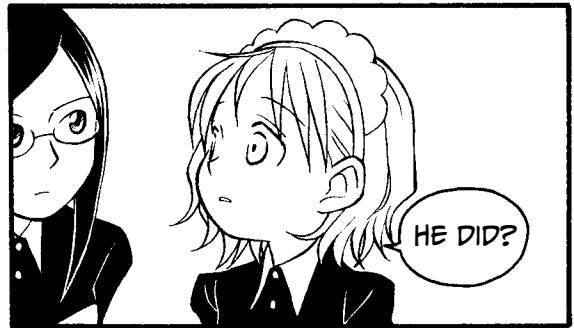
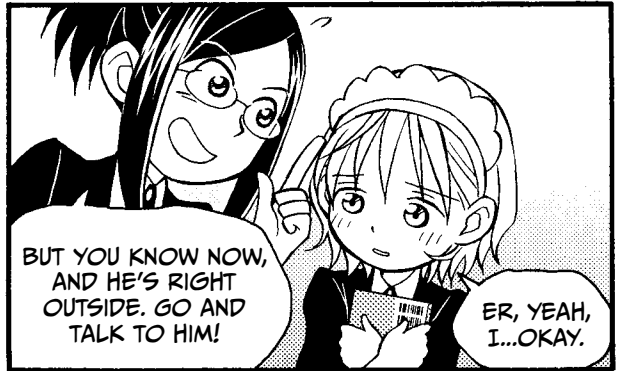
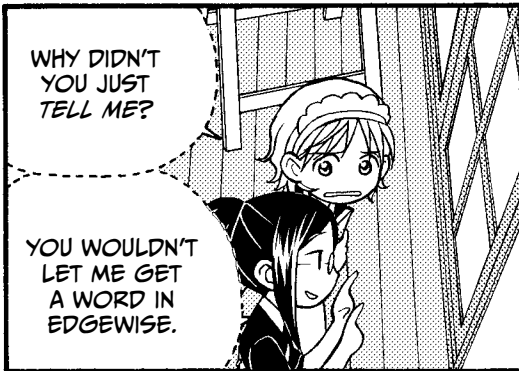

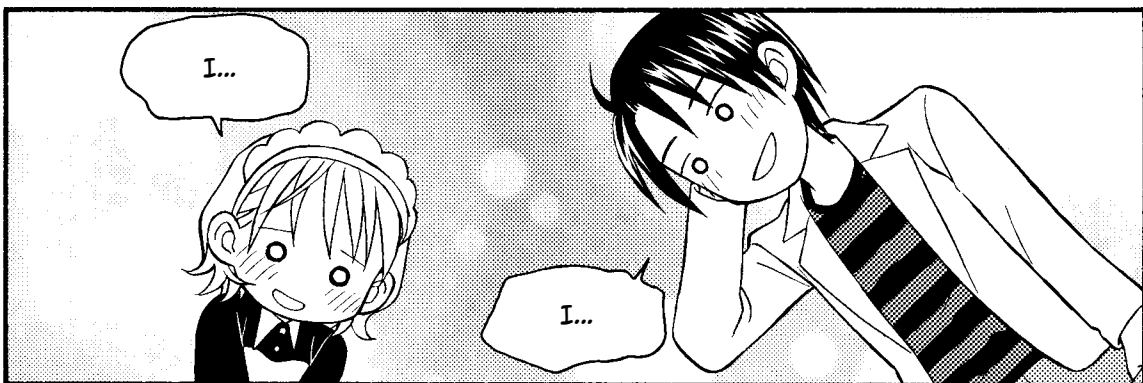
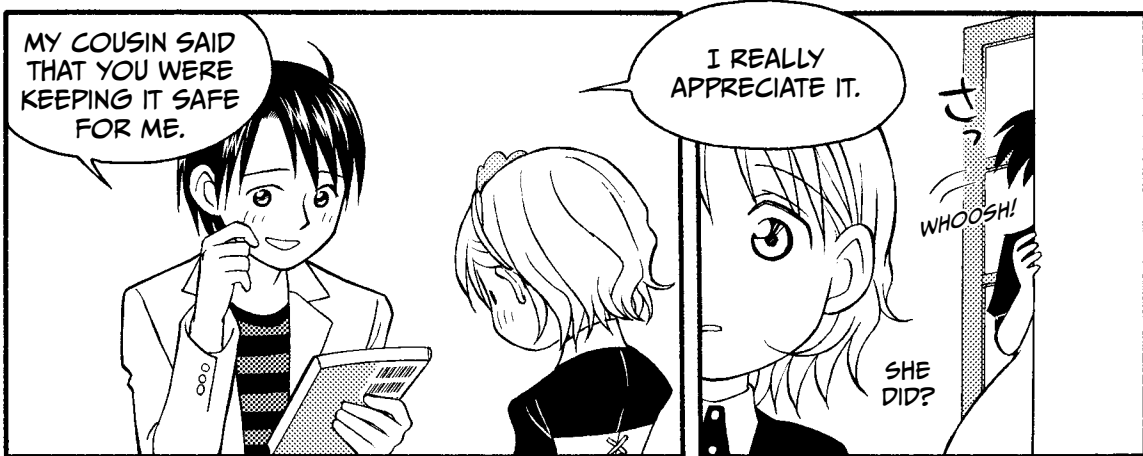
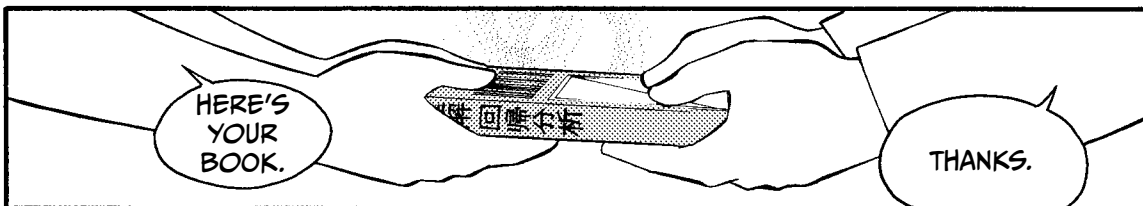
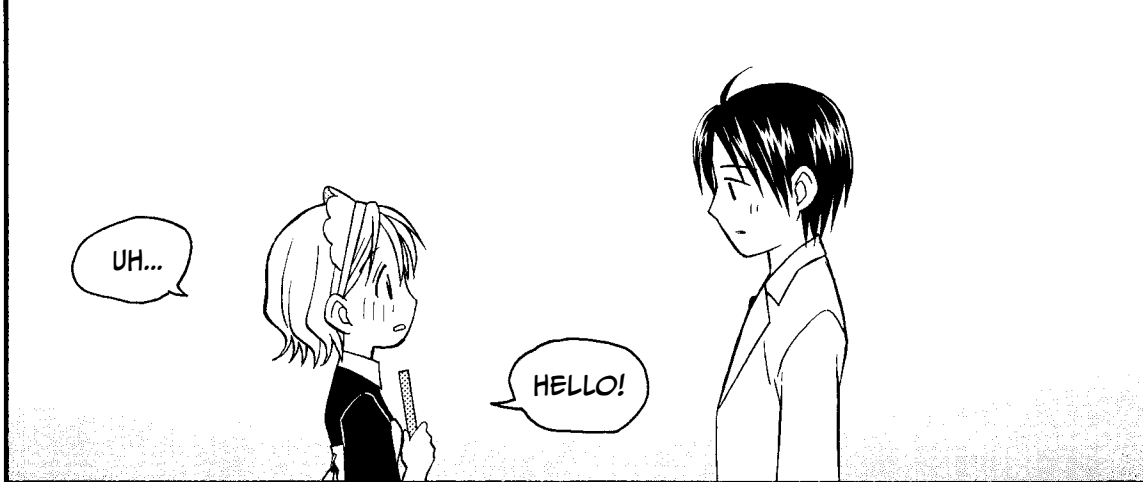

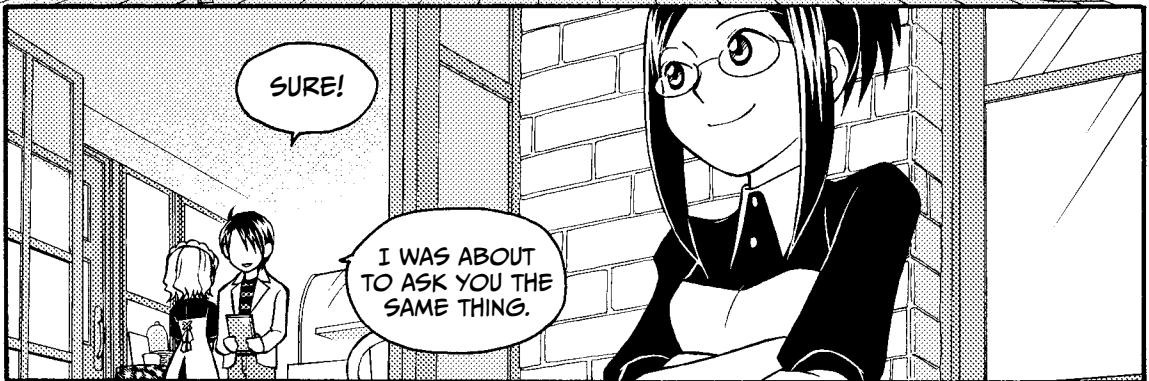
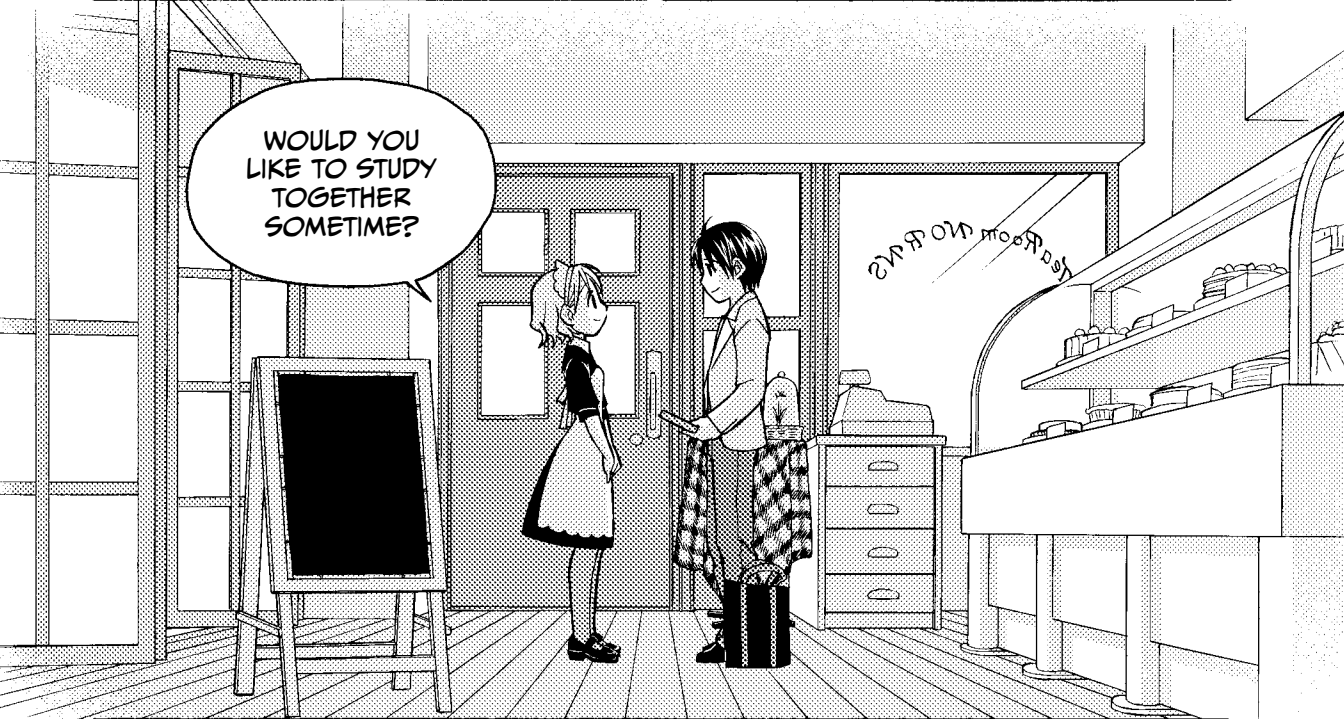
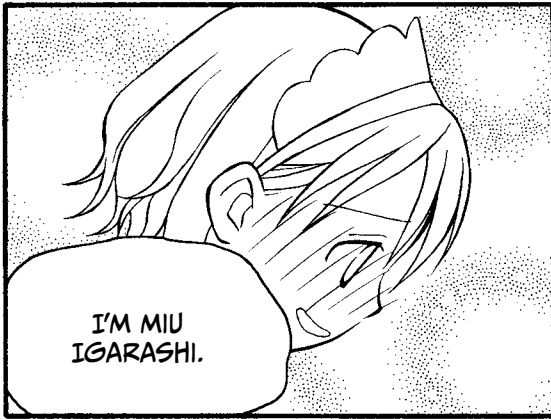

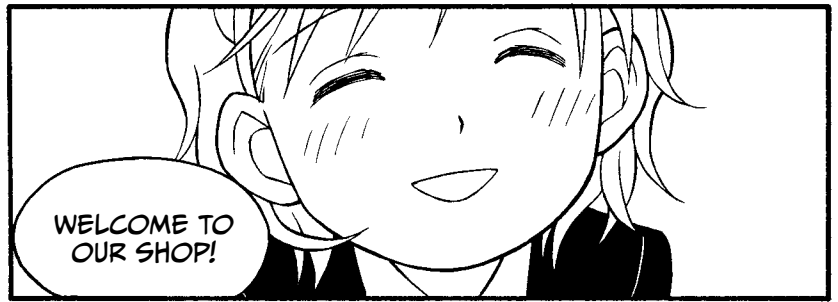
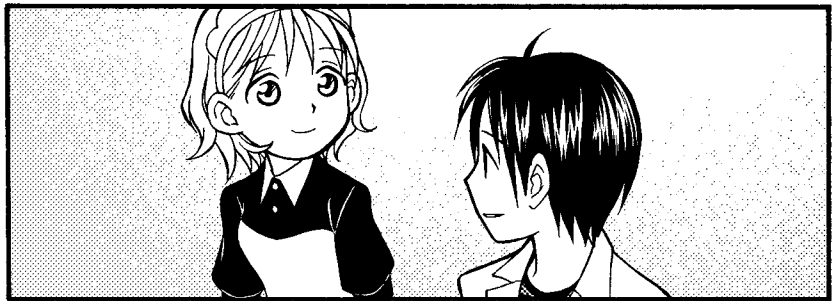
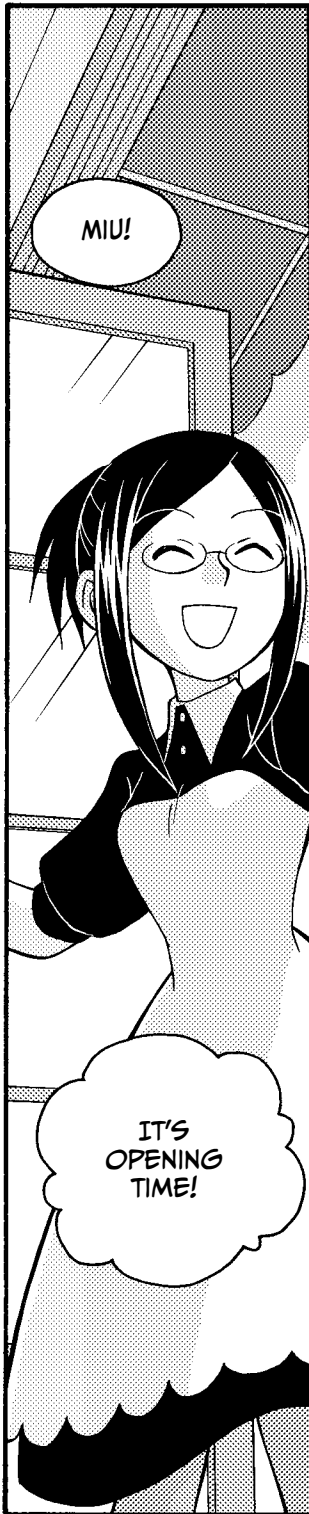

LOGISTIC REGRESSION ANALYSIS IN THE REAL WORLD

On page 68, Risa made a list of all the steps of regression analysis, but later it was noted that it's not always necessary to perform each of the steps. For example, if we're analyzing Miu's height over time, there's just one Miu, and she was just one height at a given age. There's no population of Miu heights at age 6, so analyzing the "population" wouldn't make sense.

In the real world too, it's not uncommon to skip Step 1, drawing the scatter plots—especially when there are thousands of data points to consider. For example, in a clinical trial with many participants, researchers may choose to start at Step 2 to save time, especially if they have software that can do the calculations quickly for them.

Furthermore, when you do statistics in the real world, don't just dive in and apply tests. Think about your data and the purpose of the test. Without context, the numbers are just numbers and signify nothing.

LOGIT, ODDS RATIO, AND RELATIVE RISK

Odds are a measure that suggests how closely a predictor and an outcome are associated. They are defined as the ratio of the probability of an outcome happening in a given situation (y) to the probability of the outcome not happening ($1 - y$):

$$\frac{y}{1 - y}$$

LOGIT

The *logit* is the log of the odds. The logistic function is its inverse, taking a log-odds and turning it into a probability. The logit is mathematically related to the regression coefficients: for every unit of increase in the predictor, the logit of the outcome increases by the value of the regression coefficient.

The equation for the logistic function, which you saw earlier when we calculated that logistic regression equation on page 170, is as follows:

$$y = \frac{1}{1 + e^{-z}}$$

where z is the logit and y is the probability.

To find the logit, we invert the logistic equation like this:

$$\log \frac{y}{1-y} = z.$$

This inverse function gives the logit based on the original logistic regression equation. The process of finding the logit is like finding any other mathematical inverse:

$$y = \frac{1}{1+e^{-z}} = \frac{1}{1+e^{-z}} \times \frac{e^z}{e^z} = \frac{e^z}{e^z+1}$$

$$y \times (e^z + 1) = \frac{e^z}{e^z+1} \times (e^z + 1) \quad \leftarrow \text{MULTIPLY BOTH SIDE OF THE EQUATION BY } (e^z + 1).$$

$$y \times e^z + y = e^z$$

$$y = e^z - y \times e^z \quad \leftarrow \text{TRANSPOSE TERMS.}$$

$$y = (1 - y) e^z$$

$$y \times \frac{1}{1-y} = (1 - y) e^z \times \frac{1}{1-y} \quad \leftarrow \text{MULTIPLY BOTH SIDE OF THE EQUATION BY } \frac{1}{1-y}.$$

$$\frac{y}{1-y} = e^z$$

$$\log \frac{y}{1-y} = \log e^z = z$$

Therefore, the logistic regression equation for selling the Norns Special (obtained on page 172),

$$y = \frac{1}{1 + e^{-(2.44x_1 + 0.54x_2 - 15.20)}}$$

can be rewritten as

$$\log \frac{y}{1-y} = 2.44x_1 + 0.54x_2 - 15.20.$$

So the odds of selling the Norns Special on a given day, at a given temperature are $e^{2.44x_1 + 0.54x_2 - 15.20}$, and the logit is $2.44x_1 + 0.54x_2 - 15.20$.

ODDS RATIO

Another way to quantify the association between a predictor and an outcome is the *odds ratio (OR)*. The odds ratio compares two sets of odds for different conditions of the same variable.

Let's calculate the odds ratio for selling the Norns Special on Wednesday, Saturday, or Sunday versus other days of the week:

$$\frac{\left(\frac{\text{sales rate of Wed, Sat, or Sun}}{1 - \text{sales rate of Wed, Sat, or Sun}} \right)}{\left(\frac{\text{sales rate of days other than Wed, Sat, or Sun}}{1 - \text{sales rate of days other than Wed, Sat, or Sun}} \right)} = \frac{\left[\frac{(6/9)}{1 - (6/9)} \right]}{\left[\frac{(2/12)}{1 - (2/12)} \right]} = \frac{\left[\frac{(6/9)}{(3/9)} \right]}{\left[\frac{(2/12)}{(10/12)} \right]} =$$

$$\frac{(6/3)}{(2/10)} = \frac{6}{3} \div \frac{2}{10} = \frac{6}{3} \times \frac{10}{2} = 2 \times 5 = 10$$

This shows that the odds of selling the Norns special on one of those three days are 10 times higher than on the other days of the week.

ADJUSTED ODDS RATIO

So far, we've used only the odds based on the day of the week. If we want to find the truest representation of the odds ratio, we would need to calculate the odds ratio of each variable in turn and then combine the ratios. This is called the *adjusted odds ratio*. For the data collected by Risa on page 176, this means finding the odds ratio for two variables—day of the week and temperature—at the same time.

Table 4-1 shows the logistic regression equations and odds when considering each variable separately and when considering them together, which we'll need to calculate the adjusted odds ratios.

TABLE 4-1: THE LOGISTIC REGRESSION EQUATIONS AND ODDS FOR THE DATA ON PAGE 176

Predictor variable	Logistic regression equation	Odds
"Wed, Sat, or Sun" only	$y = \frac{1}{1 + e^{-(2.30x_1 - 1.61)}}$	$e^{(2.30x_1 - 1.61)}$
"High temperature" only	$y = \frac{1}{1 + e^{-(0.52x_2 - 13.44)}}$	$e^{(0.52x_2 - 13.44)}$
"Wed, Sat, or Sun" and "High temperature"	$y = \frac{1}{1 + e^{-(2.44x_1 + 0.54x_2 - 15.20)}}$	$e^{(2.44x_1 + 0.54x_2 - 15.20)}$

The odds of a sale based only on the day of the week are calculated as follows:

$$\frac{\text{odds of a sale on Wed, Sat, or Sun}}{\text{odds of a sale on days other than Wed, Sat, or Sun}} = \frac{e^{2.30 \times 1 - 1.61}}{e^{2.30 \times 0 - 1.61}} =$$

$$e^{2.30 \times 1 - 1.61 - (2.30 \times 0 - 1.61)} = e^{2.30}$$

This is the unadjusted odds ratio for “Wednesday, Saturday, or Sunday.” If we evaluate that, we get $e^{2.30} = 10$, the same value we got for the odds ratio on page 192, as you would expect!

To find the odds of a sale based only on temperature, we look at the effect a change in temperature has. We therefore find the odds of making a sale with a temperature difference of 1 degree calculated as follows:

$$\frac{\text{odds of a sale with high temp of } (k + 1) \text{ degrees}}{\text{odds of a sale with high temp of } k \text{ degrees}} = \frac{e^{0.52 \times (k+1) - 13.44}}{e^{0.52 \times k - 13.44}} =$$

$$e^{0.52 \times (k+1) - 13.44 - (0.52 \times k - 13.44)} = e^{0.52}$$

This is the unadjusted odds ratio for a one degree increase in temperature.

However, the logistic regression equation that was calculated from this data considered both of these variables together, so the regression coefficients (and thus the odds ratios) have to be adjusted to account for multiple variables.

In this case, when the regression equation is calculated using both day of the week and temperature, we see that both exponents and the constant have changed. For day of the week, the coefficient has increased from 2.30 to 2.44, temperature increased from 0.52 to 0.54, and the constant is now -15.20 . These changes are due to *interactions* between variables—when changes in one variable alter the effects of another variable, for example if the day being a Saturday changes the effect that a rise in temperature has on sales. With these new numbers, the same calculations are performed, first varying the day of the week:

$$\frac{e^{2.44 \times 1 + 0.54 \times k - 15.20}}{e^{2.44 \times 0 + 0.54 \times k - 15.20}} = e^{2.44 \times 1 + 0.54 \times k - 15.20 - (2.44 \times 0 + 0.54 \times k - 15.20)} = e^{2.44}$$

This is the adjusted odds ratio for “Wednesday, Saturday, or Sunday.” In other words, the day-of-the-week odds have been adjusted to account for any combined effects that may be seen when temperature is also considered.

Likewise, after adjusting the coefficients, the odds ratio for temperature can be recalculated:

$$\frac{e^{2.44 \times 1 + 0.54 \times (k+1) - 15.20}}{e^{2.44 \times 1 + 0.54 \times k - 15.20}} = \frac{e^{2.44 \times 0 + 0.54 \times (k+1) - 15.20}}{e^{2.44 \times 0 + 0.54 \times k - 15.20}} = e^{0.54 \times (k+1) - 15.20 - (0.54 \times k - 15.20)} = e^{0.54}$$

This is the adjusted odds ratio for “high temperature.” In this case, the temperature odds ratio has been adjusted to account for possible effects of the day of the week.

HYPOTHESIS TESTING WITH ODDS

As you’ll remember, in linear regression analysis, we perform a hypothesis test by asking whether A is equal to zero, like this:

Null hypothesis	$A_i = 0$
Alternative hypothesis	$A_i \neq 0$

In logistic regression analysis, we perform a hypothesis test by evaluating whether coefficient A as a power of e equals e^0 :

Null hypothesis	$e^{A_i} = e^0 = 1$
Alternative hypothesis	$e^{A_i} \neq e^0 = 1$

Remember from Table 4-1 that $e^{(2.30x_1 - 1.61)}$ is the odds of selling the Norns Special based on the day of the week. If, instead, the odds were found to be $e^{0x_1 - 1.61}$, it would mean the odds of selling the special were the same every day of the week. Therefore, the null hypothesis would be true: day of the week has no effect on sales. Checking whether $A_i = 0$ and whether $e^{A_i} = e^0 = 1$ are effectively the same thing, but because logistic regression analysis is about odds and probabilities, it is more relevant to write the hypothesis test in terms of odds.

CONFIDENCE INTERVAL FOR AN ODDS RATIO

Odds ratios are often used in clinical studies, and they’re generally presented with a confidence interval. For example, if medical researchers were trying to determine whether ginger helps to alleviate an upset stomach, they might separate people with stomach ailments into two groups and then give one group ginger pills and the other a placebo. The scientists would then measure the discomfort of the people after taking the pills and calculate an odds

ratio. If the odds ratio showed that people given ginger felt better than people given a placebo, the researchers could use a confidence interval to get a sense of the standard error and the accuracy of the result.

We can also calculate a confidence interval for the Norns Special data. Below, we calculate the interval with a 95% confidence rate.

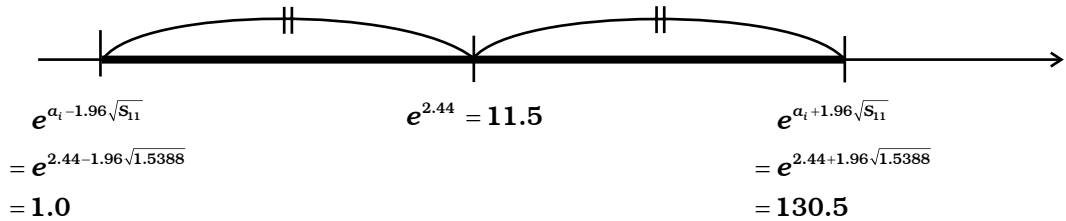

If we look at a population of all days that a Norns Special was on sale, we can be sure the odds ratio is somewhere between 1 and 130.5. In other words, at worst, there is no difference in sales based on day of the week (when the odds ratio = 1), and at best, there is a very large difference based on the day of the week. If we chose a confidence rate of 99%, we would change the 1.96 above to 2.58, which makes the interval 0.5 to 281.6. As you can see, a higher confidence rate leads to a larger interval.

RELATIVE RISK

The *relative risk (RR)*, another type of ratio, compares the probability of an event occurring in a group exposed to a particular factor to the probability of the same event occurring in a nonexposed group. This ratio is often used in statistics when a researcher wants to compare two outcomes and the outcome of interest is relatively rare. For example, it's often used to study factors associated with contracting a disease or the side effects of a medication.

You can also use relative risk to study something less serious (and less rare), namely whether day of the week increases the chances that the Norns Special will sell. We'll use the data from page 166.

First, we make a table like Table 4-2 with the condition on one side and the outcome on the other. In this case, the condition is the day of the week. The condition must be binary (yes or no), so since Risa thinks the Norns special sells best on Wednesday, Saturday, and Sunday, we consider the condition present on one of those three days and absent on any other day. As for the outcome, either the cake sold or it didn't.

TABLE 4-2: CROSS-TABULATION TABLE OF "WEDNESDAY, SATURDAY, OR SUNDAY" AND "SALES OF NORNS SPECIAL"

		Sales of Norns Special		Sum
		Yes	No	
Wed, Sat, or Sun	Yes	6	3	9
	No	2	10	12
Sum		8	13	21

To find the relative risk, we need to find the ratio of Norns Specials sold on Wednesday, Saturday, or Sunday to the total number offered for sale on those days. In our sample data, the number sold was 6, and the number offered for sale was 9 (3 were not sold). Thus, the ratio is 6:9.

Next, we need the ratio of the number sold on any other day to the total number offered for sale on any other day. This ratio is 2:12.

Finally, we divide these ratios to find the relative risk:

$$\frac{\text{sales rate of Wed, Sat, or Sun}}{\text{the sales rate of days other than Wed, Sat, or Sun}} = \frac{(6/9)}{(2/12)} = \frac{6}{9} \div \frac{2}{12} = \frac{6}{9} \times \frac{12}{2} = \frac{2}{3} \times 6 = 4$$

So the Norns Special is 4 times more likely to sell on Wednesday, Saturday or Sunday. It looks like Risa was right!

It's important to note that often researchers will report the odds ratio in lieu of the relative risk because the odds ratio is more closely associated with the results of logistic regression analysis and because sometimes you aren't able to calculate the relative risk; for example, if you didn't have complete data for sales rates on all days other than Wednesday, Saturday, and Sunday. However, relative risk is more useful in some situations and is often easier to understand because it deals with probabilities and not odds.

APPENDIX
REGRESSION CALCULATIONS
WITH EXCEL

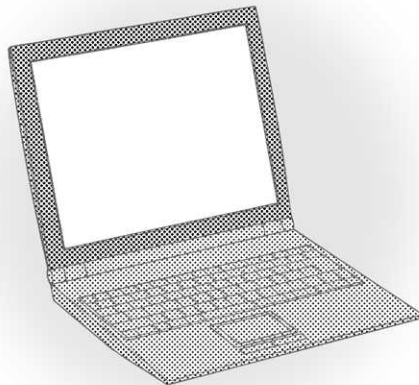

This appendix will show you how to use Excel functions to calculate the following:

- Euler's number (e)
- Powers
- Natural logarithms
- Matrix multiplication
- Matrix inverses
- Chi-squared statistic from a p -value
- p -value from a chi-squared statistic
- F statistic from a p -value
- p -value from an F statistic
- Partial regression coefficient of a multiple regression analysis
- Regression coefficient of a logistic regression equation

We'll use a spreadsheet that already includes the data for the examples in this appendix. Download the Excel spreadsheet from <http://www.nostarch.com/regression/>.

EULER'S NUMBER

Euler's number (e), introduced on page 19, is the base number of the natural logarithm. This function will allow you to raise Euler's number to a power. In this example, we'll calculate e^1 .

1. Go to the *Euler's Number* sheet in the spreadsheet.
2. Select cell **B1**.

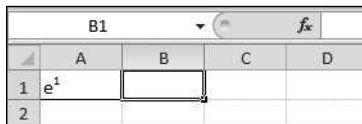

	A	B	C	D
1	e^1			
2				

3. Click **Formulas** in the top menu bar and select **Insert Function**.

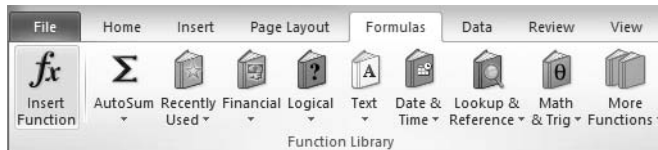

4. From the category drop-down menu, select **Math & Trig**. Select the **EXP** function and then click **OK**.

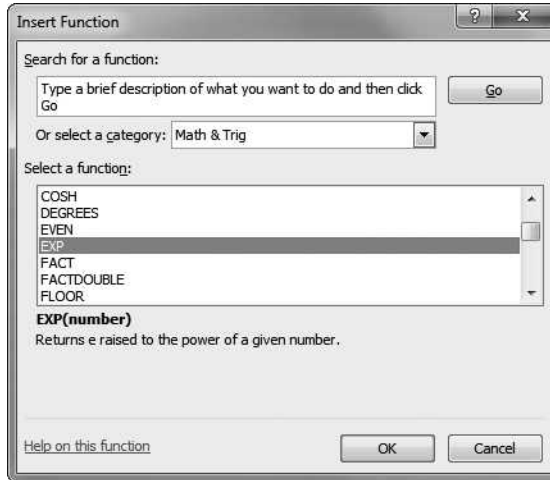

5. You'll now see a dialog where you can enter the power to which you want to raise e . Enter **1** and then click **OK**.

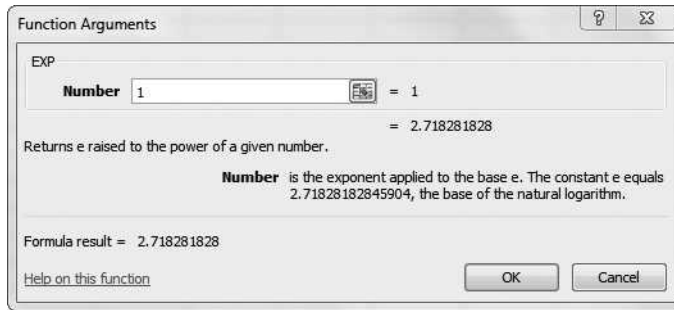

Because we've calculated Euler's number to the power of 1, you'll just get the value of e (to a few decimal places), but you can raise e to any power using the EXP function.

	A	B	C	D	E
1	e^1	2.718282			
2					

NOTE You can avoid using the Insert Function menu by entering $=EXP(X)$ into the cell. For example, entering $=EXP(1)$ will also give you the value of e . This is the case for any function: after using the Insert Function menu, simply look at the formula bar for the function you can enter directly into the cell.

POWERS

This function can be used to raise any number to any power. We'll use the example question from page 14: "What's 2 cubed?"

1. Go to the *Power* sheet in the spreadsheet.
2. Select cell **B1** and type **=2^3**. Press **ENTER**.

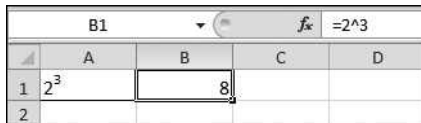

The screenshot shows a portion of an Excel spreadsheet. The formula bar at the top displays the formula $=2^3$. The spreadsheet grid shows columns A, B, C, and D, and rows 1 and 2. Cell A1 contains the text 2^3 . Cell B1 contains the numerical result 8. Cells C1 and D1 are empty. Row 2 is also empty.

In Excel, we use the \wedge symbol to mean "to the power of," so 2^3 is 2^3 , and the result is 8. Make sure to include the equal sign (=) at the start or Excel will not calculate the answer for you.

NATURAL LOGARITHMS

This function will perform a natural log transformation (see page 20).

1. Go to the *Natural Log* sheet in the spreadsheet.
2. Select cell **B1**. Click **Formulas** in the top menu bar and select **Insert Function**.
3. From the category drop-down menu, select **Math & Trig**. Select the **LN** function and then click **OK**.

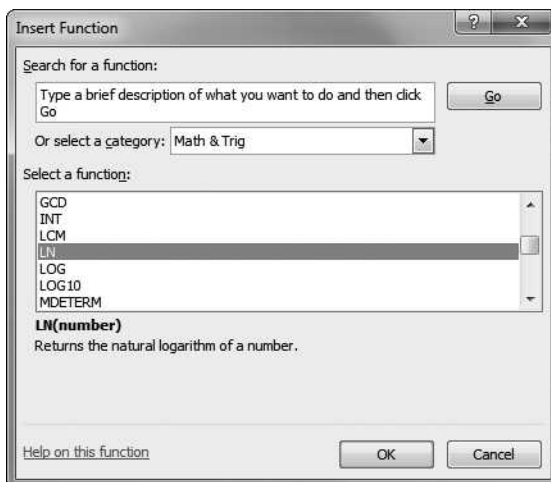

4. Enter **exp(3)** and click **OK**.

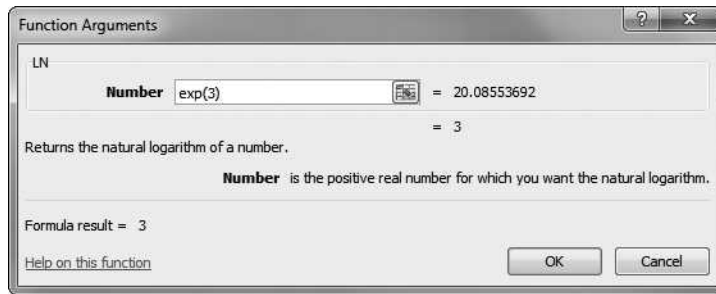

You should get the natural logarithm of e^3 , which, according to Rule 3 on page 22, will of course be 3. You can enter any number here, with a base of e or not, to find its natural log. For example, entering $\text{exp}(2)$ would produce 2, while entering just 2 would give 0.6931.

MATRIX MULTIPLICATION

This function is used to multiply matrices—we'll calculate the multiplication example shown in Example Problem 1 on page 41.

1. Go to the *Matrix Multiplication* sheet in the spreadsheet.
2. Select cell **G1**. Click **Formulas** in the top menu bar and select **Insert Function**.
3. From the category drop-down menu, select **Math & Trig**. Select the **MMULT** function and then click **OK**.

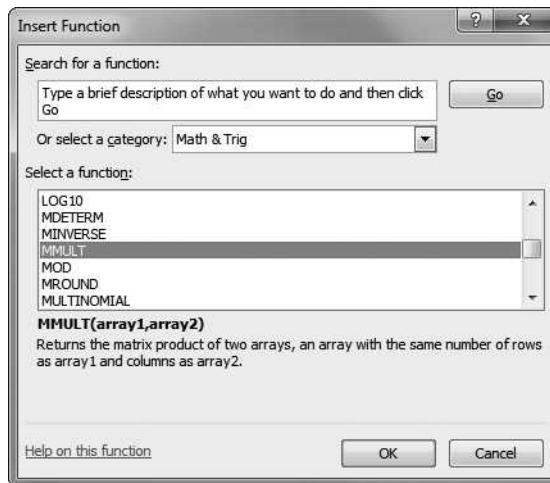

- Click in the **Array1** field and highlight all the cells of the first matrix in the spreadsheet. Then click in the **Array2** field and highlight the cells containing the second matrix. Click **OK**.

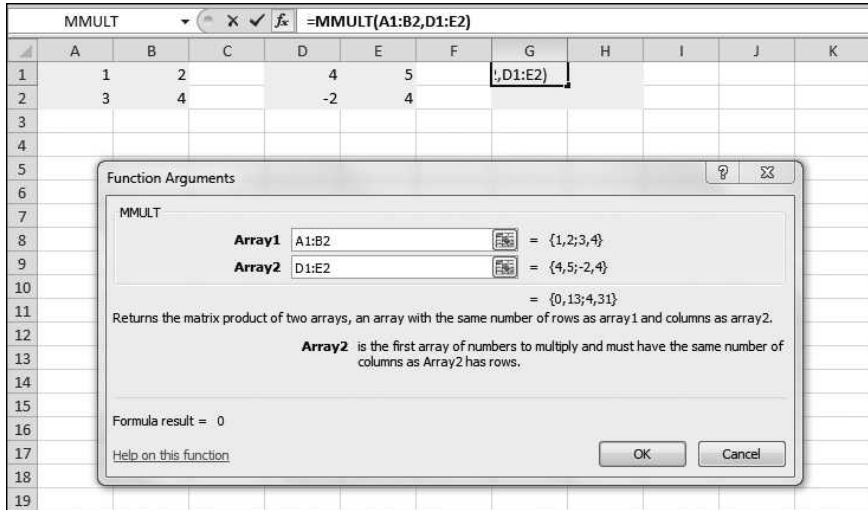

- Starting with **G1**, highlight a matrix of cells with the same dimensions as the matrices you are multiplying—G1 to H2 in this example. Then click in the formula bar.

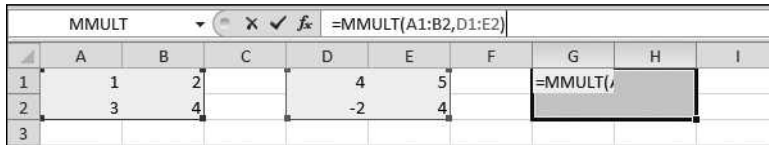

- Press **CTRL-SHIFT-ENTER**. The fields in your matrix should fill with the correct values.

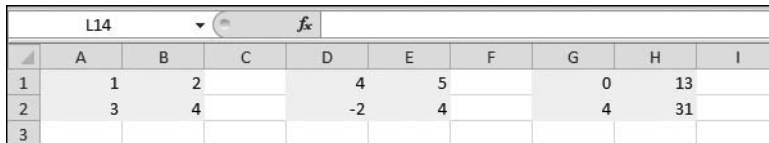

You should get the same results as Risa gets at the bottom of page 41. You can do this with any matrices that share the same dimensions.

MATRIX INVERSION

This function calculates matrix inverses—we'll use the example shown on page 44.

1. Go to the *Matrix Inversion* sheet in the spreadsheet.
2. Select cell **D1**. Click **Formulas** in the top menu bar and select **Insert Function**.
3. From the category drop-down menu, select **Math & Trig**. Select the **MINVERSE** function and then click **OK**.

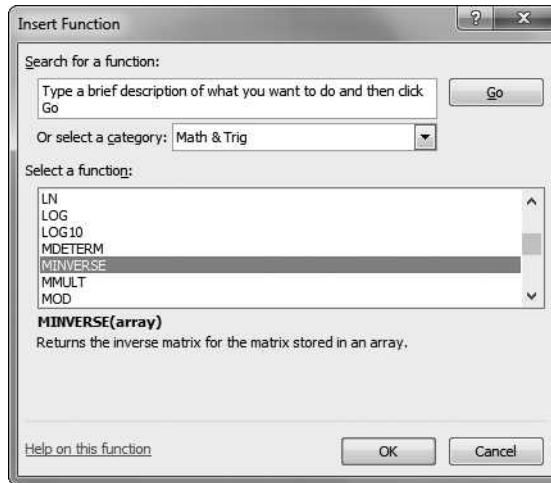

4. Select and highlight the matrix in the sheet—that's cells **A1** to **B2**—and click **OK**.

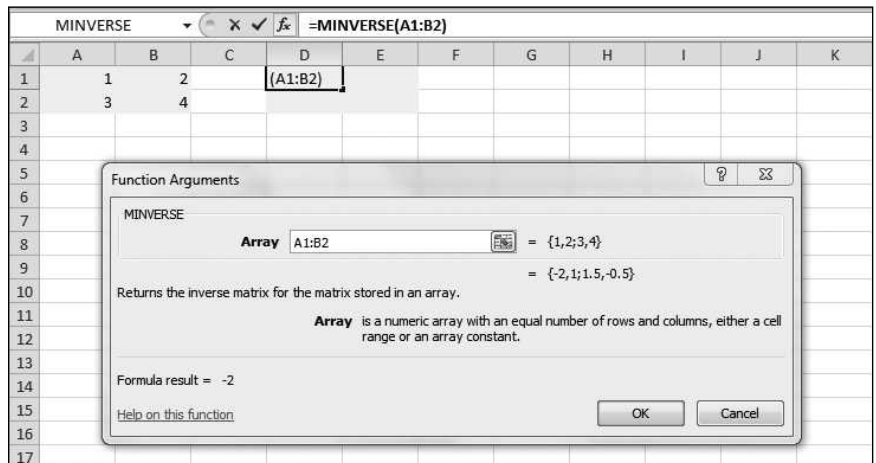

5. Starting with **D1**, select and highlight a matrix of cells with the same dimensions as the first matrix—in this case, **D1** to **E2**. Then click in the formula bar.

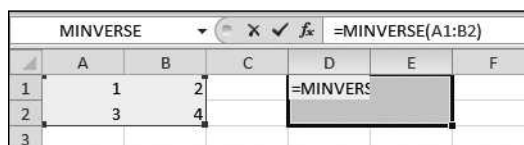

6. Press CTRL-SHIFT-ENTER. The fields in your matrix should fill with the correct values.

	A	B	C	D	E	F
1	1	2		-2	1	
2	3	4		1.5	-0.5	
3						

You should get the same result as Risa does on page 44. You can use this on any matrix you want to invert; just make sure the matrix of cells you choose for the results has the same dimensions as the matrix you're inverting.

CALCULATING A CHI-SQUARED STATISTIC FROM A P-VALUE

This function calculates a test statistic from a chi-squared distribution, as discussed on page 54. We'll use a *p*-value of .05 and 2 degrees of freedom.

1. Go to the *Chi-Squared from p-Value* sheet in the spreadsheet.
2. Select cell **B3**. Click **Formulas** in the top menu bar and then select **Insert Function**.
3. From the category drop-down menu, select **Statistical**. Select the **CHISQ.INV.RT** function and then click **OK**.

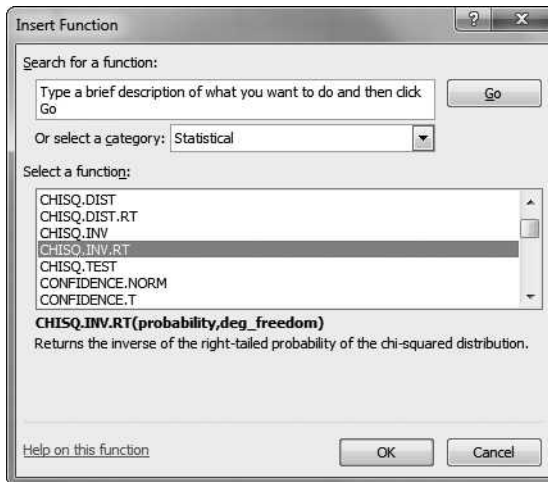

4. Click in the **Probability** field and enter **B1** to select the probability value in that cell. Then click in the **Deg_freedom** field and enter **B2** to select the degrees of freedom value. When (B1,B2) appears in cell B3, click **OK**.

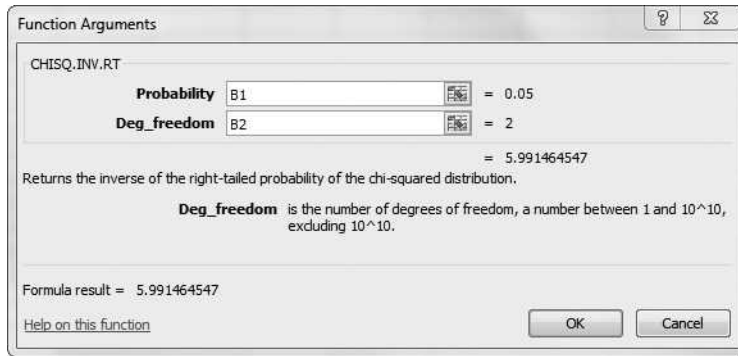

You can check this calculation against Table 1-6 on page 56.

CALCULATING A P-VALUE FROM A CHI-SQUARED STATISTIC

This function is used on page 179 in the likelihood ratio test to obtain a *p*-value. We're using a test statistic value of 10.1 and 2 degrees of freedom.

1. Go to the *p-Value from Chi-Squared* sheet in the spreadsheet.
2. Select cell **B3**. Click **Formulas** in the top menu bar and select **Insert Function**.
3. From the category drop-down menu, select **Statistical**. Select the **CHISQ.DIST.RT** function and then click **OK**.

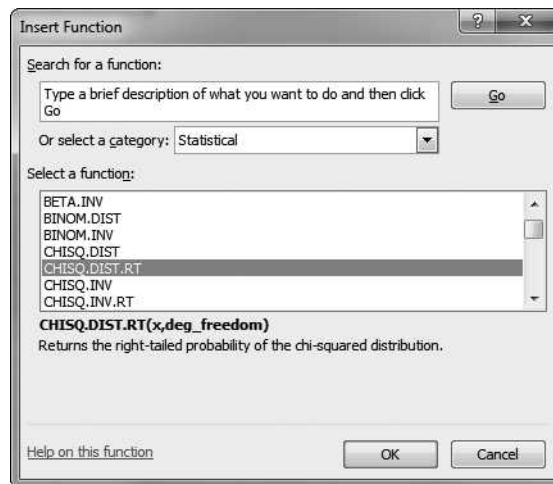

- Click in the **X** field and enter **B1** to select the chi-squared value in that cell. Then click the **Deg_freedom** field and enter **B2** to select the degrees of freedom value. When (B1,B2) appears in cell B3, click **OK**.

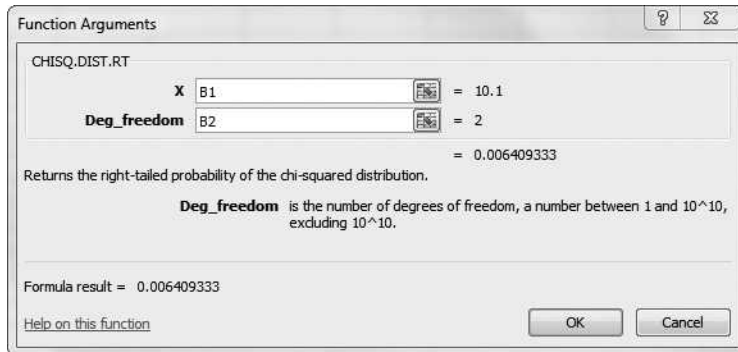

We get 0.006409, which on page 179 has been rounded down to 0.006.

	B3		f_x	=CHISQ.DIST.RT(B1,B2)	
	A	B	C	D	E
1	Chi-squared	10.1			
2	Freedom	2			
3	Probability	0.006409			
4					

CALCULATING AN F STATISTIC FROM A P-VALUE

This function gives us the F statistic we calculated on page 58.

- Go to the *F Statistic from p-Value* sheet in the spreadsheet.
- Select cell **B4**. Click **Formulas** in the top menu bar and select **Insert Function**.
- From the category drop-down menu, select **Statistical**. Select the **F.INV.RT** function and then click **OK**.

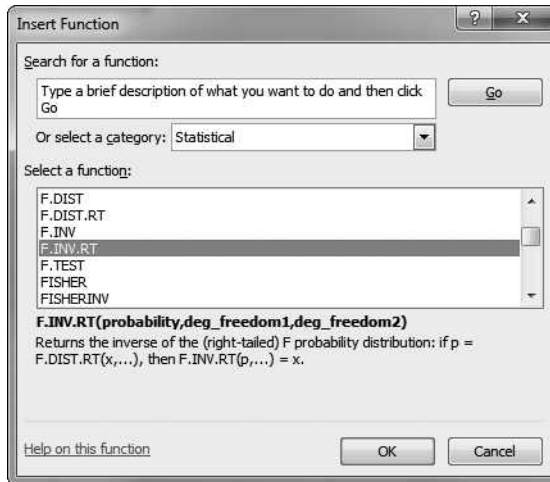

4. Click in the **Probability** field and enter **B1** to select the probability value in that cell. Click in the **Deg_freedom1** field and enter **B2** and then select the **Deg_freedom2** field and enter **B3**. When (B1,B2,B3) appears in cell B3, click **OK**.

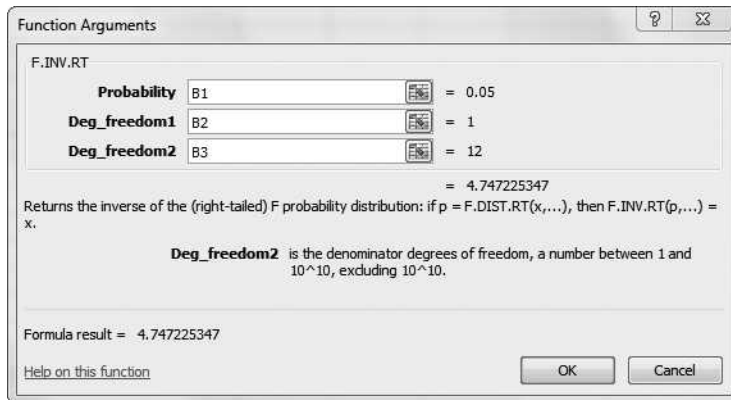

We get 4.747225, which has been rounded down to 4.7 in Table 1-7 on page 58.

	B4	f_x	=F.INV.RT(B1,B2,B3)	
	A	B	C	D
1	Probability	0.05		
2	1 degree of freedom	1		
3	2 degrees of freedom	12		
4	F	4.747225		
5				

CALCULATING A P-VALUE FROM AN F STATISTIC

This function is used on page 90 to calculate the p -value in an ANOVA.

1. Go to the *p-Value for F Statistic* sheet in the spreadsheet.
2. Select cell **B4**. Click **Formulas** in the top menu bar and select **Insert Function**.
3. From the category drop-down menu, select **Statistical**. Select the **F.DIST.RT** function and then click **OK**.

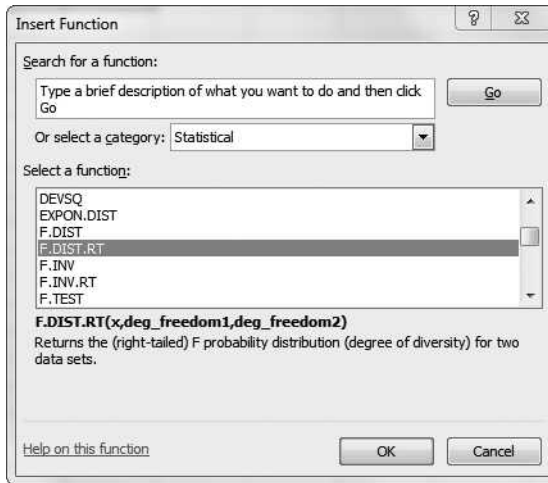

4. Click in the **X** field and enter **B1** to select the F value in that cell. Click in the **Deg_freedom1** field and enter **B2**, and then click in the **Deg_freedom2** field and enter **B3**. When (B1,B2,B3) appears in cell B3, click **OK**.

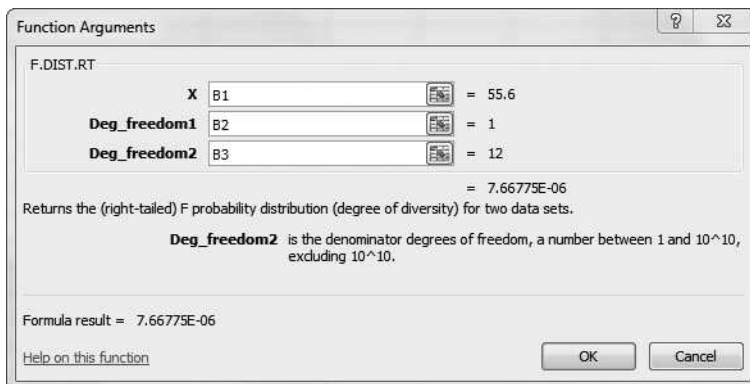

The result, 7.66775E-06, is the way Excel presents the value 7.66775×10^{-6} . If we were testing at the $p = .05$ level, this would be a significant result because it is less than .05.

B4		fx =F.DIST.RT(B1,B2,B3)		
	A	B	C	D
1	F	55.6		
2	1 degree of freedom	1		
3	2 degrees of freedom	12		
4	Probability	7.66775E-06		
5				

PARTIAL REGRESSION COEFFICIENT OF A MULTIPLE REGRESSION ANALYSIS

This function calculates the partial regression coefficients for the data on page 113, giving the results that Risa gets on page 118.

1. Go to the *Partial Regression Coefficient* sheet in the spreadsheet.
2. Select cell G2. Click **Formulas** in the top menu bar and select **Insert Function**.
3. From the category drop-down menu, select **Statistical**. Select the **LINEST** function and then click **OK**.

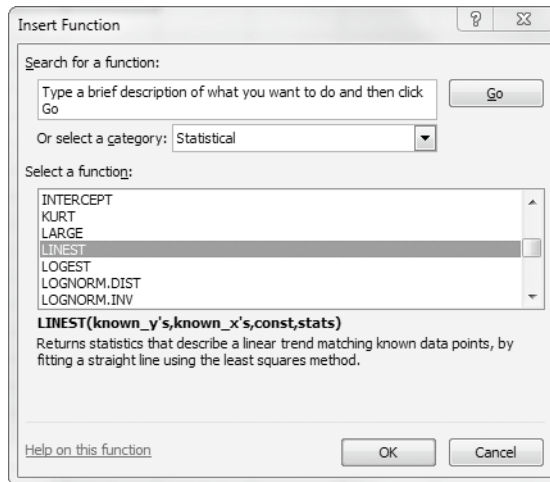

- Click in the **Known_y's** field and highlight the data cells for your outcome variable—here it's D2 to D11. Click in the **Known_x's** field and highlight the data cells for your predictor variables—here B2 to C11. You don't need any values for Const and Stats, so click **OK**.

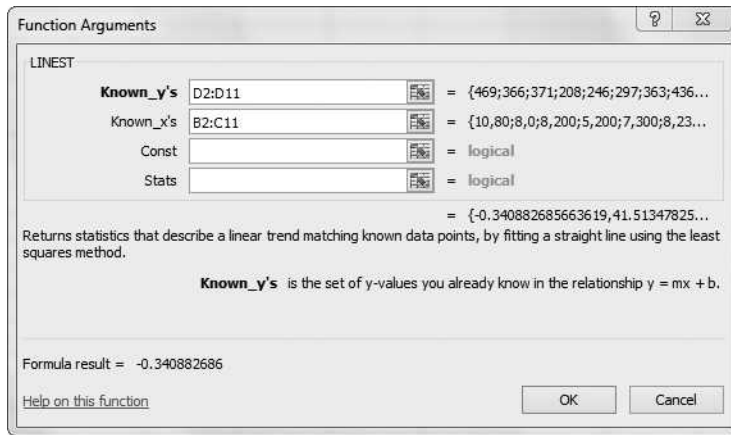

- The full function gives you three values, so highlight G1 to I1 and click the function bar. Press CTRL-SHIFT-ENTER, and the highlighted fields should fill with the correct values.

G2		={=LINEST(D2:D11,B2:C11)}									
	A	B	C	D	E	F	G	H	I	J	
		Floor space (tsubo)	Distance to nearest station (meters)	Monthly sales			Distance to nearest station (meters)	Floor space (tsubo)	Constant term		
1											
2	Yumenooka Shop	10	80	469		Partial regression coefficient	-0.3409	41.5135	65.3239		
3	Terai Station Shop	8	0	366							
4	Sone Shop	8	200	371							
5	Hashimoto Station Shop	5	200	208							
6	Kikyuu Town Shop	7	300	246							
7	Post Office Shop	8	230	297							
8	Suidobashi Station Shop	7	40	363							
9	Rokujo Station Shop	9	0	436							
10	Wakaba Riverside Shop	6	330	198							
11	Misato Shop	9	180	364							
12											

You can see that the results are the same as Risa's results on page 118 (in the text, they have been rounded).

REGRESSION COEFFICIENT OF A LOGISTIC REGRESSION EQUATION

There is no Excel function that calculates the logistic regression coefficient, but you can use Excel's Solver tool. This example calculates the maximum likelihood coefficients for the logistic regression equation using the data on page 166.

1. Go to the *Logistic Regression Coefficient* sheet in the spreadsheet.
2. First you'll need to check whether Excel has Solver loaded. When you select **Data** in the top menu bar, you should see a button to the far right named *Solver*. If it is there, skip ahead to Step 4; otherwise, continue on to Step 3.

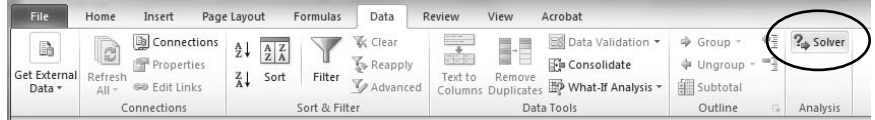

3. If the Solver button isn't there, go to **File** ▶ **Options** ▶ **Add-Ins** and select the **Solver Add-in**. Click **Go**, select **Solver Add-in** in the Add-Ins dialog, and then click **OK**. Now when you select **Data** in the top menu bar, the Solver button should be there.

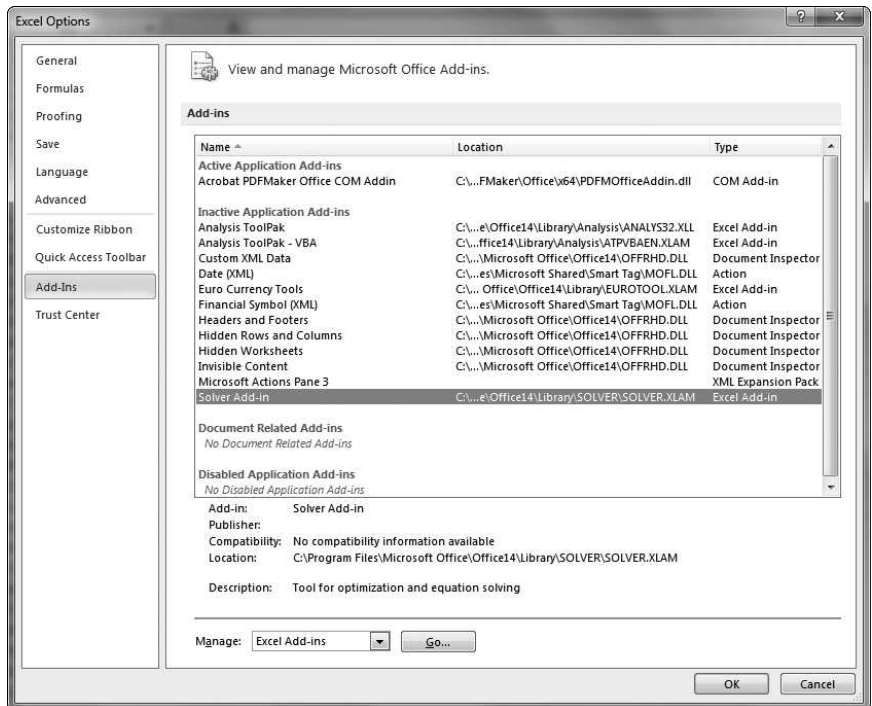

4. Click the **Solver** button. Click in the **Set Objective** field and select cell L3 to select the log likelihood data. Click in the **By Changing Variable Cells** field and select the cells where you want your results to appear—in this case L5 to L7. Click **Solve**.

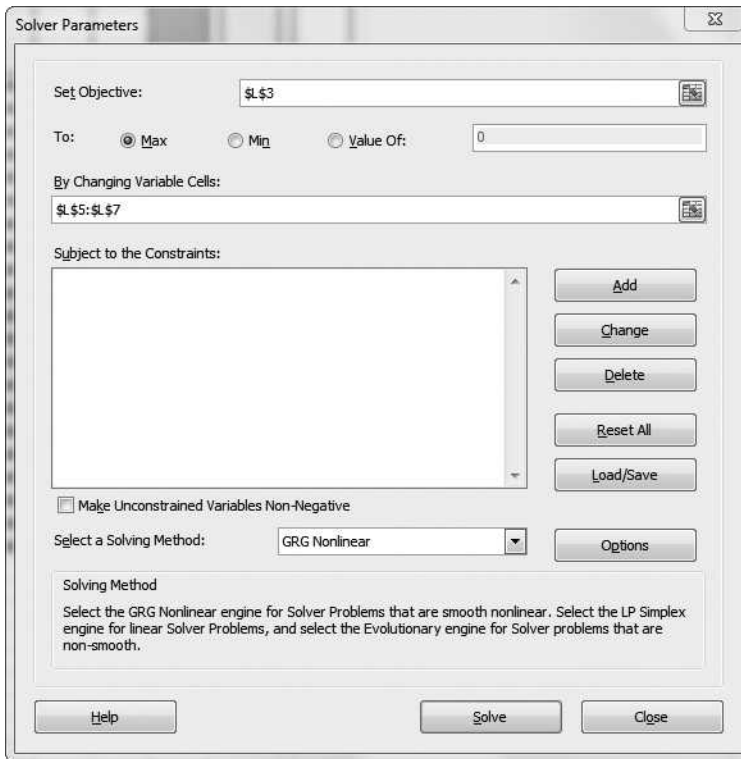

You should get the same answers as in Step 4 on page 172 (in the text, they've been rounded).

INDEX

SYMBOLS

Δ (delta), 29

' (prime), 32

A

accuracy. *See also* coefficient of determination
of logistic regression
analysis equation, 173–177
of multiple regression
equation, 119–126
adding matrices, 39–40
adjusted odds ratio,
192–194
adjusted R^2 , 124–126
alternative hypothesis
(H_a), 48
analysis of variance
(ANOVA). *See also*
hypothesis testing
logistic regression
analysis, 178–181
multiple regression
analysis, 128–132
regression analysis,
87–90
apparent error rate, 177
assumptions of normality,
85–86
autocorrelation, checking
for, 102–103
average, 72

B

bell curves, 53–54
best subsets regression,
139–140
binomial logistic regression
analysis. *See* logistic
regression analysis

C

calculus, differential. *See*
differential calculus
Canceling Exponentials
Rule, 22
categorical data, 46
converting numerical
data, 46–47
in logistic regression
analysis, 167
in multiple regression
analysis, 147–149
chi-squared (χ^2) distri-
butions, 54–55, 56,
204–206
coefficient of determi-
nation (R^2)
adjusted, 124–126
logistic regression
analysis, 173–177
multiple regression
analysis, 119–126
regression analysis,
81–82

coefficients. *See specific
coefficients by name*
columns, in matrices, 38
concentration matrix, 145
confidence coefficient,
92–93
confidence intervals,
calculating
multiple regression
analysis,
133–135, 146
for odds ratio, 194–195
regression analysis,
91–94
correlation coeffi-
cient (R), 70
general discussion,
64–65
multiple regression
analysis, 120
regression analysis,
78–82
critical value, 55

D

data. *See also*
categorical data
plotting, 64–65
types of, 46–47
degrees of freedom, 50–51
delta (Δ), 29
dependent variables, 14,
67, 149–152. *See also*
scatter plots

- differential calculus
 - differentiating, 31–36
 - general discussion, 24–30
 - Durbin-Watson statistic, 102–103

 - E**
 - elements, in matrices, 38
 - Euler's number, 19, 198–199
 - event space, 53
 - Excel functions, 198
 - Exponentiation Rule, 22
 - exponents, 19–23, 200
 - extrapolation, 102

 - F**
 - F* distributions, 57–59, 206–209
 - freedom, degrees of, 50–51
 - F*-test, 129–133
 - functions. *See also*
 - probability density functions
 - exponential, 19–23
 - inverse, 14–18
 - likelihood, 161–163, 171
 - logarithmic, 19–23
 - log-likelihood, 161–163, 171–172
 - natural logarithm, 20, 200–201

 - G**
 - graphs. *See also*
 - scatter plots
 - for inverse functions, 17–18
 - logistic regression analysis equation, 159

 - H**
 - H_0 (null hypothesis), 48
 - H_a (alternative hypothesis), 48

 - hypothesis testing, 85–90
 - logistic regression analysis, 178–181
 - multiple regression analysis, 128–132
 - with odds, 194

 - I**
 - identity matrices, 44
 - independent variables, 14, 67
 - choosing best combination of, 138–140
 - determining influence on outcome variables, 149–152
 - logistic regression analysis, 164–167
 - multicollinearity, 149
 - structural equation modeling, 152
 - interpolation, 102
 - inverse functions, 14–18
 - inverse matrices, 44, 202–204

 - L**
 - likelihood function, 161–163, 171
 - likelihood ratio test, 179
 - linear equations, turning nonlinear equations into, 104–106
 - linear least squares regression, 71–76, 115
 - linear regression analysis, 7
 - linearly independent data, 47
 - logarithms, 19–23
 - logistic regression analysis, 8, 157
 - accuracy of equation, assessing, 173–177
 - adjusted odds ratio, 192–194

 - confidence intervals
 - for odds ratios, 194–195
 - equation for, calculating, 158–159, 170–173
 - hypothesis testing, 178–181, 194
 - maximum likelihood method, 159–163, 210–212
 - odds ratio, 192–194
 - predicting with, 182
 - predictor variables, choosing, 164–167
 - procedure, general discussion of, 168, 190
 - relative risk, 195–196
 - scatter plot, drawing, 169
-
- logit, 190–191
- log-likelihood function, 161–163, 171–172
-
- M**
- Mahalanobis distance, 133, 137, 144–146
- matrices
 - adding, 39–40
 - general discussion, 37–38
 - identity, 44
 - inverse, 44, 202–204
 - multiplying, 40–43, 201–202
 - prediction intervals, calculating, 144–146
- maximum likelihood estimate, 162–163
- mean, 49
- median, 49
- multicollinearity, 149
- multiple correlation coefficient
 - accuracy of multiple regression equation, 119–121
 - adjusted, 124–126
 - problems with, 122–123

multiple regression
 analysis, 7–8, 111
 accuracy of equation,
 assessing, 119–126
 analysis of variance,
 128–132
 categorical data, using
 in, 147–149
 confidence intervals,
 calculating,
 133–135
 equation for, calculating,
 115–119
 hypothesis testing, 127
 Mahalanobis distance,
 144–146
 multicollinearity, 149
 prediction intervals,
 calculating,
 136–137
 predictor variables,
 choosing, 138–140
 predictor variables,
 determining influ-
 ence on outcome
 variables, 149–152
 procedure, general dis-
 cussion of, 112, 142
 scatter plot, drawing,
 113–114
 standardized residuals,
 143–144
 multiplying matrices,
 40–43, 201–202

N

natural logarithm function,
 20, 200–201
 nonlinear regression,
 103–106
 normal distributions, 53–54
 normality, assumptions of,
 85–86
 null hypothesis (H_0), 48
 numerical data, 46–47

O

odds, 190
 hypothesis testing, 194
 logit, 190–191
 odds ratio (OR)
 adjusted, 192–194
 confidence intervals,
 calculating,
 194–195
 general discussion,
 191–192
 outcome variables, 14, 67,
 149–152
 outliers, 101, 144
 overfitting, 149

P

partial regression
 coefficients
 calculating with Excel,
 209–210
 general discussion,
 116–118
 hypothesis testing, 127,
 129–131
 Pearson product moment
 correlation coefficient,
 79. *See also* correla-
 tion coefficient
 plotting data, 64–65
 population mean, 91
 population regression, 86
 populations

assessing, 82–84
 confidence intervals,
 calculating,
 133–135

Power Rule, 21

predictions
 logistic regression
 analysis, 182
 multiple regression
 analysis, 136–137
 regression analysis,
 95–98

predictor variables, 14, 67
 choosing best combina-
 tion of, 138–140
 determining influence on
 outcome variables,
 149–152
 logistic regression
 analysis, 164–167
 multicollinearity, 149
 structural equation
 modeling, 152
 prime ($'$), 32
 probability density
 functions
 chi-squared distribution,
 54–55, 56, 204–206
 F distributions, 57–59,
 206–209
 general discussion,
 52–53
 normal distribution,
 53–54
 tables, 55–56
 Product Rule, 23
 pseudo- R^2 , 173–177

Q

qualitative data, 46
 quantitative data, 46
 Quotient Rule, 21

R

R (correlation coeffi-
 cient), 70
 general discussion,
 64–65
 multiple regression
 analysis, 120
 regression analysis,
 78–82

R^2 (coefficient of
 determination)
 adjusted, 124–126
 logistic regression
 analysis, 173–177

- R^2 (coefficient of determination), *continued*
 multiple regression
 analysis, 119–126
 regression analysis,
 81–82
- regression analysis
 analysis of variance,
 87–90
 assumptions of
 normality, 85–86
 autocorrelation, check-
 ing for, 102–103
 confidence intervals,
 calculating, 91–94
 correlation coefficient,
 calculating, 78–82
 equation, calculating,
 71–77
 equation, general
 discussion, 66–67
 interpolation and
 extrapolation, 102
 nonlinear regression,
 103–104
 prediction intervals,
 calculating, 95–98
 procedure, general dis-
 cussion of, 68, 100
 samples and popula-
 tions, 82–84
 scatter plot, drawing,
 69–70
 standardized residual,
 100–101
- regression diagnostics,
 119–121
- regression equation
 calculating, 71–77
 general discussion,
 66–67
 linear equations, turning
 nonlinear into,
 104–106
- relative risk (RR), 195–196
- residual sum of squares,
 73–74
- residuals, 71
 standardized, 100–101,
 143–144
- round-robin method,
 139–140
- rows, in matrices, 38
- RR (relative risk), 195–196
- §
- sample regression, 86
- sample variance,
 unbiased, 50
- samples, 82–84
- scatter plots
 differential calculus, 26
 for logistic regression
 analysis, 169
 for multiple regression
 analysis, 113–114
 plotting data, 64–65
 for regression analysis,
 69–70
- SEM (structural equation
 modeling), 152
- squared deviations,
 sum of, 50
- standard deviation, 51–52
- standardized residuals,
 100–101, 143–144
- statistically significant, 58
- statistics
 data types, 46–47
 hypothesis testing, 48
 variation, measuring,
 49–52
- structural equation
 modeling (SEM), 152
- subsets regression, best,
 139–140
- sum of squared
 deviations, 50
- T
- testing hypotheses, 85–90
 logistic regression
 analysis, 178–181
 multiple regression
 analysis, 128–132
 with odds, 194
- tolerance, 149
- U
- unbiased sample
 variance, 50
- V
- variables. *See* dependent
 variables; independent
 variables; scatter plots
- variance, 50–51
- variance, analysis of
 logistic regression
 analysis, 178–180
 multiple regression
 analysis, 128–132
 regression analysis,
 87–90
- variance inflation factor
 (VIF), 149
- W
- Wald test, 180
- X
- x-bar, 72
- Y
- y-hat, 73

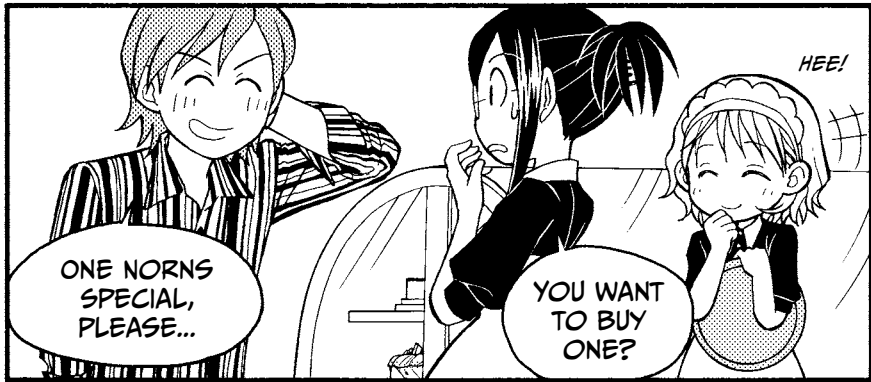

ONE NORNS
SPECIAL,
PLEASE...

YOU WANT
TO BUY
ONE?

HEE!

ABOUT THE AUTHOR

Shin Takahashi was born in 1972 in Niigata. He received a master's degree from Kyushu Institute of Design (known as Kyushu University today). Having previously worked both as an analyst and as a seminar leader, he is now an author specializing in technical literature.

Homepage: <http://www.takahashishin.jp/>

PRODUCTION TEAM FOR THE JAPANESE EDITION

SCENARIO: re_akino

ARTIST: Iroha Inoue

HOW THIS BOOK WAS MADE

The *Manga Guide* series is a co-publication of No Starch Press and Ohmsha, Ltd. of Tokyo, Japan, one of Japan's oldest and most respected scientific and technical book publishers. Each title in the best-selling *Manga Guide* series is the product of the combined work of a manga illustrator, scenario writer, and expert scientist or mathematician. Once each title is translated into English, we rewrite and edit the translation as necessary and have an expert review each volume. The result is the English version you hold in your hands.

MORE MANGA GUIDES

Find more *Manga Guides* at your favorite bookstore, and learn more about the series at <http://www.nostarch.com/manga/>.

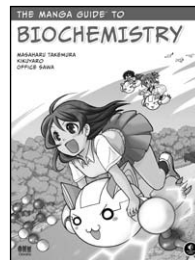
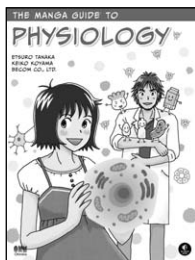
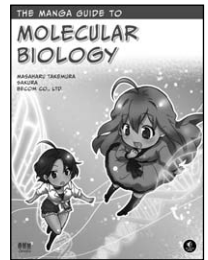
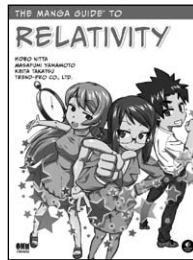
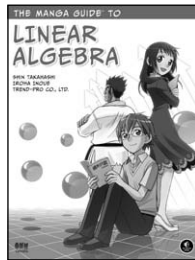
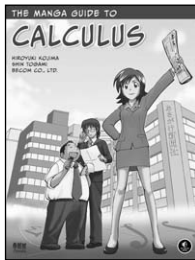
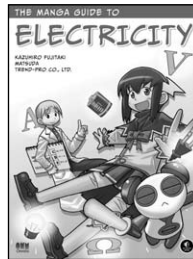
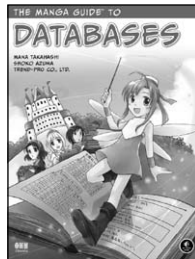

UPDATES

Visit <http://www.nostarch.com/regression/> for updates, errata, and other information.

COLOPHON

The Manga Guide to Regression Analysis is set in CCMeanwhile and Bookman. This book was printed and bound by Sheridan Books, Inc. in Chelsea, Michigan. The paper is 60# Finch Offset, which is certified by the Forest Stewardship Council (FSC).

"HIGHLY RECOMMENDED." – CHOICE MAGAZINE

"STIMULUS FOR THE NEXT GENERATION OF SCIENTISTS." – SCIENTIFIC COMPUTING

"A GREAT FIT OF FORM AND SUBJECT. RECOMMENDED." – OTAKU USA MAGAZINE



MAKE STATISTICS A CAKEWALK!

LIKE A LOT OF PEOPLE, MIU HAS HAD TROUBLE LEARNING REGRESSION ANALYSIS. BUT WITH NEW MOTIVATION—IN THE FORM OF A HANDSOME BUT SHY CUSTOMER—AND THE HELP OF HER BRILLIANT CAFÉ COWORKER RISA, SHE'S DETERMINED TO MASTER IT.

FOLLOW ALONG WITH MIU AND RISA IN *THE MANGA GUIDE TO REGRESSION ANALYSIS* AS THEY CALCULATE THE EFFECT OF TEMPERATURE ON ICED TEA ORDERS, PREDICT BAKERY REVENUES, AND WORK OUT THE PROBABILITY OF CAKE SALES WITH SIMPLE, MULTIPLE, AND LOGISTIC REGRESSION ANALYSIS. YOU'LL GET A REFRESHER IN BASIC CONCEPTS LIKE MATRIX EQUATIONS, INVERSE FUNCTIONS, LOGARITHMS, AND DIFFERENTIATION BEFORE DIVING INTO THE HARD STUFF. LEARN HOW TO:

• CALCULATE THE REGRESSION EQUATION

- CHECK THE ACCURACY OF YOUR EQUATION WITH THE CORRELATION COEFFICIENT
- PERFORM HYPOTHESIS TESTS AND ANALYSIS OF VARIANCE, AND CALCULATE CONFIDENCE INTERVALS
- MAKE PREDICTIONS USING ODDS RATIOS AND PREDICTION INTERVALS
- VERIFY THE VALIDITY OF YOUR ANALYSIS WITH DIAGNOSTIC CHECKS
- PERFORM CHI-SQUARED TESTS AND F-TESTS TO CHECK THE GOODNESS OF FIT

WHETHER YOU'RE LEARNING REGRESSION ANALYSIS FOR THE FIRST TIME OR HAVE JUST NEVER MANAGED TO GET YOUR HEAD AROUND IT, *THE MANGA GUIDE TO REGRESSION ANALYSIS* MAKES MASTERING THIS TRICKY TECHNIQUE STRAIGHTFORWARD AND FUN.



THE FINEST IN GEEK ENTERTAINMENT™
www.nostarch.com

¥24.95 (¥28.95 CDN)

SHELVE IN: MATH/STATISTICS

ISBN: 978-1-59327-728-4



9 781593 277284

5 2 4 9 5



6 89145 77288 3